



SCOTTISH LAW COMMISSION
(Scot Law Com No 124)

Report on Succession

Laid before Parliament by the Lord Advocate
under section 3(2) of the Law Commissions Act 1965

*Ordered by the House of Commons to be printed
24th January, 1990*

EDINBURGH
HER MAJESTY'S STATIONERY OFFICE
£12.00 net

Scottish Law Commission

Item 7 of our First Programme of Law Reform

Succession

*To: The Right Honourable the Lord Fraser of Carmyllie, QC,
Her Majesty's Advocate*

We have the honour to submit our Report on Succession.

(Signed) C K DAVIDSON, *Chairman*
E M CLIVE
PHILIP N LOVE
GORDON NICHOLSON
W A NIMMO SMITH

KENNETH F BARCLAY, *Secretary*
13 November 1989

The Scottish Law Commission was set up by section 2 of the Law Commissions Act 1965 for the purposes of promoting the reform of the law of Scotland. The Commissioners are:

The Honourable Lord Davidson, *Chairman*,
Dr E M Clive,
Professor P N Love, CBE,
Sheriff C G B Nicholson, QC,
Mr W A Nimmo Smith, QC.

The Secretary of the Commission is Mr K F Barclay. Its offices are at 140 Causeway-side, Edinburgh EH9 1PR.



Contents

| <i>Page</i> | <i>Paragraph</i> | |
|-------------|------------------|---|
| | | PART I INTRODUCTION |
| 1 | 1.1 | Background to report |
| 1 | 1.4 | Scope of report |
| | | PART II INTESTATE SUCCESSION |
| 2 | 2.1 | Introduction |
| 2 | 2.3 | Spouse but no issue |
| 2 | 2.4 | Issue but no spouse |
| 3 | 2.5 | Spouse and issue |
| 7 | 2.18 | Deceased survived by neither spouse nor issue |
| 7 | 2.18 | Parents and brothers or sisters |
| 8 | 2.21 | Collaterals of the half-blood |
| 9 | 2.24 | Distribution to heirs as individuals or as members of a family line |
| 13 | 2.28 | Succession by remote relatives |
| 13 | 2.29 | Order of succession |
| 13 | 2.30 | Cohabitants |
| | | PART III LEGAL SHARES |
| 15 | 3.1 | Introduction |
| 15 | 3.3 | Legal shares or discretionary provision |
| 20 | 3.15 | No distinction between heritage and moveables |
| 21 | 3.17 | Estate subject to legal share |
| 21 | 3.18 | Amount of legal share |
| 21 | 3.18 | Surviving spouse |
| 22 | 3.23 | Issue but no spouse |
| 23 | 3.24 | Issue and spouse |
| 24 | 3.28 | Interest |
| 24 | 3.29 | Recommendations |
| 24 | 3.30 | Claiming legal share |
| 26 | 3.31 | Renouncing legal share |
| 27 | 3.34 | Collation |
| 29 | 3.38 | Incidence of legal shares |
| 30 | 3.39 | Agricultural property |
| 32 | 3.45 | Effect of claiming legal share |
| 36 | 3.49 | Anti-avoidance provisions |
| | | PART IV TESTATE SUCCESSION |
| 39 | 4.1 | Validation of certain wills |
| 39 | 4.1 | The problem |
| 40 | 4.2 | A partial solution |
| 40 | 4.3 | A dispensing power? |
| 41 | 4.7 | Case for a dispensing power |
| 41 | 4.8 | Case against a dispensing power |
| 42 | 4.11 | Consultation |
| 42 | 4.12 | Conclusions |
| 46 | 4.20 | Recommendations |
| 46 | 4.21 | Rectification of wills |
| 46 | 4.21 | The problem |
| 47 | 4.22 | Our provisional proposals |
| 47 | 4.23 | Consultation |
| 48 | 4.25 | Conclusions |
| 48 | 4.28 | Recommendations |

| <i>Page</i> | <i>Paragraph</i> | |
|-------------|------------------|--|
| 49 | 4.29 | Effect of marriage |
| 49 | 4.29 | Present law |
| 49 | 4.30 | The case for revocation by marriage |
| 49 | 4.31 | The case against revocation by marriage |
| 49 | 4.32 | Consultation |
| 49 | 4.33 | Conclusion |
| 49 | 4.34 | Effect of divorce and nullity |
| 49 | 4.34 | Present law |
| 50 | 4.35 | The case for revocation by divorce |
| 50 | 4.36 | The case against revocation by divorce |
| 50 | 4.37 | Consultation |
| 50 | 4.38 | Nullity of marriage |
| 50 | 4.39 | Conclusion |
| 51 | 4.40 | Special destinations |
| 53 | 4.43 | Effect of remarriage |
| 53 | 4.44 | Foreign divorces or annulments |
| 53 | 4.45 | Recommendations |
| 53 | 4.46 | Effect of birth of child |
| 53 | 4.46 | Present law: <i>conditio si testator</i> |
| 54 | 4.48 | Consultation |
| 54 | 4.49 | Recommendation |
| 54 | 4.50 | Legatee predeceasing leaving issue |
| 54 | 4.50 | Present law: <i>conditio si institutus</i> |
| 55 | 4.52 | Case for allowing issue to take |
| 55 | 4.53 | Case against allowing issue to take |
| 55 | 4.54 | Consultation |
| 55 | 4.55 | Conclusion |
| 55 | 4.56 | Scope of the rule |
| 58 | 4.65 | Recommendations |
| 58 | 4.67 | Revival of revoked wills |
| 58 | 4.67 | Present law |
| 58 | 4.68 | Criticism of present law |
| 59 | 4.70 | Comparative law |
| 60 | 4.74 | Consultation |
| 61 | 4.75 | Recommendations |
| 61 | 4.77 | Conditional revocation |
| 61 | 4.78 | Making a will for an <i>incapax</i> |
| 62 | 4.81 | Meaning of "heirs" in private documents |
| 63 | 4.84 | Mutual wills |

PART V SURVIVORSHIP

| | | |
|----|-----|--|
| 64 | 5.1 | Present law |
| 64 | 5.2 | Survival for a specified period |
| 65 | 5.5 | Presumptions of survival |
| 66 | 5.6 | Property passing directly from someone else to survivor or first to die of two or more persons |
| 67 | 5.7 | Application of new rules |

PART VI SPECIAL DESTINATIONS

| | | |
|----|------|-------------------------------------|
| 68 | 6.1 | Introduction |
| 68 | 6.2 | Destinations in titles to property |
| 70 | 6.7 | Deemed destinations |
| 70 | 6.8 | Destinations in wills and trusts |
| 71 | 6.10 | Definition of a special destination |
| 73 | 6.15 | Rights of creditors |
| 74 | 6.18 | Evacuation of special destinations |

| <i>Page</i> | <i>Paragraph</i> | |
|---|--|--|
| 75 | 6.23 | Special destinations in leases and assignments of leases |
| 75 | 6.24 | Continued competence |
| 76 | 6.27 | Evacuation |
| 77 | 6.28 | Rights of creditors |
| PART VII DISQUALIFICATION OF CERTAIN HEIRS | | |
| 78 | 7.1 | Introduction |
| 78 | 7.2 | The unlawful killer |
| 78 | 7.2 | Forfeiture |
| 81 | 7.15 | Effect of forfeiture |
| 83 | 7.21 | Relief from forfeiture |
| 85 | 7.28 | The separated spouse |
| PART VIII EXECUTRY QUESTIONS | | |
| 88 | 8.1 | Introduction |
| 88 | 8.2 | Spouse's right to acquire home and furnishings |
| 90 | 8.9 | Time limits on spouse's option to acquire |
| 90 | 8.10 | Valuation of items |
| 90 | 8.12 | Procedure |
| 91 | 8.15 | Protection of trustees and executors |
| 93 | 8.19 | Protection of acquirers of executry assets |
| 94 | 8.21 | Using the will as a link in title |
| 95 | 8.23 | Appointment of executors-dative |
| 96 | 8.28 | Power to issue confirmation where no estate in Scotland |
| 97 | 8.29 | Partial confirmation |
| 97 | 8.32 | Requirement on executors to find caution |
| 100 | 8.40 | Transfer of lease by executor |
| 102 | 8.48 | Transfer in satisfaction of claim |
| PART IX MISCELLANEOUS | | |
| 103 | 9.1 | Adopted children |
| 104 | 9.3 | Mournings |
| 105 | 9.4 | Aliment <i>jure representationis</i> |
| 105 | 9.6 | Temporary aliment out of estate of deceased person |
| 106 | 9.11 | Deathbed |
| 107 | 9.12 | Donations <i>mortis causa</i> |
| 108 | 9.17 | Vesting of fee on forfeiture or renunciation of liferent |
| 109 | 9.18 | Inheritance tax |
| 111 | 9.23 | Definition of "estate" and related terms |
| 113 | 9.27 | Valuation of the estate |
| 114 | 9.28 | Transitional provisions |
| 115 | 9.32 | References to legal rights in existing documents |
| PART X PRIVATE INTERNATIONAL LAW | | |
| 116 | 10.1 | Introduction |
| 116 | 10.3 | Formal validity of wills |
| 116 | 10.4 | Capacity to make and revoke a will |
| 117 | 10.5 | Rights of survivor where property in joint names |
| 119 | 10.10 | The Crown's right as <i>ultimus haeres</i> |
| 120 | PART XI CONSEQUENTIAL AMENDMENTS | |
| 121 | PART XII SUMMARY OF RECOMMENDATIONS | |
| APPENDIX A | | |
| 133 | Draft Succession (Scotland) Bill | |
| APPENDIX B | | |
| 204 | List of those submitting comments | |

Part I Introduction

Background to report

1.1 This report follows on three consultative memoranda on succession law which we published in 1986.¹ These memoranda made a number of provisional proposals for reform of the law of succession and sought views. The response has been most helpful and we are grateful to all of those who took the time to submit comments.² We also published a shorter pamphlet on some of the major issues under consideration. This was widely distributed in public libraries and citizens' advice bureaux throughout Scotland and brought in a number of replies. We held public meetings in Edinburgh, Glasgow and Dundee to publicise, and seek views on, our proposals.

1.2 In preparing the memoranda we had the benefit of a survey on "Family Property in Scotland" carried out for us in 1979 ("the 1979 survey").³ This contained useful information not only on the types and amounts of property held by people but also on public opinion on certain succession issues. We also had the benefit of a public opinion survey on "Attitudes towards Succession Law in Scotland" carried out for us in 1986 ("the 1986 survey").⁴ Since the memoranda were published some further empirical research using information available from the inventories of estates submitted for confirmation of executors has been carried out for us by the Central Research Unit at the Scottish Office.⁵

1.3 In preparing the memoranda we examined the succession laws of many other countries and we referred extensively to some of these laws in developing our proposals for reform. In this report our main concern is to present, reasonably succinctly, our recommendations for reform. We do not therefore repeat all the background information which is in the memoranda.

Scope of report

1.4 The report deals with everything considered in the three memoranda and with some additional suggestions for minor reforms made on consultation. It recommends a complete recasting of the law on intestate succession and legal rights and certain specific changes in relation to testate succession, executries and other matters. We hope to publish, at a later stage, discussion papers dealing with other executry matters and the transmission of debts on death.

1. Consultative Memoranda No 69 on *Intestate Succession and Legal Rights*; No 70 on *The Making and Revocation of Wills*; and No 71 on *Some Miscellaneous Topics in the Law of Succession*. These are referred to in this report as "memorandum 69", "memorandum 70" and "memorandum 71" respectively. The report is published under Item 7 of our Second Programme of Law Reform (Scot Law Com No 8, 1968).

2. A list of those submitting comments appears in Appendix B. At a late stage in the preparation of this report we sought the advice of various consultees, including the Law Society of Scotland, the Scottish Landowners' Federation, the Inland Revenue and Register House, on a number of questions which had arisen. We are very grateful for the assistance received.

3. Manners and Rauta, *Family Property in Scotland* (OPCS, 1981).

4. The results of this survey, carried out by System Three Scotland, are published in Appendix II to memorandum 69.

5. Central Research Unit, *Succession Law: A report to the Scottish Law Commission about estates passing on death in Scotland* (1989) ("the CRU report"). See also M. Munro, "Housing Wealth and Inheritance", *Journal of Social Policy* (1988), 17, 417.

Part II Intestate Succession

Introduction

2.1 The law on intestate succession applies in a large number of cases. In a sample of estates where confirmation was obtained in 1986/87 about a third of the estates were intestate.¹ This proportion was higher (almost a half) in the case of small estates.² There are many deaths in Scotland which are not followed by the confirmation of an executor, because the estate is of a size or nature which makes this unnecessary.³ Yet in many of these cases there will be small items of moveable property to be distributed in accordance with the rules on intestate succession.

2.2 The rules on intestate succession have, of necessity, to be general. They cannot cater for every type of family situation in the way individual testators can. It is more important, in our view, that they should be suitable for small and medium sized estates than that they should be suitable for very large estates.⁴

Spouse but no issue

2.3 Under the present law, where there are no issue (ie descendants) of the deceased, the surviving spouse may, depending on the amount and nature of the intestate estate, have to share the estate with the deceased's brothers and sisters or parents.⁵ In memorandum 69 we pointed out that this did not seem to be in accordance with public opinion,⁶ and asked whether the whole estate should go to the surviving spouse or whether the brothers or sisters or parents should share in estates over a certain value. Most of those who submitted comments thought that the estate should go entirely to the surviving spouse. This is certainly the simplest solution. It is in line with public opinion and with what most married testators would probably provide.⁷ We therefore recommend that:

- 1. Where a person dies intestate survived by a spouse but no issue the spouse should inherit the whole intestate estate.**

(Clause 1(2))

Issue but no spouse

2.4 Under the present law where a deceased dies intestate survived by issue (eg children, grandchildren or great-grandchildren) but not by a husband or wife, the

1. CRU report para 3.5.

2. Small estates were defined, at the time of the sample, as those under £13,000.

3. See memorandum 69, para 1.16.

4. The CRU research (based on confirmations obtained in 1986/87) found that 83% of all the estates in the sample had a gross value of no more than £60,000. The majority (62%) of intestate estates had a gross value of no more than £20,000. The ratio of testate to intestate estates increased with the value of the estate, being 5:1 in the case of estates over £60,000. CRU report paras 4.14 to 4.15.

5. See memorandum 69, paras 2.7 and 3.24 to 3.32. Where the bulk of the estate consists of business assets it is quite possible for the deceased's brother to inherit well over half the estate.

6. In the 1979 survey 89% of informants thought that the widow should entirely exclude the brother (Table 4.7). In the 1986 survey 62% thought that the widow should entirely exclude parents in the case where the deceased was "neither poor nor wealthy". Where he was "very poor" the figure was 73% and where he was "very wealthy" it was 48%, although even in this last case a further 32% thought the estate should go mainly to the widow. (Memorandum 69, p229).

7. The CRU survey found that 79% of married testators left their entire estate to their spouse. A further 10% left nearly all their estate to their spouse, with only minor bequests to others. In most of the remaining cases some or all of the estate was left to children. CRU report paras 5.3 to 5.6.

issue take the whole estate. On consultation there was virtually no dissent from the proposition that this should continue to be the law. We therefore recommend that:

2. **Where a person dies intestate survived by issue but not by a spouse, the issue should (as under the existing law) inherit the whole intestate estate.**

(Clauses 1 and 2)

Spouse and issue

2.5 The present law provides a very complicated answer to the simple question of how a person's estate should be divided when he or she dies intestate survived by a spouse and issue. It involves three types of prior rights for the spouse (house, furniture and a financial sum), legal rights (*jus relictii*, *jus relictiae* and legitim) for the spouse and issue in moveable property only, and intestate succession rights in the rest for the issue, but not the spouse. Not only is this needlessly complicated but it also produces very different results depending on whether the deceased's estate is largely heritable or largely moveable, and on the extent to which it consists of property subject to the surviving spouse's prior rights. In the case of a fairly large estate, for example, the bulk of it may go to the surviving spouse, or to the issue, depending on whether the deceased owned a house, whether the surviving spouse was ordinarily resident in it at the date of the deceased's death, and how the purchase of the house was financed.¹ The arbitrary results reached under the present law are due mainly to the fact that the surviving spouse's prior rights are expressed in terms of rights in specific assets (notably the house). Some inconsistency is also caused by the fact that legal rights are exigible only out of moveables.

2.6 On consultation there was general agreement on the need for reform. The defects in the present law were clearly recognised. In memorandum 69 we put forward a number of options for reform. None of them made use of legal rights (which are an unnecessary complication in the division of intestate estate). One option was to allocate the whole intestate estate to the surviving spouse. This has a number of advantages, not the least being its simplicity, but the Scottish public opinion surveys suggested that most people would expect the issue to share in a very large estate.² This view was confirmed on consultation.

The options which attracted most support on consultation were to give the surviving spouse either

- (a) a fixed sum (or the whole estate, if less) plus half the excess, or
- (b) decreasing proportions of "slices" of the whole estate.

The way in which these systems would work would depend on the amounts of the fixed sum and various slices. The policy of the present law is to ensure that the surviving spouse can retain the family home and furniture (up to specified financial limits) plus a capital sum. Under the present law the prior rights of the surviving spouse can absorb up to £98,000 of an intestate estate in a case where the deceased is also survived by issue.³ If the policy of the present law is to be maintained, as we think it should be, then the fixed sum, or first slice, would have to be set at a fairly high level (say, £100,000). This would mean that any differences between the two systems would be confined to very large estates. For the sake of illustration let us compare systems where the surviving spouse receives (a) a fixed sum of £100,000 plus half the excess or (b) 100% of the first £100,000, 80% of the next £50,000, 70% of the next £50,000, 60% of the next £50,000, and 50% of the rest. In each case the issue would take what was left. On these figures the systems would operate as follows.

1. See memorandum 69, para 2.2.

2. In the 1986 survey 51% thought the estate should go entirely to the widow if the deceased was "neither poor nor wealthy". The figure was 65% where he was "very poor" and 38% where he was "very wealthy". Memorandum 69, p227.

3. House up to £65,000, furniture and effects up to £12,000, and a cash sum of £21,000. Succession (Scotland) Act 1964, ss8 and 9 as amended by SI 1988, No 633.

| Amount of estate | Fixed sum plus half excess | | Slice system | |
|------------------|----------------------------|---------|--------------|--------|
| | Spouse | Issue | Spouse | Issue |
| £100,000 or less | All | — | All | — |
| 150,000 | 125,000 | 25,000 | 140,000 | 10,000 |
| 200,000 | 150,000 | 50,000 | 175,000 | 25,000 |
| 300,000 | 200,000 | 100,000 | 230,000 | 70,000 |

The first point to be made—and it cannot be made too strongly—is that for most intestate estates the “fixed sum plus half the excess” system and the “slice” system would have exactly the same result. The whole estate would go to the surviving spouse. In the case of estates over £100,000 the “slice” system would, on these figures, give less to the issue than the “fixed sum plus half the excess” system. Of course, it would be possible to set the first slice at a lower level and so bring the issue in earlier but this would conflict with the policy of ensuring that the surviving spouse receives enough to cover the value of the home and furniture. Given this restraint, which we think is a realistic one, we can see no real advantage in the slice system. The great disadvantage of the slice system is that it is more complicated and difficult to remember and apply. For this reason several consultees were strongly opposed to it. It is, we think, important that the law on intestate succession should be as simple and easily understood as possible. We have therefore come down in favour of the “fixed sum plus half the excess” system.

2.7 So far as the amount of the fixed sum is concerned, we have already mentioned that under the present law a spouse, in favourable circumstances, may receive prior rights worth £98,000 where the deceased is also survived by issue. Given that property values have increased since the present limits were fixed, we consider that a fixed sum of £100,000 would preserve the surviving spouse’s position and ensure that in most cases of intestacy he or she would be able to retain the matrimonial home and furniture. The Secretary of State should be empowered to alter this figure from time to time by statutory instrument.¹ We therefore recommend that:

3.(a) Where a person dies intestate survived by a spouse and issue, the spouse should have a right to £100,000 or the whole intestate estate if less. Any excess over £100,000 should be divided equally, half to the spouse and half to the issue.

(b) The Secretary of State should be given power to alter the figure of £100,000 from time to time by statutory instrument.

(Clause 1)

2.8 If the deceased died partially testate leaving a spouse and issue then normally the above rule would simply apply to the intestate estate.² If, for example, a man left a legacy of £2,000 to a charity with which he had been connected but otherwise died intestate then the rules in recommendation 3 would simply apply to the intestate estate. Similarly if the deceased had left a legacy of £1,000 to one of his children then the above rules would simply apply to the intestate estate. If the intestate estate were under £100,000 the spouse would inherit it all. If it were over that amount the child would receive his or her share of the intestate estate in addition to the legacy. A problem does arise, however, if the spouse is given a legacy. The question is whether the legacy should be deducted from the fixed sum. The result of doing this is that the spouse derives no benefit from the legacy. On the other hand if the legacy is not deducted from the spouse’s statutory fixed sum the result is simply that the rules of intestate succession apply to the intestate

1. See Succession (Scotland) Act 1964, ss8 and 9, as amended by the Succession (Scotland) Act 1973.

At present the power is restricted to increases. Circumstances can be envisaged, however, where a power to decrease would be equally essential in order to preserve the real effect of the statute.

2. In some cases (eg where the deceased left most of his estate to a charity) it would be to the advantage of the surviving spouse and issue to claim legal share instead of their rights on intestacy. See Part III below. We recommend later that anyone claiming their legal share should forfeit all other rights of succession to the deceased. See para 3.45 below.

estate and the rules of testate succession apply to the testate estate. In the case of estates over £100,000, the spouse will benefit under both sets of rules. This, however, is not necessarily objectionable. Indeed there is much to be said on grounds of principle and simplicity for allowing the ordinary rules to apply. The average testator would probably expect legatees to receive their legacies and the normal rules of intestate succession to govern his intestate estate. In memorandum 69 we put forward both options for consideration¹ and both attracted some support. In this situation we think that the ordinary rules of testate and intestate succession should apply and that there should be no special exception to prevent a surviving spouse from taking under both.

2.9 In memorandum 69 we also asked whether the surviving spouse should be given an option to require the deceased's interest in the matrimonial home and household goods to be allocated to him or her in satisfaction or part satisfaction of his or her rights on intestacy. This was widely supported on consultation and we think this option should be available. We consider, however, that it should be available not only on intestacy but also in certain cases of partial intestacy or testacy where the spouse is not already bequeathed the house and contents. As this would be a general option, affecting the position of executors in relation to the surviving spouse in all cases, we deal with it later in Part VIII of this report.

2.10 Where the deceased is survived by a spouse who is the parent of all his children there is a strong possibility that the children will eventually inherit from the surviving spouse. This is less likely if the surviving spouse is a second or subsequent spouse who is not the parent of the deceased's children. The deceased's children may well feel more resentment about his estate passing to someone whom he may have married just a year or so before his death than about it passing to their own mother. The same sort of situation could arise if the deceased had children by someone to whom he or she was not married and then married someone else. The question therefore arises whether there should be any special rule for the case where the deceased is survived by a spouse and children but the spouse is not the parent of all the children.

2.11 The 1986 public opinion survey showed that there is significantly less support for giving the whole estate to the surviving spouse, where he or she is a second spouse and the deceased is also survived by children of an earlier marriage.² Whereas 51% of respondents would have given the whole of an average sized estate to the first spouse, in preference to two grown-up children, only 19% would have given it to the second spouse. Correspondingly, the proportion opting to divide the estate half and half between spouse and children increased from 19% in the case of the first spouse to 39% in the case of the second spouse. Interestingly, however, 85% thought the second spouse should receive at least half of the estate, and this figure remained the same even where the hypothetical deceased was very poor or very wealthy. In short, the shift in public opinion in the case of the second spouse appears to be a shift towards giving the children half of the estate rather than allocating it all to the spouse.

2.12 Some legal systems distinguish the case of the surviving spouse who is also the parent of all the deceased's surviving children from the case of the surviving spouse who is not. The Uniform Probate Code, for example, provides that the intestate share of the surviving spouse is:

- “(3) if there are surviving issue all of whom are issue of the surviving spouse also, the first [\$50,000], plus one-half of the balance of the intestate estate;
- (4) if there are surviving issue one or more of whom are not issue of the surviving spouse, one-half of the intestate estate”.³

1. Paras 3.19 to 3.20.

2. See memorandum 69, pp227-228.

3. S2-102.

The Manitoba Law Reform Commission has recommended that the surviving spouse should have a reduced fixed sum (\$50,000 instead of \$100,000) where one or more of the deceased's issue are not also issue of the surviving spouse.¹

2.13 One unfortunate feature of the Uniform Probate Code's solution is that it could cause hardship to the second spouse, who will often receive half, instead of the whole, of a small or modest estate. Another unfortunate feature of the solution is that it confers an unnecessary benefit on the children of the second marriage, merely because of the existence of a child of an earlier marriage or a child of a non-marital or extra-marital relationship. The same criticisms apply, but with less force, to the suggested Manitoba solution.

2.14 In memorandum 69 we mentioned another option which would have involved treating the issue of each marriage separately and giving the surviving spouse a proportionate share of his or her fixed sum in relation to his or her own children by the deceased and no fixed sum in relation to the deceased's other children.² This option, which was rather complicated, attracted little support on consultation and we do not pursue it further.

2.15 The main difficulty in relation to the surviving spouse who is not also the parent of all the deceased's children is, as we pointed out in memorandum 69, that there are many different ways in which this situation can arise. The same rule is not necessarily appropriate in all cases. Here are some examples.

- (1) A man's wife dies intestate after 40 years of marriage. There are two grown-up children of the marriage. The whole of the wife's estate passes to the husband by virtue of prior rights. A year later he marries again. A month after that he dies leaving an estate worth about £70,000 which, under the normal rules, would pass to his wife. This is the type of situation where there is the strongest case for protecting the position of the children.
- (2) A man is divorced by his wife after 40 years of marriage. There are two grown-up children of the marriage. The couple's property, which was all accumulated during the marriage, is divided equally between them at the time of the divorce. The man remarries immediately and dies two years later. Here there is a slightly less strong case for protecting the position of the children. They may still inherit their mother's share of their parents' property.
- (3) A man's wife dies after a year of marriage. There is one child of the marriage. Neither spouse has any significant property at that time. The man remarries a year later and has two children by his second wife. All three children are brought up together and are held in equal affection by the husband and wife. Forty years after his second marriage the man dies intestate. By this time he has accumulated property worth about £30,000. His wife (now in her sixties) has savings of about £1,000 in her name but no other property apart from personal effects. Here there is only a weak case for departing from the normal rule.
- (4) A couple are divorced after seven years of marriage. The wife is awarded sole custody of the two children of the marriage and a small capital sum. Both parties remarry. The husband has two children by his second marriage. He sends alimony for his first two children until they are 16 but has little other contact with them. He is killed in a car crash twenty years after his second marriage. His property consists of the family home (burdened with a loan), furniture, and some life insurance. Again it is by no means obvious that the interests of the children of the first marriage require, or justify, any departure from the normal rules which (let us suppose) would give the whole estate to the second wife.
- (5) After twenty years of marriage a husband has an extra-marital affair as a result of which a child is born. The husband dies twenty years after that.

1. *Report on Intestate Succession* (1985), pp16-20.

2. Para 3.45.

There are two children of the marriage. He leaves an estate of, say, £50,000 consisting mainly of the family home. Again it is by no means obvious that the existence of a child who is not also the child of the surviving spouse justifies any departure from the normal rule.

2.16 The above examples show that the problem is more complicated than it might appear at first sight and that the case for distinguishing between the surviving spouse who is, and the surviving spouse who is not, the parent of all the deceased's children is not always compelling. The Uniform Probate Code's solution would produce satisfactory results in some cases but not in all, and not necessarily in most. Significant variables are the amount of the deceased's estate,¹ the length of the deceased's relationship with the surviving spouse, and the prospects of the children inheriting from the deceased indirectly. In relation to this last variable it is worth bearing in mind that, even where the surviving spouse is the parent of all the deceased's children there is no guarantee that the children will inherit from him or her. A modest estate may well be used up entirely by the surviving spouse. Even if the children do inherit from their surviving parent this may not happen for twenty or thirty years. Conversely, step-children may well inherit from the surviving spouse under a will in their favour.

2.17 In memorandum 69 we left this difficult question open and, having set out the arguments, invited views. A majority of those representative bodies and institutions who commented favoured treating the surviving spouse in the same way whether or not he or she was the parent of all the deceased's children. The individual respondents were almost equally divided. In this situation we have decided not to recommend any special rule for the case where the surviving spouse is not the parent of all the deceased's children.

Deceased survived by neither spouse nor issue

Parents and brothers or sisters

2.18 Under the present law, if the deceased is not survived by issue but is survived by either or both of his parents and is also survived by brothers or sisters, the surviving parent or parents take one half of his intestate estate and the surviving brothers and sisters the other half.² In English law—and the same appears to be true for most other jurisdictions in the English speaking world—the parents take to the exclusion of brothers or sisters.³ Other solutions are possible,⁴ but the main choice seems to us to be between the two just mentioned. In favour of preferring parents to brothers or sisters it can be argued that the links between a parent and an unmarried child are, in general, likely to be closer than the links between brothers and sisters. The parents are likely to have contributed more to the deceased's welfare and to have a stronger moral claim to succeed. If the parents are young, and the brothers and sisters still children, it would seem more appropriate and convenient that the whole estate should pass to the parents. If the parents are old, and the brothers and sisters adult, the parents may well be in greater need. Many intestate estates are very small, and this seems particularly likely to be the case where the deceased dies young and unmarried. In this kind of case fragmentation between parents and brothers or sisters seems undesirable. On the other hand it can be argued that there is no point in passing property to elderly parents only to have it pass a few years later to the brothers or sisters when the parents die. There are arguments both ways.

2.19 So far as Scottish public opinion is concerned there appears to be a preference for the parents, rather than a brother, as the sole or main beneficiary but also support for some sharing between parents and brother. In the case of an estate of average size, for example, 41% of respondents in the 1986 survey would have given the whole estate to the parents, 24% would have given it mainly to the parents and only 30%

1. Most intestate estates are of modest amount. See CRU report, para 4.15.

2. Succession (Scotland) Act 1964, s2(1). The issue of a deceased brother or sister represent their parent under s5 of the Act.

3. The English rule is in the Administration of Estates Act 1925, s46.

4. See memorandum 69, para 3.49, note 46.

would have preferred the half and half solution of the present law. In the case where the deceased was very wealthy the figures were 29%, 27% and 37% respectively.¹ It would be possible to devise a rule which would give the parents, in competition with a brother or sister of the deceased, the whole of a small estate and diminishing proportions of larger estates. It may be doubted, however, whether the results would justify the added complexity in the law.

2.20 In memorandum 69 we invited views on the questions whether the estate should go to the parents, or to the brothers and sisters, or should be shared between parents and brothers and sisters, either half and half as under the present law or in some other way. All of the institutional consultees were in favour of retaining an equal division between parents and brothers and sisters and so were the majority of individual respondents. In these circumstances, and as the arguments for a change in the law are not conclusive, we recommend no change in the present rule.

Collaterals of the half-blood

2.21 Under Scots law if a person dies intestate without being survived by a spouse, issue or parents but survived by a brother and a half-brother, the brother takes the whole estate to the exclusion of the half-brother. However, if the deceased is survived only by half-brothers they take the whole estate.² The effect of the rules on representation is that the half-brother will be excluded also by issue of a predeceasing brother of the deceased.³ The increased number of divorces and remarriages and births out of wedlock makes this matter of greater importance than it used to be and makes it necessary to reconsider the existing rule. The main options are as follows.

- (a) Collaterals of the full-blood exclude collaterals of the half-blood.
- (b) Collaterals take equally, whether they are of the full-blood or of the half-blood.⁴
- (c) Collaterals are regarded as taking in place of their parents. So if the deceased is survived by a full brother and by a half brother who is the son of the deceased's mother and her second husband, the full brother will take three quarters of the estate ($\frac{1}{2}$ from the deceased's father and $\frac{1}{4}$ from the deceased's mother) and the half-brother one quarter (because he is entitled to nothing in place of the deceased's father).⁵

The last of these solutions appears to be justifiable only if the mother and father are regarded as having been entitled to a half of the deceased's estate each (with no accretion to the survivor) and only if the idea of succession by paternal and maternal lines is applied generally in the law. It would not therefore be appropriate for Scots law unless the law were to be changed in ways which we would not wish to recommend. The realistic choice appears therefore to be between a system where the full-blood excludes the half-blood and a system where collaterals of the full or half-blood take equally. It is impossible to generalise about the family situation of half brothers and sisters. In some cases they will have been brought up together as members of the same family unit. In others they will not. If, however, collaterals of the half-blood are admitted to the list of heirs on intestacy at all, it is hard to see why they should be excluded by collaterals of the full-blood. To exclude them in a case where there has been a close family relationship with the deceased is, we suspect, likely to give rise to a greater feeling of injustice than to include them in a case where there has not been a close family relationship.

2.22 So far as public opinion is concerned the majority view supports equal treatment of collaterals of the full and the half blood. In the 1986 survey respondents were asked how a man's estate should be distributed if he died intestate survived by a sister and a half-sister but no other close relatives. Where the estate was of average size 58% thought it should be divided equally between the sister and the half-sister. Only 15% thought it should go entirely to the sister, while 24% thought it should go mainly to the sister. The general pattern was not very different when the hypothetical

1. See memorandum 69, p230.

2. Succession (Scotland) Act 1964, s3.

3. *Ibid*, s5.

4. This is the rule in New Zealand, in almost all Australian states and in most states of the USA.

5. This is the rule in French law. Code civil, arts 733 and 752.

deceased was very poor or very wealthy. The solution which attracted most support was an equal division between sister and half-sister. The full sister's claims were seen as being strongest where the deceased was very poor but even in this situation only 20% of respondents favoured the present policy of allocating the estate entirely to the full sister.¹

2.23 In memorandum 69 we reached the provisional conclusion that collaterals of the half-blood should inherit equally on intestacy with collaterals of the full-blood.² The institutional consultees were divided on this, but the majority of individual respondents favoured equal treatment. One experienced succession lawyer observed that most people were amazed to learn that the half-blood inherited nothing unless there were no collaterals of the full-blood. Taking into account the results of the public opinion survey and the results of consultation, we recommend that:

4. Collaterals of the half-blood should inherit equally on intestacy with collaterals of the full-blood.

(Clause 1(4))

Distribution to heirs as individuals or as members of a family line

2.24 The present Scottish rules on intestate succession contain elements of distribution to heirs as equally entitled individuals (*per capita*) and distribution to heirs as members of a line of the family (*per stirpes*). The rules are set out in section 6 of the Succession (Scotland) Act 1964 which provides that if the heirs are all in the same degree of relationship they succeed equally as individuals but that in other cases they succeed *per stirpes*, the first division into lines being made at the level of the nearest surviving relatives. This produces, for example, the following results. In all cases it is assumed that the deceased dies intestate without any nearer relative. In the diagrams brackets indicate that the person concerned has predeceased the deceased.

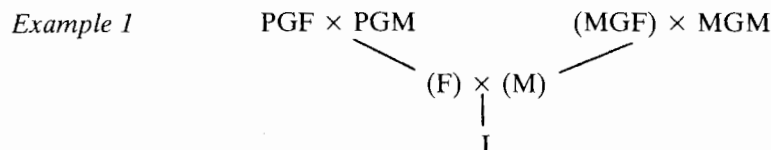

The deceased intestate, I, is survived by both his paternal grandparents, PGF and PGM, but only one maternal grandparent, MGM. Under section 6, the three grandparents succeed equally as individuals and take a third each. In some countries they would succeed as members of the paternal or maternal lines, the paternal grandparents taking half between them and the maternal grandparent the other half.

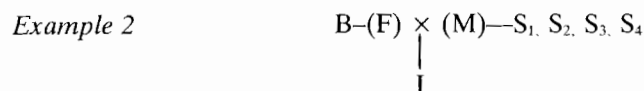

The intestate, I, is survived by his father's brother, B, and his mother's four sisters. Again, under section 6, the uncle and aunts, being equally closely related, succeed equally as individuals and take a fifth of the estate each. Under a system of succession by family lines the father's brother, as the only member of the paternal line, would take half and the mother's sisters, as members of the maternal line, would share the other half equally between them.

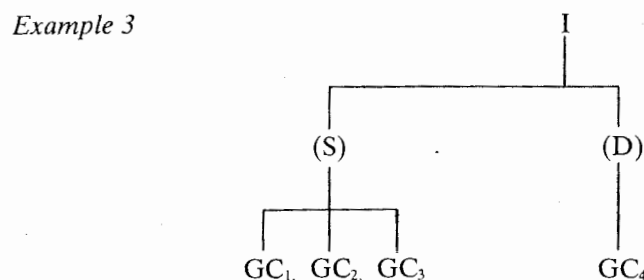

The intestate, I, is survived by four grandchildren, three of them the children of

1. See memorandum 69, p231.
2. Para 3.52.

his predeceasing son (S) and one of them the child of his predeceasing daughter, (D). Under section 6, the four grandchildren, being equally near in relationship to the deceased, take a quarter of his estate each. Under a system of succession by family lines the son's children would take his half of the estate equally between them (ie a sixth of the whole estate to each) and the daughter's child would take the other half.

Example 4

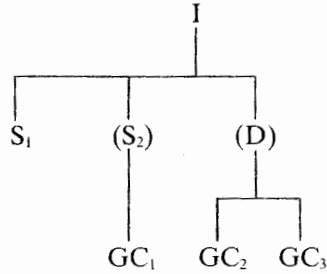

The intestate, I, is survived by a son, S₁, a grandchild who is the issue of a predeceasing son (S₂), and two grandchildren who are the issue of a predeceasing daughter (D). Here the deceased's heirs are not all in the same degree of relationship to him and so, under section 6, distribution is *per stirpes*. The son takes a third: the child of the predeceasing son takes the third his father would have taken: and the two children of the predeceasing daughter share the third their mother would have taken and therefore take a sixth of the whole estate each.

Example 5

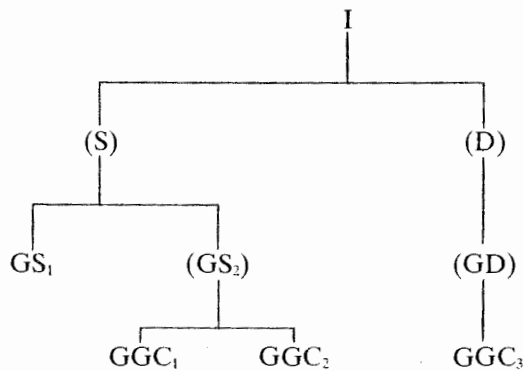

The intestate, I, is survived by a grandson, GS₁, and three great-grandchildren. Two of the great-grandchildren are the sons of a predeceasing grandson (GS₂) and the third is the son of a predeceasing granddaughter (GD). Here, under section 6, the estate is first divided into three (there being no surviving children of the deceased). The surviving grandson takes one third. The sons of the predeceasing grandson share his third equally between them. And the son of the predeceasing granddaughter takes the third which would have gone to his mother had she survived.

The argument for an equal division among those who are in the same degree of relationship to the deceased is that people nowadays are more likely to regard close relatives as individuals rather than as representatives of a family line and are likely to wish them to share equally—"equally near equally dear". Where, for example, only grandchildren survive, an equal division may seem more natural than an unequal division. There is research evidence from the United States suggesting that, where there are no surviving children of the deceased, people there would clearly prefer grandchildren to inherit equally rather than by family lines.¹ We know of no system which has moved from equal treatment of grandchildren to a family line system. On the other hand there have been suggestions in some jurisdictions which have a family line system that it should be changed so as to provide for equal treatment of surviving

1. Follows, Simon, Snapp and Snapp, "An Empirical Study of the Illinois Statutory Estate Plan", 1976 Univ of Illinois Law Forum 717; "A Comparison of Iowans' Dispositive Preferences with selected Provisions of the Iowa and Uniform Probate Codes", 63 Iowa Law Rev 1041 (1976). In the first survey over 95% of informants preferred equal division. In the second, 87% of respondents preferred equal division. The Uniform Probate Code provides, like Scots law, for inheritance in equal shares where only grandchildren survive the deceased, S2-103.

grandchildren.¹ One argument for a family line system is that most wills provide for the issue of predeceasing children to succeed in this way.² However, this type of provision in a will is aimed primarily at the common situation where at least one child survives the testator. It is not clear that testators generally address their minds to the less common situation which would arise if *all* of their children predeceased them and they were survived *only* by grandchildren. Another argument for a family line system is that less depends on the date when, say, a child of the deceased dies. Under the existing Scottish rule a deceased's estate will be divided by family lines if the deceased is survived by one child and the children of two predeceasing children, even if the sole surviving child dies a week or so after the deceased, but would be shared equally among the grandchildren if that child had died, say, a week before the deceased. However, throughout the law of succession much depends on the order of death and we do not regard this type of result as a serious anomaly. Even under a family line system much may depend on the order of deaths.

2.25 In memorandum 69 we expressed the provisional view that there was no need to change the present rule whereby when grandparents (or their brothers or sisters) succeed to an intestate estate they take equally as individuals, without regard to whether they are from the father's or the mother's side of the family.³ This was supported by all those who commented on it. There was also unanimous support for our provisional view⁴ that there was no need to change the present rule whereby uncles and aunts succeed equally as individuals, without regard to whether they are from the father's or the mother's side of the family. There was nearly unanimous support for our provisional view that where only grandchildren survive they should inherit equally as individuals.⁵ In all of these respects we recommend no change in the existing law.

2.26 We pointed out in memorandum 69 that it would be possible to take further the idea that grandchildren should inherit equally by adopting a system of equal division at each generation even if a member of a previous generation survived.⁶ This system, which has been advocated in the United States of America,⁷ can be illustrated by the following example.

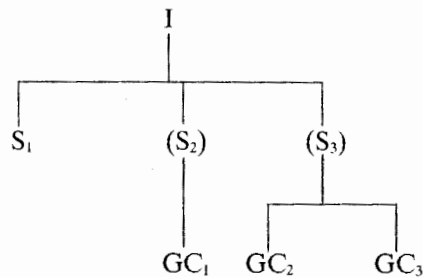

The intestate, I, is survived by a son, S₁, and by three grandchildren, one of them the issue of a predeceasing son and two of them the issue of another predeceasing son. Under a system of equal division at each generation, the son, S₁, would take a third of the intestate estate and the three grandchildren would share the other two thirds equally, taking 2/9ths of the estate each. The argument for this approach is that, if it is right that a grandparent is likely to hold his or her grandchildren in equal affection, this must apply whether or not a child survives. The approach ensures that heirs of the same generation are treated equally. On the other hand the system is slightly complicated and is perhaps not the solution which would occur to the average testator. We reached no provisional conclusion on this question in memorandum 69, but merely invited views.⁸ There was a division of opinion among those who

1. See articles cited in preceding footnote.

2. CRU report, para 5.9.

3. Para 3.54.

4. Para 3.53.

5. Para 3.56. The Law Society of Scotland, however, favoured a *per stirpes* rule.

6. Para 3.57.

7. See Waggoner, "A Proposed Alternative to the Uniform Probate Code's System for Intestate Distribution among Descendants", 66 *Northwestern Univ Law Rev* 626 (1971).

8. Para 3.57.

commented, some favouring the existing Scottish system and some favouring the system of equal division among heirs of the same generation. Given that there are conflicting views and arguments on this question, and that there is no great demand for change, we have concluded that we should not recommend the introduction of a system of equal division among heirs of the same generation.

2.27 The Succession (Scotland) Act 1964 refers, in relation to cases where the heirs are not all in the same degree, to succession *per stirpes*. We think that this Latin term is inappropriate and unhelpful in a modern statute. Translated, it means by stocks, or stems or lineages,¹ but even this is not very helpful. In fact, "*per stirpes*" is a shorthand legal expression for a system of succession of which the essential features, in the case of descending lines, are as follows.

- (a) There are as many lines (or stocks, or stems) descending from a deceased person at the relevant date² as there are children of his who survive that date or who have predeceased that date leaving issue who survive it.
- (b) A member of any line who survives the relevant date excludes his own descendants from the succession.
- (c) If a member of any line has predeceased the relevant date leaving issue who survive that date, the issue take the share the predeceaser would have taken had he survived.
- (d) Subject to these rules the estate, or the portion or share of it in question, is divided equally between or among the family lines entitled to it.

We think that it would be helpful to the user of the legislation to dispense with the term *per stirpes*, and to set out in plain English the way in which intestate estate is to be divided in the different situations which may arise. This is the approach taken in the draft Bill.³ The following example illustrates how it works.

Example

The deceased dies intestate on a date ("the relevant date") after the new Act comes into force, survived by an uncle and the issue of two uncles who have predeceased that date leaving issue who have survived it. The issue descended from the uncles are as shown below. A vertical line between two people indicates the relationship of parent and child. Brackets indicate that the person bracketed has predeceased the relevant date.

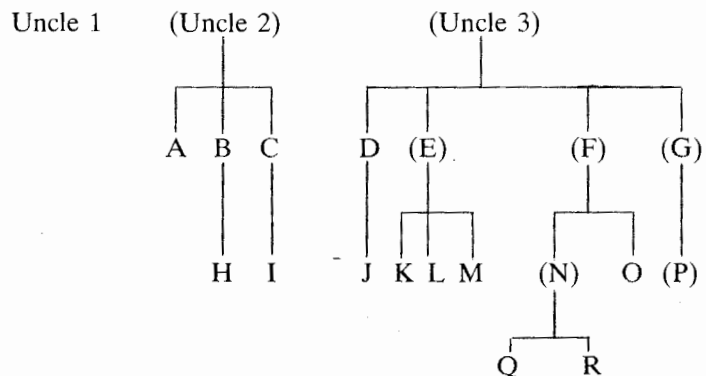

The first step is to apply clause 3(1) of the Bill, which provides for the intestate's estate to be divided into three portions, one of which goes to Uncle 1, one to the issue of Uncle 2 and one to the issue of Uncle 3.

The next step is to apply clause 3(2) to Uncle 2's portion. This results in that portion being divided into three equal parts, one of which goes to each of A, B and C.

1. These are three of the translations given in Lewis and Short, *A Latin Dictionary*.
 2. This might not be the date of the person's own death. In applying the system to the share of an intestate's estate passing on his death to the issue of a deceased uncle the relevant date would, for example, be the date of the intestate's death and not the date of the uncle's death.
 3. See clause 3.

Then clause 3(2) is applied to Uncle 3's portion. This results in that portion being divided first into three equal parts. (G's line of the family is ignored because G predeceased the relevant date without leaving any issue who survive that date.) One of the three parts goes to D. One goes to the issue of E equally between them. The remaining part goes to the issue of F in accordance with the same rules. It is first divided into two. One half goes to O and the other half is divided equally between Q and R.

Succession by remote relatives

2.28 Under the existing law in Scotland relatives, however remote, can succeed to a deceased's intestate estate in the absence of any prior relative. A number of other countries exclude remote relatives beyond a certain degree from the list of heirs on intestacy.¹ The reasons for doing so are partly the expense and difficulty of tracing such relatives and partly the fact that they will often have had little or no connection with the deceased. They are, in American parlance, "laughing heirs". In memorandum 69 we invited views on the question whether relatives more remote than grandparents or their issue should be precluded from succeeding on intestacy.² We thought that there might be a fairly widespread reluctance to have property forfeited to the state rather than going to a remote relative. The majority of those who commented were against any restriction on succession by remote relatives and accordingly we make no recommendation that remote relatives should, as such, be excluded automatically from the list of those entitled to succeed on intestacy.

Order of succession

2.29 Except as otherwise stated in the preceding paragraphs we are recommending no changes in the order of succession to intestate estate in Scots law. Accordingly, if our recommendations are implemented, the order of succession in a case where the deceased is survived by neither spouse nor issue would be:

- (1) parents; brothers and sisters
- (2) uncles and aunts
- (3) grandparents
- (4) great-uncles and great-aunts
- (5) great-grandparents
- (6) brothers and sisters of great-grandparents and so on.

If a person would have succeeded (other than as ascendant or spouse) had he survived the intestate but has predeceased leaving issue who survive the intestate then those issue will take by representation. So if a man dies survived by a nephew (the son, say, of a predeceasing sister) and an uncle, the nephew would succeed to the whole intestate estate and (as he comes in place of the deceased's sister) would exclude the uncle. Similarly a first cousin would exclude grandparents and so on.

Cohabitants

2.30 We received suggestions that the law on intestate succession should recognise the claims of someone who had cohabited with the deceased, as husband and wife, for a long time before his death, without being legally married to him. There are undoubtedly cases where a cohabitant in this situation would be unable to establish a marriage by cohabitation with habit and repute but where it would nonetheless be reasonable to suppose that the deceased, if he or she had made a will, would have provided for the cohabitant. In some jurisdictions a long standing cohabitant does have rights of intestate succession.³ In memorandum 69 we recognised that there was a strong case for making some provision for *de facto* spouses but took the view that the best way of recognising the claims of long-standing cohabitants would be by giving them the right to apply for a discretionary provision.⁴ We did not, therefore, consider

1. In England and Wales, for example, relatives more remote than grandparents or their issue do not succeed on intestacy. Administration of Estates Act 1925, ss46 and 47. This is also the solution adopted under the Uniform Probate Code.

2. Para 3.58.

3. Eg South Australia (Family Relations Act 1975, s11(1); Administration and Probate Act 1919-75, s72(h)(2)); New South Wales (Wills, Probate and Administration (De Facto Relationships) Amendment Act 1984 No 159); Slovenia (see Sarcevic, "Cohabitation without Formal Marriage in Yugoslav Law" in Eekelaar and Katz, *Marriage and Cohabitation in Contemporary Societies* (1979) pp293-298).

4. Paras 4.86, 4.87 and 4.94.

whether they should be given automatic rights of intestate succession and did not ask consultees to comment on this. For reasons given later in this report¹ we have decided not to recommend the introduction of a system of discretionary provision. This places the question whether cohabitants should be recognised as entitled to succeed on intestacy back on the agenda. It is a difficult and potentially controversial question on which we would wish to consult fully before making recommendations. We intend to initiate the process of consultation in a discussion paper on family law which is currently being prepared.

1. Paras 3.4 to 3.7, 3.9, 3.13 and 3.14.

Part III Legal Shares

Introduction

3.1 In this part of the report we make recommendations for reform of the law relating to the legal rights of the surviving spouse and issue. Under the existing law the surviving spouse has a legal right (*jus relictae* or *jus relictii*)¹ to a third of the deceased's moveable estate² if there are issue of the deceased surviving or to a half of the moveable estate if there are no issue surviving. The children of the deceased have a legal right (*legitim*) to a third of the deceased's moveable estate if there is a surviving spouse or a half if there is no surviving spouse. If a child has predeceased the deceased leaving issue, the issue are entitled to the share of *legitim* the child would have taken had he survived.³ Legal rights are a restriction on testamentary freedom and a protection against disinheritance. Even if a testator in his will leaves all his estate to, say, a friend or a charity, his widow and children can claim a share by virtue of their legal rights. However, the fact that legal rights are exigible only out of moveables means that their effects are arbitrary. If a person sold his house shortly before his death and put the proceeds in a building society account legal rights will be exigible. If he had not sold his house at the time of his death no legal rights would be exigible from it or its value. If a person owned a farm at the time of his death, no legal rights would be exigible out of the land or its value. If he owned shares in a company which owned a farm, legal rights would be exigible from the value of those shares. This unjustified distinction between heritage and moveables is the most obvious criticism of the present system. There are others, which we note later, but first we must consider whether legal rights should be preserved at all, and if so, who should be entitled to them.

3.2 In memorandum 69 we set out arguments for and against complete freedom of testation.⁴ We pointed out that public opinion surveys in Scotland had shown that there was strong public support for the idea that a person's surviving spouse and children should have legally protected rights to share in, or at least claim a share in, his property on his death.⁵ We expressed the view that complete freedom of testation was not a viable option. There was no dissent from this view on consultation.

Legal shares or discretionary provision

3.3 There are two main ways of protecting the surviving spouse and issue from disinheritance. One is by way of fixed rights, as in Scotland, and a number of continental European countries. The other is by way of discretionary provision, as in

1. The widow's right is the *jus relictae*: the widower's is the *jus relictii*.

2. In cases of intestacy or partial intestacy the references to moveable estate in this paragraph should be read as references to the moveable estate left after satisfaction of the spouse's prior rights on intestacy under sections 8 and 9 of the Succession (Scotland) Act 1964. See s10(2) of that Act.

3. Succession (Scotland) Act 1964, s11.

4. Paras 4.3 and 4.4.

5. In the 1979 survey in Scotland 95% of informants thought that a surviving spouse should be legally entitled to *some part* of the deceased spouse's estate in spite of omission from the will. In the case of a widowed parent's death, leaving grown-up children, 79% of informants thought that the children should be legally entitled to *some part* of the parent's estate in spite of omission from the will. Manners and Rauta, *Family Property in Scotland* (OPCS, 1981) p21. In the 1986 survey 86% thought the widow should receive, or be able to claim, a share of the estate even though it was left by will to charity and 85% thought the children should receive, or be able to claim, a share. 80% thought one child should receive, or be able to claim, a share even though the whole property was left by will to another child. However only 40% thought the children should receive, or be able to claim, a share where the property was left to the widow. See memorandum 69, pp231-234.

England and a number of Commonwealth countries. Under the latter system the surviving spouse and issue have no fixed rights to a share of the deceased's estate but can apply to a court for a reasonable provision out of it.

3.4 In memorandum 69 we gave details of the English system under the Inheritance (Provision for Family and Dependants) Act 1975 and of some of the variations found in other Commonwealth countries.¹ We pointed out that the system had the advantage of flexibility. The court can take into account the circumstances of each individual case and make an appropriate order. This in turn makes it easier to extend the system to a wider range of people than surviving spouses and children. We pointed out, however, that the system also had disadvantages.² A court application is necessary and the applicant is dependent on the court's discretion. The embarrassment and inconvenience of having to assert a claim may deter many claimants, particularly the less aggressive. There is great room for differences of opinion between judges and for uncertainty about the outcome of an application. The proceedings may involve a distasteful and distressing disclosure of details of the relationship between the deceased and the applicant. The proceedings may be costly and productive of delay in winding up estates.

3.5 We also set out the advantages and disadvantages of a system of fixed legal rights.³ The main disadvantage (apart from remediable defects, like being confined to moveables) is rigidity. The system cannot take account of the merits or demerits of a particular claimant. This in turn means that the class of claimants has to be limited. The advantages of the system are certainty and convenience. There is no need to go to court. This makes the administration of deceaseds' estates a simpler task, avoids erosion of estates by litigation expenses, and avoids distress and uncertainty for surviving relatives, who can be advised immediately of their position.

3.6 Public opinion surveys in Scotland have revealed a fairly even division of opinion on the choice between fixed legal rights and discretionary provision. In the 1979 survey 55% preferred discretionary provision and 42% preferred fixed shares.⁴ In the 1986 survey separate questions were asked in relation to a wife and children. In the case of the wife 42% thought she should receive a fixed share and 44% thought she should have to apply to a court. In the case of the children 40% thought they should receive a fixed share and 45% thought they should have to apply to a court. This was in relation to a widower leaving all his property to charity. Where the hypothetical deceased was a widower who left all his property to one daughter and nothing to his other daughter there was less support for a fixed share for the excluded daughter: 36% favoured a fixed share, as against 44% who thought she should have to apply to a court. Where the hypothetical deceased was a married man who left everything to his wife and nothing to his children the majority (58%) thought the will should stand, while 22% thought the children should receive a fixed share and 18% thought they should have to apply to a court.⁵ Apart from this last case, which introduces the idea of children depriving the widow of her testamentary provisions, the general result of the Scottish surveys is a fairly even division of opinion with a slight preference for a discretionary system.

3.7 In memorandum 69 we expressed the provisional view that in the case of the surviving spouse a system of fixed rights was to be preferred.⁶ This, we thought, was a better way of recognising the surviving spouse's claims to a share of the matrimonial property (by which we mean the property built up by the spouses during their marriage) on the dissolution of the marriage by death. Our provisional view was strongly endorsed on consultation. All except two of the institutional consultees were strongly in favour of a fixed legal right for the surviving spouse. A clear majority of the individual respondents also preferred a fixed legal right for the surviving spouse. The reasons given included the following:

-
1. Paras 4.7 to 4.14.
 2. Paras 4.15 to 4.16.
 3. Paras 4.17 to 4.18.
 4. P21.
 5. Memorandum 69, pp231-234.
 6. Paras 4.21 to 4.26.

“fixed shares remove uncertainty, delay and expense” (Law Society of Scotland)¹

“discretionary Court orders ... are likely to involve distasteful and distressing arguments about past matrimonial disputes and the spouses’ conduct towards each other in general. Such applications would be difficult for the Court to assess and would introduce unnecessary uncertainty into the law” (Faculty of Advocates)

“I am quite sure from experience with a large number of estates that the advantages of certainty outweigh the arguments in favour of a “family provision” arrangement of flexibility and the ability to attend to particular circumstances. My experience leads me to the conclusion that most beneficiaries would rather know precisely how the estate falls to be distributed even if the manner of distribution may not always be ideal and I also fear that the claims may well be pursued most vigorously by those who are least deserving.” (Practising solicitor)

Given the weight of opinion on consultation we have no hesitation in recommending that:

5. The surviving spouse should continue, as of right, to be entitled to a fixed share of the deceased spouse’s estate.

(Clause 5)

3.8 The case for a fixed share for children (legitim) is not so strong. Nowadays children are very often middle aged when their parents die. There is no legal obligation on parents to aliment adult children who have completed their education or training or are over 25.² There is no legal obligation at all on children to aliment their parents. The argument that a legal right for the surviving spouse is a way of recognising his or her claims in the matrimonial property does not apply in the case of children. Indeed there is no very obvious reason why an adult child of the deceased should be able to claim a share of the deceased’s property to the prejudice of the testamentary beneficiary chosen by the deceased. Another consideration is that while a person whose marriage has irretrievably broken down can terminate the marriage by divorce, a person whose relationship with his or her child has irretrievably broken down cannot terminate the relationship. To this extent legal rights for children are less defeasible than legal rights for a surviving spouse: a child cannot be divorced by the parent even if the relationship between parent and child is of the worst type imaginable. We have already noted that in the 1986 public opinion survey there was slightly less enthusiasm for giving children a fixed share than for giving the widow a fixed share. There is a case for giving children, at most, a right to apply for a discretionary provision. On the other hand, there is no evidence of overwhelming dissatisfaction with legitim and a discretionary system would have the disadvantages already noted. For these reasons we reached no provisional conclusion on legitim in memorandum 69 but simply invited views as to whether the children of a deceased person should continue to be entitled to legitim.³ Most institutional consultees favoured the continuation of a system of fixed legal rights for children. There was, however, opposition from the Scottish Landowners’ Federation and the National Farmers’ Union of Scotland who were both concerned to protect the position of the owner who wanted to preserve his agricultural unit by making an appropriate will and who therefore preferred discretionary provisions. There was also opposition from the Scottish Society for the Mentally Handicapped who pointed out that many parents of mentally handicapped children might wish, for reasons which the Society set out at length, to make quite a small provision for the handicapped child and to leave the bulk of their estate to their other children or to a charity concerned with general provision for the mentally handicapped. In some cases the circumstances might be such that the parents wished

1. This comment was made in the Society’s initial comments on memorandum 69 which were based on the recommendations of its Succession Committee made in the light of comments received from local Faculties and individual solicitors. In later comments, dated 30 June 1989, the Council of the Society favoured “some flexibility ... by giving a spouse and descendants the right to apply to the Court for provision to be made for the applicant out of the deceased’s estate of an amount considered to be just and equitable in all the circumstances by the court.” Discussion with a representative of the Society suggested that the Council had in mind a combination of fixed shares and discretionary provision. This, however, would introduce the dangers of uncertainty, delay and expense which the Council was, in its earlier comments, so anxious to avoid.

2. Family Law (Scotland) Act 1985, s1.

3. Para 4.46.

to make greater provision for the mentally handicapped child than for his or her siblings. In both types of case the law on legitim created problems for the parents and placed Scottish families at a disadvantage in relation to similar English families. The Society argued that

“it should not be possible for an automatic claim to disrupt the scheme of a Will which is carefully, responsibly and fairly drawn.”

The Committee of Scottish Clearing Bankers were also opposed, for general reasons, to the retention of legitim. Other institutional respondents, including the Law Society of Scotland,¹ and the Faculty of Advocates, favoured a system of fixed rights for children. Among individual respondents there was a division of views but approximately 60% favoured a system of fixed rights for children.

3.9 The question whether children should be entitled to a fixed share of their deceased parent's estate, even if the parent has chosen to leave his property to someone else, is one of the most fundamental and difficult questions in this whole review of succession law. We received many interesting and carefully argued comments on it, some of them suggesting variations such as confining legitim to dependent children or giving children only a right to claim reasonable maintenance. There is clearly less support for fixed rights for children (particularly adult children) in the face of a will than there is for fixed rights for a surviving spouse. The comments by the Scottish Landowners' Federation, the National Farmers' Union of Scotland and the Scottish Society for the Mentally Handicapped illustrate some of the difficulties which legitim can cause. Other cases can readily be imagined where legitim would frustrate a testator's attempts to achieve what is in his view a rational and responsible distribution of his property. On the other hand there is strong opposition to the idea of discretionary provision for children. In the face of this opposition we do not feel justified in recommending the introduction of a discretionary system.

3.10 There is a stateable argument for confining legal rights to children who are still of an age to claim aliment from their parent. The underlying philosophy of this approach is that a parent has an obligation to support and educate his children to adulthood but has no legal obligation to them thereafter. We gave careful consideration to a scheme based on this approach. Under this scheme only a child under the age of 25 could claim a legal share. (That is the age when the parental obligation of support ceases, even in the case of those undergoing further education or training.²) Moreover a legal share could be claimed only when the deceased was not survived by a spouse from whom the child could claim aliment. If, for example, the deceased was survived by his wife who was the mother of the child or who was a stepmother who had accepted the child into the family,³ then there would be no claim for a legal share: the child could look to the surviving spouse for support. If, however, the deceased was survived by a wife who was not the child's mother and who had not accepted the child into the family and who accordingly was not liable to aliment the child, then there would be a claim for a legal share. The claim for a legal share under this scheme would be for a lump sum representing reasonable aliment until the claimant reached 25 years of age. To prevent claims exhausting modest estates there would be a ceiling of 30% of the whole estate on the total amount that could be claimed by children by way of legal share. Some of us were attracted to a scheme on these lines. It seemed to offer a number of advantages. It recognised that it was difficult to justify giving an adult, aged perhaps 40 or 50, an automatic right to claim a share of property left by his parent to someone else. It confined legal shares for children to cases where it would be generally accepted that there was a parental obligation towards the children, which ought not to be transferred to the state on the parent's death. It would go a long way to meet the concerns of those consultees who objected to legitim. By linking legal share to a commutation of aliment until 25 it would avoid an arbitrary cut-off at 25. Instead there would be a gradual tapering off. A 24 year old student could claim at most one year's support. At the same time

1. This was in the Society's initial comments on memorandum 69. As noted above, the Council in later comments appeared to favour discretionary provisions, possibly as a supplement to legal shares.

2. Family Law (Scotland) Act 1985, s1.

3. See Family Law (Scotland) Act 1985, s1(1)(d).

the scheme would avoid the feared drawbacks of a wide discretionary system. Legal share could be claimed in only a few cases. Quantification could often be by agreement. Even if a case did occasionally have to go to court the issue would be no less justiciable than an action for aliment.

3.11 In the end of the day, while we could see merits in this scheme, we concluded that it was too much at variance with the general results of our consultation and public opinion surveys for us to be justified in recommending it at this time. It may be that this is an option which would be worthy of consideration if succession law is reviewed again in, say, twenty years time. It is not, we believe, an option which would be in accordance with majority opinion at the present time and in this field, more than most others, it is very important that the law should be in accordance with the prevailing climate of opinion. Our conclusion is, therefore, that legitim should not be replaced by either a widely framed discretionary system or an aliment-based system.

3.12 In memorandum 69 we suggested that if legitim were to be retained then the issue of a predeceasing child of the deceased should continue to be entitled to the legitim to which his or her parent would have been entitled.¹ We recognised that the claims of grandchildren to frustrate their grandparent's testamentary intentions were weaker than the claims of children in relation to their parents but also recognised that the law had been changed in 1964 to allow representation in legitim and that it could be anomalous if a grandchild's position were prejudiced by the fact that his parent died, say, a week before rather than a week after the grandparent. All consultees agreed that, if legitim continued, representation in legitim should also continue. We therefore recommend that:

6. The issue of a deceased person should continue, as of right, to be entitled to a fixed share of the deceased's estate.

(Clause 5)

3.13 In memorandum 69 we set out at considerable length the arguments for and against giving certain people other than the surviving spouse and issue claims against a deceased's estate even in opposition to the terms of a will. We reached the provisional conclusion that if such claims were recognised it would have to be by means of discretionary provision rather than legal rights.² This was accepted by all those who commented on it. We propose, however, to re-examine this question, in the case of the cohabitant of long standing, in a future discussion paper. In the meantime, we do not recommend the extension of fixed legal rights beyond the surviving spouse and issue of the deceased.

3.14 The reaction of consultees to the question whether persons other than the surviving spouse or issue should be given a right to apply for discretionary provision was very mixed. There was a division of opinion among both institutional and individual respondents. Some were very firmly opposed—on grounds of vagueness, uncertainty, expense and delay. Some would have extended a right to claim to *de facto* spouses, a smaller number would have allowed children accepted by the deceased into his family to claim, and a still smaller number would have allowed other dependent relatives to claim. There was very little support for conferring a right to claim on other categories. Overall, it is fair to say that the opposition to discretionary provision was stronger than the support for it. There was a great deal of concern, particularly among lawyers, about the dangers of encouraging disputes, litigation, uncertainty, delay and expense.³ There was concern about the distressing effects on bereaved relatives of allowing speculative claims. There was concern that no clear ground for making an award could be laid down and that judges would be given the unenviable and inappropriate task of deciding claims on the basis of sympathy.⁴ We ourselves share

1. Para 4.50.

2. Paras 4.76 to 4.80.

3. The Law Society of Scotland stressed the danger of threatened litigation designed to extract a settlement. "It would be likely that the expenses of such litigation, even if unsuccessful, would be borne from the estate and accordingly a potential claimant could have much to gain and little to lose. There would accordingly be a danger that unworthy claims would be settled in order to avoid such expense."

4. "The law should be made by Parliament and not left to the discretion of the Courts." Law Society of Scotland.

these concerns and we have decided not to recommend the introduction of a system of discretionary provision out of deceased persons' estates. We recognise that there will be cases where a person fails to leave property, deliberately or otherwise, to someone with whom he had close ties during life. It was the clear view of most consultees, and it is our view, that the disadvantages of trying to provide for such cases by a system of discretionary provision would outweigh the advantages. We therefore do not recommend the introduction of a system of discretionary provision out of deceased persons' estates.

No distinction between heritage and moveables

3.15 One of the main criticisms of the existing law on legal rights is that they are exigible only out of moveable estate. This gives rise to needless complications and anomalies and reduces the protection afforded by legal rights.¹ We suggested in memorandum 69 that the legal shares of spouse or issue should be exigible out of the deceased's estate without distinction between heritage and moveables.² This was supported by almost all of those who commented on it. The Scottish Landowners' Federation, however, made strong representations to the effect that there was a very grave disadvantage in giving statutory shares in farms and landed estates to children and spouses (other than perhaps some limited provision for spouses). They pointed out that many landowners wished to leave their estate to one child (or grandchild) in order to preserve a viable unit for the benefit of all those who lived and worked on it. They felt very strongly that the owner of land should be left free to choose as he or she thought best. They did not object, however, to a limited provision for the surviving spouse. The National Farmers' Union of Scotland made similar representations, mentioning the possibilities of a limited share for the surviving spouse (possibly payable over an extended period) and some form of discretionary provision for children, but expressing grave concern that to allow issue to claim a legal share out of heritage could result in farms being split up.

3.16 We take very seriously indeed the points made by the Scottish Landowners' Federation and the National Farmers' Union of Scotland and make recommendations later designed to go some way to meet their concerns. We do not believe, however, that the answer to their concerns is to retain the distinction between heritage and moveables for the purposes of legal shares. The results of this distinction are often arbitrary and unprincipled even in the case of farms and landed estates. If the deceased owned land as an individual it is heritable property in his estate. If he owned shares in a company which owns the land, the shares are moveable property in his estate. If the land was owned by a partnership as partnership property then on the death of a partner the land is treated as moveable for purposes of succession:³ the deceased's property consists of his interest (or *jus crediti*) under the partnership agreement and that is moveable and subject to legitim.⁴ If on the other hand, the land was owned by the deceased partner, either alone or as one of two or more co-owners, and merely occupied by the partnership then it will be heritable in his succession. Even in the case of individual owners the heritable or moveable composition of an estate may depend on such factors as the timing of a sale. Financing arrangements may also affect the composition of an estate as heritable or moveable: a loan secured on land will reduce the value of the heritable proportion of the estate: a loan not secured on land will not. The heritable or moveable composition of a farmer's estate also depends on the nature of the farm and its assets. A valuable herd of pedigree cattle kept on rented land would, for example, increase the moveable component of the estate considerably, as would expensive farm machinery, unless it were so attached to the ground as to be regarded as a fixture and hence heritable. A fish farm using concrete ponds in the ground would be much more "heritable" than one using floating cages

1. See memorandum 69, para 2.4.

2. Paras 4.27, 4.39, 4.47 and 4.49. It will be noted that we refer, from now on, to "legal shares" rather than "legal rights". This is to emphasise that the new scheme is different from the old. It also avoids the problem that all legally enforceable rights, including rights under contract or statute, are legal rights.

3. See the Partnership Act 1890, s22 which, however, does not refer specifically to legal rights.

4. Bell *Commentaries* (7th edn) Vol II p501; *Minto v Kirkpatrick* (1833) 11 S 632.

in the sea. We cannot believe that it is right that the distribution of property on death should depend on such distinctions and considerations. We recommend that:

7. In relation to the legal shares of spouse and issue there should be no distinction between heritable and moveable property.

(Clauses 5 and 7)

Estate subject to legal shares

3.17 It follows from our last recommendation that the legal shares of spouse and issue would be exigible out of the whole net estate of the deceased. We deal later with the definition of “net estate”.¹ We recommend later that a claim for legal share should result in forfeiture of the claimant’s other rights of succession in the deceased’s estate, including rights on intestacy.² This should have the result that legal share would rarely if ever be claimed in cases of total intestacy.

Amount of legal share

Surviving spouse

3.18 Under the present law the surviving spouse’s legal right (*jus relicti; jus relictae*) is to a third or a half of the deceased’s moveable estate depending on whether the deceased is, or is not, also survived by issue. The most obvious reform would be to convert the right into a right to, say, a third of the deceased’s estate, heritable and moveable. In memorandum 69 we provisionally favoured this approach, having considered and provisionally rejected various others, including the idea of a surviving spouse’s liferent.³ It attracted a good deal of support on consultation. Some consultees, however, favoured schemes which would give the spouse a smaller share of a very large estate.

3.19 The Law Society of Scotland considered

“that the provision of a fixed share of one third of the whole estate as legal rights for the surviving spouse would be less satisfactory than a slice system. Any system of legal rights must represent a compromise with testamentary freedom and it is suggested that the relative weight to be attached to these considerations changes as the size of the estate varies.”

The Society therefore suggested that the legal share of a surviving spouse should be one half of the amount to which he or she would have been entitled if the deceased had died intestate. Under the scheme of intestate succession we are now recommending, this approach would not achieve the desired result where there were no issue. In such a case the spouse’s legal share would be a half of the estate, however large it may be. The Law Society’s idea of a slice system could, however, be put into effect more directly, as we note below. Another suggestion for limiting the spouse’s legal share in very large estates was made by the Scottish Landowners’ Federation. They favoured a discretionary system but recognised that, particularly in dealing with small estates, it might be desirable to be able to establish with certainty the exact extent of the legal share of a surviving spouse. They therefore indicated that they would not object to a surviving spouse having an automatic claim to succeed to a share of a deceased person’s estate

“provided that either (i) there was an overall ceiling of say £50,000 on the value of such a claim or (ii) the extent to which heritage could be taken into account for the purposes of assessing the value of a legal rights claim would be limited to around £50,000 or the value of the average family home with any further provision which a spouse may seek requiring to be the subject of an application to the Court”.

1. See paras 9.23 to 9.26 below.

2. See paras 3.45 to 3.48 below.

3. Paras 4.28 to 4.39. The reasons for rejecting a liferent were that (1) in a small estate a liferent would be insufficient for the surviving spouse (2) a liferent could cut out testamentary beneficiaries altogether (if they predeceased the liferenter) or for a very long time (3) a liferent would require arrangements for continuing administration which would be inappropriate in the case of most estates.

The National Farmers' Union of Scotland would also have preferred a discretionary system but recognised that:

"In an effort to recognise the surviving spouse's claim to a share of the 'matrimonial property' it might be that a limited right to a proportion of the estate could be introduced, subject to a threshold, with the possibility of a discretionary 'top-up' by the Court if the spouse's contribution to the 'matrimonial property' had been particularly significant. Consideration might also be given to a liferent to the spouse or to a form of 'buy-out' over an extended period, say ten years".

3.20 We think there is force in the argument that a spouse's claim to a legal share becomes less strong in relation to that part of the estate which is above a certain value. The object of the legal share is to protect the spouse against disinheritance, and to recognise, albeit in an arbitrary way, his or her matrimonial property claims, not to give a very substantial sum against the wishes of the deceased, who has preferred to leave his property to someone other than the spouse. We are therefore attracted by the idea of a slice system, under which the spouse would take a smaller proportion of estate above a certain value. We also think that there is force in the representations made by the Scottish Landowners' Federation and the National Farmers' Union of Scotland. So far as a fixed "ceiling" of, say, £50,000 is concerned we suspect that this would be seen as giving inadequate recognition to the surviving spouse's claim in relation to a very large estate. It would be possible, as suggested by the commentators referred to above, to provide for a discretionary "topping up". However, the objections to discretionary provision in general¹ apply with equal force here.

3.21 The scheme which, in our view, would come closest to remedying the obvious defects of the present law, while meeting the wishes of the majority of consultees and going some way towards meeting the concerns of the landowners and farmers, would be a simple "slice" system with special provision for spreading payment over a period of time in the case of agricultural property. We suggest that the slices should be as follows:

30% of the first £200,000
10% of the excess over £200,000.

The spouse's legal share would, of course, be exigible only out of the *net* estate. So if the relevant property (say, a farm) was heavily burdened with debt it would only be the *net* value which would be subject to the legal share. In comparing the suggested slices with the present law it is important to bear in mind that in the case of an estate consisting entirely of moveables the surviving spouse's legal right, if there are no issue, is already to half the estate. As we note later² a spouse could renounce in advance his or her legal share and, in appropriate cases, this could be used to facilitate rational estate planning.

3.22 We think that where an estate subject to legal shares includes agricultural property which would have to bear the burden of some or all of the legal share payments, it should be possible to pay legal shares by instalments over a number of years. We hope that this (coupled with the slice system) will help to meet the concerns expressed by the Scottish Landowners' Federation and the National Farmers' Union of Scotland. We defer detailed consideration of this proposed instalment system until later.³ We do not think that the surviving spouse's legal share should be reduced merely because the deceased is also survived by issue. The reasons for conferring the right to claim legal share on the surviving spouse are the same whether or not there are issue.

Issue but no spouse

3.23 We made the provisional proposal in memorandum 69 that, if a legal share for issue were to continue at all (about which some of us had grave doubts) then in the absence of a surviving spouse it should be a right to a third of the net estate. This received a considerable amount of support on consultation, but there were also

1. See paras 3.4, 3.7 and 3.13 to 3.14 above.
2. Para 3.31.
3. See paras 3.39 to 3.42 below.

alternative suggestions. Some commentators suggested a slice system. For the reasons given earlier¹ this is the system we ourselves now favour. The claims of the issue are considerably weaker than those of a surviving spouse, there being no argument based on sharing matrimonial property, and we do not think that there could be any justification for giving them a legal share greater than that of a surviving spouse. We think that a slice system on the same basis as for a spouse, with provision for payment by instalments in the case of agricultural property, is probably the best way of reconciling the various interests involved and the various views expressed on consultation. This would mean that, where there was no surviving spouse the issue's legal share would be

30% of the first £200,000 of the net estate
10% of any excess of such estate over £200,000.

Issue and spouse

3.24 Where there is a surviving spouse it would interfere too much with the deceased's testamentary provisions to confer full legal shares on both spouse and issue. This would mean that 60% of an estate under £200,000 would go in legal shares, which would be a great interference with testamentary freedom. In memorandum 69 we put forward various options for dealing with this situation. One which attracted considerable support was to give the issue half their normal legal share if the deceased was also survived by a spouse. Adapting this to the slice system now recommended would mean that the issue's legal share, in a case where there was a surviving spouse, should be 15% of the first £200,000 of the net estate and 5% of any excess of such estate over £200,000. Although this would mean that the legal shares of spouse and issue would absorb 45% of an estate under £200,000, it would be a less drastic interference with testamentary freedom than giving full legal shares to both spouse and issue. It is again worth bearing in mind that in the case of an estate consisting entirely of moveable property the legal rights of spouse and issue absorb two thirds under the existing law.

3.25 It is clear from the 1986 survey that there is much less support for a legal share for children where their claim interferes with a bequest to the surviving spouse. When asked the question "A man leaves all his property to his wife. Should his children receive a share?" 58% of respondents said "No".² Consultation on memorandum 69 also revealed strong support for the principle of restricting the children's legal share where it impinges on the surviving spouse's provisions.³ Some consultees pointed out that in practice children rarely claimed legitim against a surviving parent. It is also worth bearing in mind that in many cases of intestacy under the present law the surviving spouse's prior rights exhaust the estate and preclude any claim for legitim.

3.26 We consider that the best way of dealing with this question of conflict between the issue's legal share and the spouse's succession rights is to provide the surviving spouse with an amount which is protected from claims by the issue for legal share. This amount should, we think, correspond to the amount which the spouse takes, without having to share with the issue, on intestacy. This means that the issue's legal share would not be exigible from the first £100,000 of the net estate to the fee of which the surviving spouse succeeds on intestacy or under any testamentary disposition⁴ by the deceased. If the deceased has left property to his spouse in liferent and a third party in fee, the issue could claim legal share out of the fee. It follows that the usual case in which a child of the deceased would claim legal shares at the lower rates of 15% and 5% would be where there was a surviving spouse but the deceased left some or all of his property by will to a third party. If, for example, the deceased left his whole estate of £60,000 to X, his spouse could claim legal share of £18,000 and his only child could claim legal share of £9,000, leaving £33,000 for X.

1. Para 3.21 above.

2. Memorandum 69, p234.

3. This was discussed in paras 4.58 and 4.59 of memorandum 69. Under the present law a spouse can be better off on intestacy (where prior rights are protected against legitim claims) than under a will which leaves everything to him or her (because the testamentary provisions are not protected against legitim). The spouse may therefore be well advised in some cases to renounce his or her testamentary provisions so as to bring about an intestacy. See *Kerr, Petr* 1968 SLT (Sh Ct) 61. In memorandum 69 we described this result as absurd and most consultees appeared to agree.

4. Including eg a nomination of savings certificates and a survivorship clause in the title to property.

3.27 We recognise that our recommendations mean that a child of the deceased's first marriage would not be able to claim legal share out of estate left to the deceased's second spouse or passing to that spouse on intestacy unless the estate exceeded £100,000. In some cases this could be an unfortunate result. The second spouse might only have known the deceased for a few years. On the other hand any other solution could also have unfortunate results. The second spouse could be a spouse of 40 years standing. Legal shares are, of their essence, fixed and arbitrary. On balance, we think that more acceptable results are likely to be produced across the whole range of different cases¹ by protecting the surviving spouse's first £100,000 of testate or intestate succession rights from the issue's claims to legal share.² If the deceased had wished to benefit his children he could have done so by transfers during his life or, within the adequate scope left by the spouse's legal share, by testamentary provisions.

Interest 3.28 Under the present law a legal rights claimant is entitled to interest on the amount of the claim from the date of death until payment, but there is no fixed legal rate of interest.³ As various factors may be taken into account,⁴ it is difficult to predict the rate which would be awarded by a court. We think that it would be convenient to have a predictable rate. The rate of interest on the spouse's financial sum under section 9 of the Succession (Scotland) Act 1964 is currently 7% per annum. This can be altered by order. A similar rule seems appropriate for legal share.

Recommendations 3.29 Our recommendations on the amount of legal share are therefore as follows.

- 8(a) The surviving spouse's legal share should be**
30% of the first £200,000 of the net estate
10% of any excess of such estate over £200,000.
- (b) Where there is no surviving spouse, the issue's legal share should be**
30% of the first £200,000 of the net estate
10% of any excess of such estate over £200,000.
- (c) Where there is a surviving spouse, the issue's legal share should be**
15% of the first £200,000 of the net estate
5% of any excess of such estate over £200,000
but the estate subject to the issue's legal share should not include the first £100,000 of any net estate to the fee of which the surviving spouse succeeds (otherwise than by virtue of a claim for legal share).
- (d) Interest should be payable on legal share, where it is claimed, from the date of the deceased's death until payment, at the annual rate of 7% or such other rate as may be prescribed.**
- (e) The Secretary of State should be given power to alter the above figures of £200,000 and £100,000 from time to time by statutory instrument.**
(Clauses 5(3) and 7)

Claiming legal shares

3.30 Under the present law legal rights vest on death. In spite of this, it is common in practice to talk of claiming legal rights. Under the scheme which we are now recommending legal shares would not be part of the normal process for working out the distribution of an estate, whether testate or intestate.⁵ They would be a way of preventing disinheritance by will. It is, we think, more consistent with this approach,

1. See para 2.15 above.

2. Where the spouse has both testate and intestate rights, or different kinds of testamentary benefits (eg a special legacy, a general legacy and a share in residue) it is necessary for the legislation to ascribe the protected sum to the different rights or benefits in a certain order. This is done in clause 5(4) of the draft Bill.

3. *Kearon v Thomson's Trs* 1949 SC 287.

4. See *The Laws of Scotland, Stair Memorial Encyclopaedia*, Vol 25, p795.

5. This is because all other succession rights, including rights on intestacy, would be forfeited if legal share were claimed. See para 3.45 below.

and more consistent with the policy of interfering with testamentary provisions as little as possible, to require legal shares to be claimed and to provide that, if not claimed within a certain time, they will not be exigible. This is the approach taken by the Uniform Probate Code in the United States of America in relation to the surviving spouse's forced share.¹ It is also the approach taken by the Irish Succession Act 1965.² If the potential claimant is incapable, by reason of non-age or mental incapacity, of claiming legal share, a claim could be made by any person entitled to act for him in the management of his affairs.³ This would cover, for example, the tutor of a child and the curator *bonis* of a mentally incapable person and also leaves open the possibility of a claim being made by someone acting as a *negotiorum gestor*.⁴ So far as the time for claiming is concerned, we consider that two years from the date of death would be appropriate. This would allow time for a tutor or curator *bonis* to be appointed, where this is necessary. From the point of view of executors it would be a great improvement on the present law under which a claim for legal rights can be made within the 20 year period of the long negative prescription.⁵ An estate could, of course, be distributed earlier. An executor could obtain a renunciation of the right to claim as is often done under the existing law. The period of two years would correspond with the period allowed under section 142 of the Inheritance Tax Act 1984 for the making of a deed of family arrangement varying the distribution of a deceased's estate. We are informed that this time limit causes no significant difficulty in practice. It should be noted that a claim for legal share would not have to be quantified. It could be in quite general terms and could be withdrawn at any time before payment was made. A failure of any potential claimant to claim, or a renunciation after the deceased's death of the right to claim, should not enlarge the legal shares of others. The normal period for claiming would have to be extended in certain cases of presumed death under the Presumption of Death (Scotland) Act 1977 because a considerable time might have elapsed before the date of presumed death was determined. We think that the court granting a decree under the 1977 Act should have power to extend or alter the normal 2 year time limit so as to allow a claim to be made within such period, not exceeding 6 months, as the court may consider appropriate. Where a potential claimant of legal share dies within the two year period from the deceased's death, or the time allowed in a case of presumed death, without having made or renounced a claim, we think that his or her executor should be able to claim and that some extension of the normal two-year limit would be appropriate in this case too. We suggest that the potential claimant's executor should be entitled to claim within 6 months after the date of the potential claimant's death in any case where that would give him a longer period than the normal two years from the date of the first deceased's death. We recommend that:

- 9(a) Legal share should be due only if claimed by the surviving spouse or issue (or, in cases of incapacity, by anyone entitled to act for him in the management of his affairs) within two years from the date of the deceased's death.**
- (b) The court granting a decree of presumed death under the Presumption of Death (Scotland) Act 1977 should have power to extend or alter this time limit so as to allow a claim to be made within such period, not exceeding 6 months from the date of the decree, as the court considers appropriate.**
- (c) Where a potential claimant dies within the normal or extended period for making a claim, without having made or renounced a claim, his or her executor should be entitled to make a claim within that period or within**

1. Ss 2-201; 2-205.

2. S 115(5).

3. See clause 6(2) of the draft Bill annexed.

4. A *negotiorum gestor* is someone who acts gratuitously on behalf of someone else, usually in an emergency, to safeguard or preserve their position but without having been authorised to do so. See eg *Ferrie v Robertson* (1871) 9 M 437. In the case of a pupil or minor a pro-tutor or pro-curator is in a similar position. See eg *Paterson v Greig* (1862) 24 D 1370.

5. Prescription and Limitation (Scotland) Act 1973, ss7 and 8 and Sch 1 para 2(f). See also *Campbell's Trs v Campbell's Trs* 1950 SC 48.

Renouncing legal share

3.31 It should clearly continue to be possible for a person to renounce his or her right to claim legal share, either during the deceased's lifetime or after the deceased's death. There can be no justification for forcing someone to retain a right which exists only for his or her protection. In memorandum 69 we asked whether a renunciation, to be effective, should have to be in subscribed writing.¹ The advantage of such a requirement would be the reduction of uncertainty. There was a mixed reaction to this proposal. Some commentators thought it would be too rigid and that implied renunciation should continue to be possible. In the circumstances we do not feel justified in recommending any change in the law on this point.

3.32 Under the present law the effect of a renunciation of legal rights is different depending on whether it is made before or after the deceased's death. If made before the deceased's death the renunciation enlarges the rights of the others who are entitled to legal rights: the renouncer is treated as if dead. If made after the deceased's death, the renunciation does not benefit the others who are entitled to legal rights but benefits the deceased's residuary legatee or heirs on intestacy. This difference is productive of error and confusion. It appears to be due to the accidents of litigation rather than to any considerations of policy. The effect of a renunciation of legitim during the parent's life was settled in *Hog v Lashley*.² The decision that the renunciation enured to the benefit of others claiming legitim and not to the parent's residuary legatee was unfortunate.³ It meant that a father seeking to buy out his children's rights to legitim had to buy out all his children if he wished to benefit his residuary legatee. If he had four children and bought out all except one then not only was his estate diminished by the price paid to the three renouncing children but also the residuary legatee, if there were no widow, had to suffer a claim to a half of the moveable estate from the fourth child. The question of the effect of a renunciation of legitim after the father's death came up in *Fisher v Dixon*⁴ and gave rise to a remarkable division of opinion. The court, being bound by *Hog v Lashley*, had a difficult choice. Either it drew a distinction between pre-death and post-death renunciations (which some judges thought was unjustified and unsatisfactory) or it extended the rule of *Hog v Lashley* to post-death renunciations (which other judges thought was unsatisfactory).⁵ In the end the Court of Session decided, by 7 to 6, in favour of drawing the distinction between pre-death and post-death renunciations, and this was affirmed by the House of Lords. The intellectual basis of the distinction was that legitim vested on death. After that date each child could deal with his or her own share and could transact with the residuary legatee as creditor and debtor without affecting the shares of the other children. A similar distinction between pre-death and post-death renunciations of the surviving spouse's legal right, the former enlarging legitim to half the moveables but the latter leaving legitim at a third of the moveables, was later recognised.⁶

3.33 Under our recommendations legal shares would no longer vest automatically on death. They would arise only if claimed. If not claimed the deceased's will would take effect as intended. In this new situation it is possible, and indeed necessary, to re-open the old controversy. It seems to us that in the new scheme the important question is simply whether or not a potential claimant has claimed within the time

1. Para 4.64.

2. (1792) 3 Paton 247.

3. As had been recognised by the Lord Ordinary. See *Hog v Hog Mor.* 8193 (1791)

4. (1840) 2 D 1121, aff'd (1843) 2 Bell's App. 63.

5. An extension to post-death renunciations would have meant, for example, that if a father provided each of his three children with a legacy in lieu of legitim and if two accepted the legacy, the residuary legatee had to bear the loss of the two legacies without there being any resulting diminution in the amount payable as legitim. It also meant that one child could not know how much legitim he was receiving or renouncing until the others had made their election.

6. *Campbell's Trs v Campbell* (1862) 24 D 1321.

limit. The reason for not claiming should be immaterial. It should make no difference whether the person had renounced the right to claim before the deceased's death, or after his death, or not at all. If a claim is not made within the time limit, for whatever reason, then the amount which could have been claimed will simply pass under the deceased's will. The reason for renouncing legal share will usually be either that the deceased has made other provision for the potential claimant or that the potential claimant wishes to assure the testator that he will not disturb his testamentary provisions. In either event the renounced amount should, in fairness, be available to the deceased's testamentary beneficiaries. In the case of a "purchase" by the deceased, during his life, of a child's right to claim legal share this does mean that the other children will take a share of a smaller total. However that is a risk they have to accept: the deceased is free to diminish his estate during his life as he chooses. It is, in our view, desirable that a testator should be able to transact with each potential claimant for the renunciation, for the benefit of the intended testamentary beneficiaries, of that claimant's right to claim. Although the preceding discussion has been mainly in terms of claims for a child's legal share similar considerations apply to claims for the spouse's legal share. In other words, a renunciation of legal share by a spouse should not enlarge the legal share claimable by issue.¹ We therefore recommend that:

10(a) It should be competent to renounce (either during the deceased's lifetime or after his death) the right to claim legal share.

(b) A renunciation (whether before or after the deceased's death) or a failure to claim legal share within the time limit should not enlarge the legal share of any other potential claimant.

(Clauses 5(5) and 7(5))

We considered whether recommendation 10(b) should apply only to renunciations made after the date of commencement of the new legislation. This restriction was suggested by the Law Society of Scotland. The argument for it is that the effect of a legal transaction ought not to be changed after it has been entered into. We accept this argument in general. In this particular instance, however, we do not think that it has much force. The effect of the renunciation on the renouncer remains unchanged. All that is changed is the indirect potential effects on others and that is always uncertain. A person renouncing legal rights in another person's estate during that person's life has no way of knowing what the effects on others will be when that person dies. The estate may be greater or less or non-existent. It may have changed from being largely moveable to being largely heritable. The other person may have made such testamentary provisions that no legal rights are claimed. Other potential legal rights claimants may have predeceased. The law on succession and legal rights may have changed. So far as the other potential claimants are concerned they have no rights to claim until the death occurs and have no ground for complaint if their rights are governed by the law in force at that time.

Collation of advances

3.34 The idea of collation is that a person who has received advances or benefits from the deceased during the deceased's lifetime should be required to add the value of these advances or benefits back into the deceased's estate, or the relevant part of it, if he claims a share of that estate or part on the deceased's death. In Scots law this idea has never been applied generally. Under the present law it is recognised only in relation to claims on the legitim fund and even there is recognised only in a limited way. In this section we consider whether collation of advances or benefits should be required by someone claiming legal share. We begin with the surviving spouse.

3.35 Under the present law there is no provision for collation of advances or other benefits by a surviving spouse. So a spouse can receive a substantial gift from the

1. Clause 7(2)(b) of the draft Bill achieves this result by providing that if the deceased is survived by a spouse the issue's claim is at the lower rates of 15% of the first £200,000 and 5% of the rest. This applies whether or not the spouse claims legal share.

deceased during his lifetime or generous provision by way of insurance policies and pension rights, and still claim legal rights. In memorandum 69 we examined various alternative possibilities. We pointed out that provision for collation by a spouse would lead to complexity, difficulty¹ and expense and might not be seen as necessary. We doubted whether it would be widely perceived as unjust if a widow received her legal share in addition to the proceeds of a life insurance policy or occupational pension scheme. We pointed out that if a person wished to make some exceptional provision for his spouse during his lifetime so as to be able to leave his whole estate by will free from his spouse's claim for legal share he could easily make the provision conditional on a renunciation of the right to claim legal share. We expressed the provisional view that there should continue to be no requirement on a surviving spouse to collate advances and other benefits as a condition of claiming his or her legal share.² This was agreed by nearly all who commented.

3.36 So far as legitim is concerned there is in the existing law a rule of collation. In its simplest form this means that a child taking legitim can be required by other children taking legitim to add back into the legitim fund certain advances received from the deceased during his lifetime. Not all advances have to be collated.

“The advances which must be collated are limited to those which affect the legitim fund. Thus they do not include payments in discharge of a parent's natural duty of maintenance and education of his child, nor do they include payments by way of remuneration for services which arise out of an onerous contract. Loans made to the claimant for legitim are not advances to be collated under this doctrine, for they are due to the deceased's executor and form part of the deceased's gross estate from which the legitim fund is computed. Advances made out of the deceased's heritage are not subject to collation *inter liberos*, because they do not affect the moveable fund from which legitim is computed. Testamentary provisions, as distinct from *inter vivos* advances, need not be collated, as they do not affect the legitim fund. Such testamentary provisions, in so far as they are moveable, are paid out of dead's part of which the deceased was completely free to dispose. In any event, if the beneficiary of such a testamentary provision accepted it, he could not also claim legitim unless there was a partial intestacy, and, if he is not a claimant for legitim, no one can require the collation of advances made to him. Finally, even if *inter vivos* advances of a type otherwise appropriate for the operation of this doctrine have been made, the donor may expressly or impliedly have indicated that the recipient's right to legitim is to be unaffected thereby.

The typical examples of advances which may have to be collated in securing the equitable division of the legitim fund are advances to set the recipient up in trade, for a marriage portion or for settlement in a station in life.”³

When legitim was made available, by representation, to grandchildren and remoter descendants in 1964 it was provided that any such claimant should

“be under the like duty to collate any advances made by the deceased to him, and the proportion appropriate to him of any advances so made to any person through whom he derives such entitlement, as if he had been entitled to claim such legitim otherwise than by [representation]”⁴

It is by no means clear what is meant by an appropriate proportion in this context.⁵ If, for example, the deceased is survived by five grandchildren, one of them the son of a predeceasing son and the other four the daughters of a predeceasing daughter, and if there was a collatable advance of £1,000 to the son during his lifetime, must the grandson collate the whole £1,000 or only £400 (on the view that as his father would have had to collate £1,000 to obtain half the legitim fund he should only have to collate £400 to receive a fifth of it)?

1. One difficulty would be in valuing the benefits (eg pension benefits) to be collated.

2. Para 4.68.

3. Meston, *The Succession (Scotland) Act 1964 (3rd edn)*, p48.

4. Succession (Scotland) Act 1964, s11(3).

5. See Meston “Collation of Advances to Ancestors” 1967 SLT (News) 195 and subsequent letters at pp 224 and 247.

3.37 In memorandum 69 we raised the question whether the requirement of collation by legitim claimants should be abolished.¹ We thought it was open to doubt whether a parent making an advance to a child would expect it to be set against that child's legal share in his estate. If a person wished an advance to be treated as a loan rather than a gift he could easily make it as a loan. We agreed with the view of the Law Reform Commission of British Columbia that the function of the rules on intestate succession

“is to distribute what remains of the [deceased's] estate after his death, not to remedy any injustices which may have occurred during his lifetime.”²

Most of those who commented on this question were in favour of abolishing collation. The Law Society of Scotland commented that it was extremely rare in practice and that sums paid to a child were normally either outright gifts (not intended to be collatable) or loans. They favoured abolition. The Faculty of Advocates pointed out that it was unsatisfactory that a child claiming legitim had to collate advances if anyone else was taking legitim but did not have to collate if no-one else was taking legitim. They too thought that collation should be abolished. We recommend that:

11. There should be no requirement to collate advances and other benefits as a condition of claiming legal share.

(Clause 5(6))

Incidence of legal shares

3.38 We did not discuss the incidence of legal shares in memorandum 69 because, apart from removing the exemption for heritable property, we were not proposing any change. We are now recommending a completely new system of statutory legal shares.³ In these circumstances it is necessary for the rules on incidence to be stated. Although legal share can be regarded for some purposes as a statutory legacy of the amount payable⁴ this approach will not do for purposes of incidence. As general legacies abate before special legacies this approach would mean that legal share could be defeated by special legacies which exhausted the estate. It is of the essence of legal shares that they should not be capable of being defeated by any testamentary provision or special destination. We recommend that:

12(a) The amount due by way of legal share should be taken out of the estate in the following order unless the testator provides to the contrary:

(i) intestate estate

(ii) residue

(iii) general legacies

(iv) special legacies, nominated property and property passing under a special destination.

(b) This recommendation is subject to the proviso that the estate subject to the issue's legal share should not include the first £100,000 of any property to the fee of which the surviving spouse succeeds, otherwise than by virtue of a claim for legal share.

1. Para 4.70.

2. *Report on Statutory Succession Rights* (1983) p39. It is also interesting to note that in New Zealand and three Australian jurisdictions (New South Wales, Queensland and Western Australia) “there is now no requirement that intestate successors bring into account *inter vivos* benefits received from the intestate. The hotchpot doctrine has been abandoned because of its uncertainty, its complexity, its diminishing relevance, and the difficulties of administration which it produces.” Hardingham, Neave and Ford, *Wills and Intestacy in Australia and New Zealand*, p343.

3. Clause 5(6) of the draft Bill abolishes “*jus relictii*, *jus relictiae* and legitim, and any ancillary rules of law relating thereto”. This removes the old law on collation *inter liberos*, for example, but it also removes the rules on the incidence of legal share.

4. See para 9.25 below where this approach is suggested in relation to the expenses of administration.

(c) Within each of the above categories different items should bear a rateable proportion of legal share according to net value.

(Clauses 5(3) and 9)

Agricultural property

3.39 We have already mentioned the concerns expressed by the Scottish Landowners' Federation and the National Farmers' Union of Scotland as to the effects of legal shares on agricultural property. These concerns are reasonable and understandable. Before we consider various ways in which they could be met, it might be useful to give an example of how legal shares would work in relation to a farm if no special provision were made.

Example

The testator owned and worked a farm with a capital value of approximately £500,000 (including livestock, machinery and other moveables). He is survived by a wife and two sons. He leaves his whole estate to the elder son. The widow and younger son claim legal shares. Let us suppose that the net estate after debts and funeral expenses is £460,000.¹ Legal shares are as follows.

| | | | | |
|---------------|--|---------|---------|-----------------|
| <i>Spouse</i> | 30% of £200,000 | = | £60,000 | |
| | 10% of £260,000 | = | £26,000 | |
| | | | | £86,000 |
| <i>Son</i> | 15% of £200,000 | = | £30,000 | |
| | 5% of £260,000 | = | £13,000 | |
| | | | | £43,000 |
| | | | | <u>£21,500</u> |
| | Whereof the half share of one out of two sons is | £21,500 | | £21,500 |
| | Total legal shares claimable | | | <u>£107,500</u> |

The widow's share would be exempt from inheritance tax.² The son's share would have to bear a proportion of the inheritance tax due from the estate.³ From the point of view of the elder son the amount payable for legal shares is a very substantial sum. The fact that, even after inheritance tax and legal shares he is very much better off than he was before does not resolve the problem, in "an industry rich in wealth and poor in cash",⁴ of finding the money to make the necessary payments without selling part of the farm. Yet from the point of view of the widow the amount she can claim (and she might not necessarily wish to claim, or to claim the full amount, in all circumstances) might not seem excessive if she wishes to buy and furnish a house at current prices and still have enough to provide a modest income. From the younger son's point of view the amount he receives, when compared with the value of the estate, might not seem excessive either. The difficulty is the same as that faced by many farmers in making their wills under the present law: it is impossible to reconcile a painless transfer of the whole farm to one son or daughter with reasonable provisions for the widow and other sons or daughters.

3.40 We have given a great deal of thought to possible solutions to the difficulty of meeting claims for legal shares out of agricultural property. One extreme solution would be to exempt agricultural property from legal shares. This, however, would be unprincipled. Quite apart from the fact that some agricultural property is owned as an investment, often along with substantial other property, it would be unfair on

1. We are assuming that inheritance tax is not deducted at this stage. See para 9.24 below and *cf* Inheritance Tax Act 1984 s42(4).

2. Inheritance Tax Act 1984, s18, s41 and s42(4).

3. Inheritance Tax Act 1984, s42(4). The amount of inheritance tax payable by the son would depend on such factors as the precise amount of agricultural relief available under s116 of the 1984 Act.

4. C W Pagan, "Farm Taxation Planning" in *Aspects of Agricultural Law* (Law Society of Scotland, 1981) p60.

farmers' spouses to deprive them of rights available to all other spouses. In an extreme case such an exemption for agricultural property could leave a widow and teenage children completely unprovided for. We do not think that that would be acceptable.

3.41 Another solution would be to place an upper limit on the amount that could be claimed by way of legal shares out of agricultural property—say, £50,000 for the spouse's share and £20,000 for the children's share. This would be less extreme, and more attractive, but it would be an arbitrary solution which would again discriminate against the spouses and issue of the owners of agricultural property. In recommending a scale of rates for legal shares with a rate of 10% for the spouse out of the excess of property over £200,000 we have attempted to meet the concerns about massive claims out of large estates but to do so in a general way which can be applied to all kinds of property.

3.42 We have already mentioned the suggestion made to us on consultation that, if legal shares were to be payable out of agricultural property, provision should be made for them to be paid out by instalments over a period of years. We think that this is a valuable suggestion. We suggest that where legal share has to be paid, having regard to the rules on incidence mentioned above, out of agricultural property the executor should have the option of paying it by not more than ten equal annual instalments with interest at 7% per annum (or such other rate as may be prescribed) on any instalment from the date it falls due until payment. The first instalment should be treated as falling due on the date of the deceased's death. In many cases the executor would wish to transfer the property, subject to the burden of paying the outstanding instalments, to the person entitled to it. We see no reason why this should not be done. It would be in the executor's interest to ensure that the instalments were properly secured over the property. If the agricultural property is sold, or if part of it is sold for a price equal to or greater than the unpaid balance of the legal share,¹ then the reason for allowing payment by instalments flies off and any outstanding instalments should become due immediately. The definition of agricultural property should be similar to that in section 115(2) of the Inheritance Tax Act 1984. The right to pay legal share by instalments, *with interest due only on any instalment which is paid late*, is a substantial concession which should, in at least some cases, enable legal share to be met wholly or mainly out of income. We hope that this right will go a long way to meet the concerns expressed to us about legal shares out of agricultural property. We accordingly recommend that:

13. Provision should be made, on the lines set out in paragraph 3.42, to enable legal share out of agricultural property to be paid in instalments over a period of not more than ten years.

(Clause 11)

3.43 It is perhaps worth pointing out in relation to agricultural property that a testator could take steps during his lifetime to minimise legal share claims on his death. He could, for example, obtain a renunciation of the right to claim legal share in exchange for some other form of provision, such as a liferent or life annuity. It is also perhaps worth noting that a farm can continue to be run as a unit even if there are two or more proprietors with undivided shares. Quite complicated co-ownership situations can arise under the existing law on succession, without this necessarily resulting in the loss of a farm as a working unit.²

3.44 The above discussion has been in terms of owned farms. In a case of succession to a tenant farmer the main problem, for present purposes, is in deciding what value, if any, should be placed on the tenancy. It now appears to be accepted that in certain cases the tenancy will have a value. This will depend on such matters as tenant's improvements, any difference between the rent payable and a fair rent, and the date of the next rent review.³ It will also depend on the duration of the lease and the amount of time left to run. We do not think that it would be helpful for legislation

1. In the case of two or more sales of separate parts, the price for this purpose should be the total price.

2. For an example, see *Bell v IRC* 1985 SLT (Lands Trib) 52.

3. Penrose, "Tenancies and Taxation" in *Aspects of Agricultural Law* (Law Society of Scotland, 1981) pp87-89.

to intervene by, for example, specifying a special method of valuation for the purposes of legal share.

Effect of claiming legal share

3.45 We suggested in memorandum 69 that a person claiming legal share should forfeit all rights in the deceased's estate under the law of intestate succession and, unless the deceased expressly provided otherwise, all testamentary provisions from the deceased.¹ This was agreed by all those who commented on it. The principle is that legal share is intended as a protection against disinheritance and not as an extra share in addition to other rights under the law of succession. Claiming legal share is not to be encouraged, and a potential claimant should know that if he or she claims legal share that is all that he or she will get from the deceased's estate. This principle extends not only to testamentary provisions properly so called but also to will substitutes such as nominations and survivorship clauses. So a wife claiming her legal share would forfeit her husband's one-half share of their house if the house was in joint names with a survivorship clause, just as she would have forfeited that half share if there had been no survivorship clause and her husband had left it to her by will. Any other rule would introduce a quite arbitrary and unjustifiable distinction between cases where succession to the deceased's share was regulated by a survivorship clause and cases where it was regulated by a will.

3.46 What should happen to the forfeited share or provision? In memorandum 71 we suggested that, in general, and unless the deceased provided otherwise, the forfeiting claimant should be treated, for the purposes of succession to the deceased's estate, as having predeceased the deceased.² This was agreed by almost all of those who commented.³ The claimant's deemed predecease should not, of course, affect other legal shares. A claim by a surviving spouse should not enlarge the amount claimable by issue: a claim by a son should not allow his issue to claim legal share as if he had predeceased the deceased. Moreover the issue of the forfeiting claimant should not take the whole or part of the forfeited provisions as representing the claimant. A child who is left a legacy of the same value as his legal share should not be able to claim legal share for himself in order to let his own children take the legacy in his place (eg by virtue of a conditional institution in the will leaving the legacy to the child whom failing his issue, or by virtue of a deemed conditional institution⁴ or because it has fallen into intestacy).⁵ The same rule should apply to anyone called as a conditional institute to the claimant. If the deceased left £5,000 to his son whom failing to X, it is unlikely that he would have wished X to take if his son took, say, £6,000 out of the estate by way of legal share instead of his legacy of £5,000. Indeed there would be an obvious danger of collusion between a claimant and a conditional institute if the latter could take a provision forfeited by the former. Suppose that a son has been left £6,000 by his father's will and that his legal share is worth £5,000. Normally he would not claim legal share. However, if his bequest of £6,000 is to him whom failing X, and if X is allowed to take the bequest if it is forfeited by the son, then it would be in X's interests to offer him, say, £2,000 to claim legal share. The son would then receive £7,000 (£5,000 plus his "fee" of £2,000) and X would receive £4,000 (£6,000 minus the "fee" of £2,000). The deceased had intended to leave £6,000 to either his son or X. His estate, however, would have to pay out £11,000 to the son and X. It seems to us, therefore, that the position of a conditional institute who is not a child of the claimant should be no different from the position of a conditional

1. Para 4.63.

2. Para 4.31.

3. See, however, Gretton "Vesting, Equitable Compensation and the Mysteries of the Shadow Liferent" 1988 SLT (News) 149.

4. See para 4.65 below which recommends a statutory replacement of the *conditio si institutus* of the common law. See also clause 17 of the draft Bill which provides for this.

5. This result, which seems clearly desirable as a matter of policy, is not always achieved by the present law. The present law does not necessarily regard a provision to a child whom failing his issue (as conditional institutes) as forfeited for the issue if the child claims legitim, although it can hardly be imagined that the testator would have intended both to take. See eg *Munro's Trs v Munro* 1971 SC 280.

institute who is. In both cases the claimant should forfeit the provision not only for himself but also for anyone called as a conditional institute in his place. If the testator wishes the conditional institute to take the bequest not only if the institute fails to survive the testator's death but also if he does survive but claims legal share (which seems a most unlikely wish) then he can provide expressly for this. We recommend that:

14. Subject to any contrary directions by the testator the effect of a claim for legal rights should be as follows.

- (a) **A person claiming legal share should forfeit all rights in the deceased's estate under the law of intestate succession and all testamentary provisions from the deceased and all provisions of a quasi-testamentary nature (eg by nomination or survivorship destination).**
- (b) **For the purposes of succession to the deceased's estate (otherwise than by way of legal share) the forfeiting claimant should be treated as having predeceased the deceased.**
- (c) **A claimant's deemed predecease should not have the effect of enabling anyone to take the forfeited provisions in his place by virtue of representation on intestacy, or as a conditional institute under the deceased's will, or as a deemed conditional institute.**

(Clause 8)

Paragraph (b) of the above recommendation is intended to bring about the acceleration of vesting if, for example, the deceased left a fund to the claimant in *liferent* and A, whom failing B, in *fee*. The claimant would be deemed to have predeceased the testator and A would take an immediate vested right and immediate possession. This is the most sensible result in this situation.¹ The reference to the *deceased's* estate would prevent certain unwanted results in relation to survivorship destinations. If the deceased and his wife held their house in joint names with a survivorship clause and if the wife claimed her legal share she would forfeit her right to take the deceased's half-share on his death but she would not be treated as having predeceased in relation to her own half-share because what happens to that has nothing to do with succession to the deceased's estate.

3.47 The rules recommended above would apply without difficulty in cases of partial intestacy. Suppose, for example, that a testator is survived by one child, and no widow. He leaves a legacy of £90,000 to a friend but makes no provision for residue. His net estate is £100,000. The child claims legal share (£30,000). Applying the above rules would result in the £10,000 of intestate estate being forfeited by the child. The child's claim would be met first out of this intestate estate and only the balance (£20,000) would come out of the legacy.²

3.48 Some further examples may help to show how the recommended rules would operate.

Example 1

A testator is survived by his wife and son. His net estate is £100,000. He leaves it to his wife in *liferent* and his son in *fee*. His wife claims her legal share (£30,000). The wife forfeits all interest in the estate. The son (who has a vested right in the *fee*) takes immediate possession of the remaining estate. So the result is:

| | |
|------|----------|
| Wife | £30,000 |
| Son | £70,000 |
| | £100,000 |
| | £100,000 |

Notice that in this case the son takes the *fee* in his own right. He is not a conditional institute: his right to the *fee* is not conditional on his mother failing to survive the testator. So his right is not forfeited by the claim for legal share.³

1. We recommend later that a similar result should follow from the renunciation of a *liferent*. See para 9.17 below.
 2. See the rules on incidence recommended in para 3.38 above.
 3. The present law is the same. See *Fisher v Dixon* 10 S 55; 6 W & S 431; *Snody's Trs v Gibson's Trs* (1883) 10 R 599; *Hurll's Trs v Hurll* 1964 SC 12.

Example 2

The facts are as in Example 1, but the wife does not claim legal share. The son seeks advice as to whether he should claim his legal share. If he did he would receive £15,000 in fee, but would forfeit all other interest in the estate. His forfeited interest in the fee would fall into intestacy and would pass to the wife.

Example 3

A widow is survived by two children. She leaves a legacy of £10,000 to one child and the residue of her estate to the other. Her net estate is £100,000. The first child claims legal share (£15,000).¹

The claimant forfeits the legacy, which falls into residue. Legal share comes out of residue. So the result is:

| | |
|-----------|----------|
| 1st child | £15,000 |
| 2nd child | £85,000 |
| | £100,000 |
| | £100,000 |

If the claimant child has a child there is no question of that child taking the forefeited legacy as a deemed conditional institute.² The claimant forfeits the legacy for himself and any issue representing him.

Example 4

A testator is survived by one child, a brother and no widow. He leaves a small plot of land (worth £20,000) to his child, a legacy of £90,000 to a cousin, and makes no provision for residue.³ As it happens, his estate is £100,000. So there is no residue and the cousin, if no legal share is claimed, would get £80,000 (because general legacies abate before special legacies). The child claims legal share (£30,000).

The child forfeits the land, which falls into intestacy. Legal share comes out of the intestate estate first. The remaining legal share (£10,000) comes out of the remaining estate. So the result is

| | |
|--------|----------|
| Child | £30,000 |
| Cousin | £70,000 |
| | £100,000 |
| | £100,000 |

Example 5

A testatrix, survived by one child and no husband, leaves a legacy of £10,000 to a friend and the residue (£1,000) to her child whom failing to X. The child claims legal share (£3,300).

The forfeited £1,000 falls into intestacy and is used to meet the legal share. The remaining £2,300 of legal share comes out of the legacy. So the result is

| | |
|--------|---------|
| Child | £3,300 |
| Friend | £7,700 |
| | £11,000 |
| | £11,000 |

Example 6

A testator is survived by his wife and one child. His net estate is £100,000. He leaves it to his child in *liferent* and a charity in fee. The wife and child both claim legal share.

1. As there is no surviving spouse, the total legal share fund is £30,000 (ie 30% of £100,000). As there are two children each is entitled to claim half this amount (ie £15,000). See clause 7 of the draft Bill.
 2. Ie under the new statutory equivalent of the *conditio si institutus* introduced in clause 17 of the draft Bill.
 3. This example is similar to one given by Mr Gretton in his article at 1988 SLT (News) 149.

| | |
|-------------------|-------------|
| The wife takes | £30,000 |
| The child takes | £15,000 |
| The charity takes | £55,000 |
| | <hr/> |
| | £100,000 |
| | <hr/> <hr/> |

Example 7

A testator is survived by his wife, one child and a sister. His net estate is £100,000. He leaves it to a young friend in *liferent* and the child in *fee*. The wife and child both claim legal rights.

| | |
|---|---------|
| The wife takes | £30,000 |
| The child takes | £15,000 |
| The friend takes a <i>liferent</i> of the remaining £55,000. | |
| The <i>fee</i> of the £55,000 falls into <i>intestacy</i> and goes to the testator's sister, payment being postponed until the death of the <i>liferenter</i> . | |

Example 8

A testatrix, who is not survived by a husband, leaves her estate (£100,000) to her daughter in *liferent* and the daughter's two sons in *fee*. The testatrix provides that her daughter's two sons are only to take the *fee* if her daughter does *not* claim legal share. If she does claim legal share the share of capital destined to her in *liferent* and her sons in *fee* is to go to X in *liferent* and Y in *fee*. The daughter claims legal share.

The daughter is deemed to have predeceased the testatrix. Normally her sons would take the estate left after legal share has been paid. But here the terms of the will provide otherwise and the remaining estate goes to X in *liferent* and Y in *fee*.¹

Example 9

A testatrix leaves her estate (£42,480) to her husband in *liferent*. On his death $\frac{3}{5}$ of the capital is to be paid to her son (whom failing, his issue) with vesting postponed until the date of payment, and $\frac{2}{5}$ is to be held for her daughter in *liferent* and a grandson in *fee*. The husband and daughter claim legal share. The son does not.

The husband's legal share is £12,744. He forfeits his *liferent* and is deemed to have predeceased the testatrix.

The daughter's legal share is £3,186. She forfeits her *liferent* but this does not affect the grandson's independent *fee*. She too is deemed to have predeceased the testatrix.

As the husband and daughter are both deemed to have predeceased the testatrix, the son and grandson take their shares ($\frac{3}{5}$ and $\frac{2}{5}$ respectively) of the remaining capital (£26,550) immediately. So the result is

| | |
|----------|-------------|
| Husband | £12,744 |
| Daughter | £3,186 |
| Son | £15,930 |
| Grandson | £10,620 |
| | <hr/> |
| | £42,480 |
| | <hr/> <hr/> |

Compare the simplicity of this solution with the complications, on similar facts, of *Munro's Trs v Munro*.²

Example 10

A widow leaves her estate (£100,000) to her only son in *liferent* and, after his death, for his daughter in *liferent* and the daughter's issue, whom failing X and Y, in *fee*. The son claims legal share (£30,000).

1. See *Campbell's Trs v Campbell* (1889) 16 R 1007; *McCauill's Trs v McCauill* (1900) 3 F 222; *Tindall's Trs v Tindall* 1933 SC 419.
2. 1971 SC 280.

The son forfeits his liferent for himself but not for his daughter (who is not a conditional institute, but could have taken in due course even if the son *had* taken the liferent). The son is deemed to have predeceased the testatrix. So the daughter's liferent is accelerated and the remaining estate is held for her in liferent and her issue, whom failing X and Y in fee.

Again compare the simplicity of this solution with the complications, on similar facts, of *Rose's Trs v Rose*¹ where it was held that vesting in the daughter was not accelerated and that the income of the estate had to be used to make equitable compensation in some way which the court was unable to specify.

Anti-avoidance provisions

3.49 There are at least three possible approaches to attempts to defeat, by *inter vivos* transfer, claims for legal share. The first is to do nothing. The second is to deal with the more obvious cases of avoidance. The third is to attempt to deal with all cases. We consider the first two in the following paragraphs. The third is not, in our view, a realistic option. It would require legislation of the complexity of inheritance tax provisions designed to counter devices adopted to prevent property passing on death. The complexity of the provisions required, and the difficulty of applying them, would be quite disproportionate to the mischief to be remedied

3.50 The "do nothing" approach is that currently adopted in Scots law. It has the great merit of simplicity. It can be supported on the view that the purpose of the law of succession is only to regulate succession to the property left by the deceased at death and not to interfere with what he does with his property during his life. It might also be argued that avoidance measures would be most likely to be taken in cases where, in the view of the deceased, his spouse or children or other issue had no moral claims against him, that often the view of the deceased would be justified and that, given the arbitrary nature of fixed legal shares, the result of the "do nothing" approach would not necessarily be greater injustice.

3.51 There are various ways in which the law could deal with the more obvious cases of avoidance without attempting to deal comprehensively with all cases. One way would be to provide that for the purposes of calculating the estate subject to legal shares the property owned by the deceased at death and passing under his will should be notionally augmented by the value of specified dispositions made by him during his lifetime (without the consent of those entitled to claim legal shares) otherwise than for full consideration.² The specified dispositions might be:

- (a) any disposition of property of which the possession, enjoyment or income was retained by the deceased at the time of his death
- (b) any disposition to the extent that it could be revoked, or diverted to his own benefit, by the deceased at the time of his death
- (c) any gifts made within a certain period before death, other than gifts below a certain value and gifts made out of income as part of the deceased's normal expenditure.

A provision on the above lines would leave many avoidance devices open. The purpose would not, however, be to defeat all attempts at avoidance but merely to counter the more obvious attempts and to make avoidance more difficult. Even limited provisions of this nature could, however, lead to complications and difficulties in practice. Quite apart from the difficulties of applying the provisions and valuing the property in question, there would be the problem of knowing what to do if the property left in the deceased's actual estate was not enough to satisfy the legal shares. In this type of case the recipients of the property disposed of by the deceased would presumably have to be made liable to contribute to the estate in proportion to the value of the property received.³ That would lead to further practical problems.

1. 1916 SC 827.

2. This kind of approach is adopted by the Uniform Probate Code S 2-202.

3. Cf the Uniform Probate Code s2-207.

3.52 Another way of dealing with the more obvious avoidance attempts would be to concentrate on the deceased's intentions and to give the courts powers to counteract transfers within, say, three years before death which are proved to have been intended to defeat claims for legal shares. This is the approach taken by the Irish Succession Act 1965.¹ It gives the court power to order any such disposition to be deemed, in whole or in part, to be a bequest by the deceased and to form part of his estate. The court also has power to make orders to the effect that the donee shall owe the estate such amount as the court may direct. Like the approach considered in the previous paragraph, this type of provision would not deal with all avoidance devices. It would be difficult or impossible, in many cases, to prove the requisite intention, and transfers outwith the time limit would escape.

3.53 Our provisional view in memorandum 69 was that it would be undesirable to introduce anti-avoidance measures. We were not satisfied that there was a great need for them or that they would add greatly to overall justice. We were satisfied that they could never be fully effective and that they would complicate the law and the administration of estates.² There was a division of opinion among those who commented on this question. A majority agreed with our provisional view and opposed the introduction of anti-avoidance provisions. The Faculty of Advocates, for example, considered

“that in view of the average level of estates involved, the incidence of avoidance would be very small and would not justify the relatively complex anti-avoidance provisions which would be required. Such provisions would in our view be extremely difficult to make effective and would unnecessarily complicate the law and the administration of estates.”

The Council of the Sheriffs' Association agreed

“that anti-avoidance provisions are neither necessary nor desirable...”

The Scottish Landowners' Federation and the Committee of Scottish Clearing Bankers took the same view as did a majority of the individuals who commented on this question. The Law Society of Scotland noted that the assimilation of heritage and moveables would, in itself, counter the obvious device of investing in heritage to minimise legal shares. They did not, however, think that this was sufficient and suggested that the deceased's estate should be augmented by including the value of

“(a) any disposition of property of which the possession, enjoyment or income was retained by the deceased at the time of his death; and

(b) any disposition to the extent that it could be revoked, or diverted to his own benefit, by the deceased at the time of his death.”

They did *not* think that outright gifts or gifts under which the deceased did not retain an interest should be open to challenge. They were therefore prepared to accept a situation in which anyone wishing to reduce the impact of legal shares could very easily achieve this result. The Scottish Law Agents Society also favoured some limited anti-avoidance provision based on augmenting the deceased's estate by including the value of specified dispositions made by the deceased. Professor Meston favoured an anti-avoidance measure based on a power in the courts to set aside transfers made within a specified period before death with the intention of defeating, or substantially diminishing, the value of legal shares.

3.54 We have not found this an easy question, given the conflicting arguments and the different views expressed on consultation. In the end, however, we have concluded that the need for anti-avoidance measures, in practical as opposed to theoretical terms, has not been established. The risk of attempts to defeat morally justified legal shares is probably greatest in the case of a spouse who is separated and awaiting a divorce. However, in this situation the spouse with a claim for financial provision on divorce has remedies available to forestall attempts to avoid that claim.³ He or she can, for example, apply for an interdict against any transaction which would

1. S121.

2. Para 4.106.

3. Family Law (Scotland) Act 1985, s18.

be likely to have the effect of defeating his or her claim in whole or in part. Transactions made within the previous five years can be varied or set aside. These remedies would have the incidental effect of protecting the spouse's claim for legal share should the other spouse die before the divorce. In the case of a normal marriage which has not broken down we are not satisfied that there is a practical need for anti-avoidance measures. Nor are we satisfied that there is any need for such measures, which could never be fully effective in any event, in relation to the claims of children or remoter issue. Indeed we think that such measures could, in some cases, interfere with reasonable estate planning designed, for example, to pass capital from grandparent to grandchildren while missing out the intermediate generation, already well provided for. Accordingly we make no recommendation for the introduction of measures to counteract lifetime transactions designed to avoid, or reduce the impact of, legal shares.

Part IV Testate Succession

Validation of certain wills

The problem 4.1 It can easily happen that a document intended by a person to take effect as his will fails to take effect because of inadequate execution. For example, the testator may have subscribed a typed or printed will but may have failed to have his subscription attested or to add the words “Adopted as holograph” above his signature.¹ Or, in the case of a holograph will, he may have signed at the top or the side instead of at the bottom.²

Example

In one Scottish case³ the deceased had written out in her own hand, a few days before she died, a document which began:

“I, *Ethel F Costello*,

I will all the money I have to John J Foley, who is to pay two legacies out of it . . .”

There followed directions as to the legacies, a request for cremation, and a request to her doctor to verify beyond all possibility of doubt that death had really taken place. There was no signature at the end. In the two days before her death Miss Costello told two people that she had made her will and told one of them its contents. Just before her death she pinned the document quoted above to the breast of the nightdress she was wearing. It was held that the document was not a valid will. Although there was little or no doubt that she intended it to be her will, and although it contained her signature in the opening line, the requirement of subscription at the end was not satisfied.

Another type of case is where the deceased has left an unsigned document in an envelope which has been signed on the outside.⁴ There may also be cases where, due to some accident or interruption, a document which was clearly intended to take effect as a will is not signed by the testator at all. In one Australian case, for example, a solicitor had drawn up similar wills for a husband and wife. Unfortunately the husband signed the wife’s will in error and she signed his. The mistake was discovered only after the husband’s death.⁵ A Scottish example was mentioned by the Very Reverend Dr Andrew Herron in commenting on our consultative memorandum.

“An elderly lady living alone and having a bit of money laid by was visited one afternoon by a couple who were passing and wanted merely to hand something in. ‘O,’ she greeted them, ‘you’re the very folk I’m looking for—come on in.’ She went on to say she had just been making her will and was looking for a couple of witnesses and they were ideal for the purpose; she didn’t want to ask any of the neighbours, they were all so nosey’. She then produced a document of the printed variety duly completed except for the signatures. Without first adhibiting her own signature she got her friends to sign, and then spotting a neighbour (of the ‘nosey’ variety) approaching her door she stuffed the document in a drawer and hurriedly began a conversation on the weather. Some little time later she died and the unsigned document was found in the drawer. She had no relatives, but the Queen’s Remembrancer hardened his heart against any appeal on behalf of the frustrated

1. See eg *Tucker v Canch’s Tr* 1953 SC 270.

2. See eg *McLay v Farrell* 1950 SC 149. In England it is no longer necessary that the testator’s signature be at the foot or end of the will: Administration of Justice Act 1982, s17.

3. *Foley v Costello* (1904) 6 F 365.

4. See eg *Russell’s Trs v Henderson* (1883) 11 R 283. In this case the will was sustained, but see *Taylor’s Exs v Thom* 1914 SC 79 which suggests that a different decision might be reached today.

5. *In the Estate of Blakely, Decd* (1983) 32 SASR 437.

beneficiaries. The witnesses were prepared to testify to the whole circumstances and they themselves had no interest under the will, but in light of [the existing law] there seemed little point in trying to get the document set up. I don't know that the Queen would be noticeably the richer, but a few decent folk in Paisley were appreciably the poorer!"

A partial solution 4.2 The obvious answer to problems caused by excessive formal requirements is to reduce these requirements to the acceptable minimum. This is the course we have recommended in our recent report on *Requirements of Writing*.¹ We there recommended that the only requirement for the formal validity of certain legal documents (including wills) should be subscription by the granter.² This would enable some wills which must at present be regarded as invalid for technical reasons to be valid and effective.³ It is, however, only a partial solution. It would not help in cases where the testator had signed somewhere else than at the end of the document or in cases where he had not signed at all.

A dispensing power? 4.3 Several jurisdictions have introduced provisions enabling a court to hold a will valid notwithstanding technical defects in its execution.

4.4 In Israel section 25 of the Succession Law 1965 provides that

"where the court has no doubt as to the genuineness of a will, it may grant probate thereof notwithstanding any defect with regard to the signature of the testator or of the witnesses, the date of the will, the procedure set out in sections 20 to 23 or the capacity of the witnesses."

The section has been found to be useful. One Israeli judge is quoted as saying:

"The provisions of section 25 do not tend to 'increase litigation, expense and delay'. On the very contrary it has been my experience that advocates are gradually attaching less and less importance to defects in the form of a will since they are aware of the court's approach, and will not oppose probate merely on the grounds of such defects. I am, therefore, of the opinion that section 25 actually prevents a great deal of unnecessary litigation and saves time and expense . . ."⁴

4.5 In South Australia the law was amended in 1975 to provide that:

"A document purporting to embody the testamentary intentions of a deceased person shall, notwithstanding that it had not been executed with the formalities required by this Act, be deemed to be a will of the deceased person if the Supreme Court, upon application for admission of the document to probate as the last will of the deceased, is satisfied that there can be no reasonable doubt that the deceased intended the document to constitute his will."⁵

This provision enabled the will to be validated in the case of *Blakely*, mentioned above, in which the husband mistakenly signed his wife's will instead of his own.⁶ It has been found to be "a useful and practically applicable remedy".⁷ A similar provision has been enacted in the Northern Territory⁸ and in Western Australia⁹ and

1. Scot Law Com No 112 (1988).

2. Paras 4.13 to 4.41.

3. It would, for example, lead to a different result in a case like *Walker v Whitwell* 1916 SC (HL) 75 where an undoubtedly genuine will was denied effect because one of the two witnesses had not signed the will until after the testatrix's death. It would also validate wills prepared on printed will forms and signed but not adopted as holograph or attested.

4. Law Reform Commission of British Columbia, Report on *The Making and Revocation of Wills* (Report No 52, 1981) pp45-46.

5. Wills Act Amendment Act (No 2) 1975, inserting a new s12(2) in the Wills Act. This implemented a recommendation of the Law Reform Committee of South Australia in its 28th Report (1974).

6. See also *In the Estate of Williams* (1984) 36 SASR 423 (Will witnessed but, by mistake, not signed by testator. Extrinsic circumstances left no reasonable doubt that document intended to be will. Will admitted to probate.); *In the Estate of Hollis* (1984) 37 SASR 27 (Testator signed first three pages of his will but not the fourth and last page. Witnesses signed all four pages. Will admitted to probate.).

7. Comment by the Registrar of Probates of South Australia quoted in the Report of the Law Reform Commission of British Columbia on *The Making and Revocation of Wills* (Report No 52, 1981) at p45.

8. Wills Amendment Act 1984, s5.

9. Wills Amendment Act 1987, s9, implementing the Report of the Law Reform Commission for Western Australia on *Wills: Substantial Compliance* (1985).

has been recommended for New South Wales.¹ Queensland has a more limited provision applying only to testamentary documents executed “in substantial compliance” with the statutory formalities² but, as we observed in memorandum 70, this is an unclear test which could lead to difficulties in interpretation.³

4.6 In Canada a provision similar to the South Australian provision has been enacted in Manitoba.⁴ It applies the normal civil standard of proof (instead of requiring proof beyond reasonable doubt, as in South Australia) and expressly applies to alterations and revocations. The British Columbia Law Reform Commission has recommended a similar provision which, however, would apply only if the document had been signed by or on behalf of the deceased.⁵

Case for a dispensing power

4.7 The argument for a dispensing power is that it enables effect to be given to obviously genuine wills notwithstanding technical defects. The need for it clearly depends on the nature of the requirements for formal validity, but even if these are reduced to subscription by the testator a dispensing power could still be useful for cases where the testator signed somewhere else than at the end of the will or where he did not, through mistake or oversight, sign the will at all. The essence of the argument for a dispensing power is that

“Formalities for the validation of a document are a means to an end and not an end in themselves.”⁶

The requirement that the court must be satisfied that the purported will was intended by the deceased to take effect as his will is a safeguard against abuse. The onus would be on anyone seeking to set up the purported will. It would be up to him or her to satisfy the court that the document was intended by the deceased to take effect as his will. If a court is so satisfied, a refusal to give effect to the purported will would be a refusal, on no more than technical grounds, to give effect to what a court has decided were the deceased’s genuine testamentary intentions.

Case against a dispensing power

4.8 One argument against a dispensing power is that it would lead to excessive “litigation expense and delay”.⁷ However, excessive litigation does not appear to have been a problem in Israel or South Australia where such a power has been in existence since 1965 and 1975 respectively. In South Australia there were 39 cases in the first 10 years of operation of the new provision and only 4 of these cases were contentious.⁸ A dispensing power would not be worth introducing if it was never likely to be used but, on the evidence from South Australia, it does not seem likely that it would lead to a flood of litigation.⁹ It might be argued that even one or two contested cases a year would be too many on the ground that the expenses would diminish the estates to the profit of lawyers and the prejudice of the beneficiaries. This, however, would be a question for the beneficiaries under the defectively executed wills to assess in deciding whether or not to seek to have the wills upheld. Similar

1. Report on *Wills—Execution and Revocation* (1986) pp65-79. A Bill has been introduced to implement this report.

2. Succession Act 1981-83, s9. A somewhat similar provision has been recommended for Tasmania. Tasmania Law Reform Commission, *Report on Reform in the Law of Wills* (Report No 35, 1983) p10.

3. Para 2.8.

4. Wills Act 1983, s23. This implemented recommendations in the Manitoba Law Reform Commission’s Report on *‘The Wills Act’ and the Doctrine of Substantial Compliance* (Report No 43 1980) pp25-30.

5. Report on *The Making and Revocation of Wills* (Report No 52 1981).

6. Miller, “Substantial Compliance and the Execution of Wills” 36 ICLQ (1987) 559 at 587. See also the important article by Langbein, “Substantial Compliance with the Wills Act” 88 Harv LR (1975) 489.

7. See the 22nd Report of the (English) Law Reform Committee at p4.

8. Law Reform Commission of Western Australia, *Report on Wills: Substantial Compliance* (1985) paras 3.10, 5.9 and 8.15. Some of the cases were almost certainly concerned with wills which would have been valid in any event under the present Scots law. South Australia does not recognise holograph wills and had stricter requirements as to attestation than Scots law. Many of the cases were certainly concerned with wills which would be valid anyway if the recommendations in our report on *Requirements of Writing* were implemented. The breakdown of the cases was (i) will not signed by testator 4 (ii) testator’s signature unwitnessed 7 (iii) will not signed or acknowledged in presence of two witnesses present at same time 15 (iv) alterations and additions 8 (v) will not signed at foot or end 5. See the Report of the Law Reform Commission of Western Australia, cited above, para 5.9. The 22 cases in categories (ii) and (iii) would not have arisen under a reformed Scots law because witnessing would not be essential for validity.

9. In 1985 the population of South Australia was about 1,373,000.

assessments have to be made under the present law—in relation, for example, to such questions as whether a document is adequately subscribed, or whether a partly printed and partly handwritten document is sufficiently holograph to be formally valid. The potential for totally unfounded claims, perhaps made with a view to extracting a settlement based on their nuisance value, would be limited because the claimant would have to be named as a beneficiary in a defectively executed will. The class of potential claimants is not open ended but is, on the contrary, extremely restricted.

4.9 A second argument against a dispensing power is that it would increase the risk of fraud and forgery: it would, in particular, make it easier for documents to be passed off by the unscrupulous as the wills of vulnerable old people. Any increased danger of fraud would be a matter of concern which would weigh heavily in the balance against the introduction of a dispensing power. It must be stressed, however, that before the dispensing power could be exercised a court would have to be satisfied that the document in question was intended by the deceased to take effect as his or her will. The more suspicious the circumstances, the less likely is a court to be satisfied on this point. There is no reason to suppose that the courts would be more indulgent to dubious ill-executed documents than they are to dubious improbatively subscribed documents. In relation to the latter they have been strict.

“Whenever there is room for suspicion or doubt as to what really was the deed or the sheets which the testator really intended to subscribe, the Court will refuse to sustain the deed. The Court will always, and rightly, exact the clearest proof upon this point, and this seems to be an ample and sufficient guarantee. It is really the only guarantee against fraud in this and in all cases.”¹

It must also be stressed that even if a will were validated under the dispensing power this would merely prevent objections based on *formal* invalidity. It would not prevent the will from being challenged on such grounds as *facility* and *circumvention*.²

4.10 A third argument against a dispensing power is that the power would be difficult to exercise. Again, however, this does not appear to have been the case in South Australia,³ and the courts already have to decide in certain cases whether a document represented the testator’s testamentary intentions.⁴ A reading of the Scottish cases on wills which were not properly subscribed suggests that in many of them there could have been little or no doubt as to testamentary intention. In any event it would be for the person seeking to rely on the document to satisfy the court that it was intended to take effect as the deceased’s will. If the court was not satisfied the application would be refused.

4.11 A fourth argument against a dispensing power is that it might lead to a careless attitude to the execution of wills: people would not bother subscribing but would either not sign at all or would sign anywhere on the document. This argument has only to be stated to be seen to be unrealistic. Nobody wants to make difficulties for their heirs or executors. People who do not know the law will not be led into careless habits by the existence of a dispensing power. People who do know the law will normally try to execute their wills in the way which is likely to lead to least trouble for their successors.

Consultation 4.12 The majority view on consultation was that a dispensing power would be useful. Most consultees who supported a dispensing power favoured, as we ourselves then did, a dispensing power limited to documents signed by the testator. They also strongly favoured a dispensing power in relation to alterations, including unsigned and uninitialled alterations.

Conclusions 4.13 We think that reform of the law is desirable in this area. Some of the reported cases where courts have been forced to deny effect to defectively executed wills

1. *McLaren v Menzies* (1876) 3 R 1151 per Lord Gifford at 1170.

2. See eg *Ross v Gosselin's Exs* 1926 SC 325; *McDougal v McDougal's Trs* 1931 SC 102; *West's Tr v West* 1980 SLT 6; *Wheelans v Wheelans* 1986 SLT 164.

3. See Miller, “Substantial Compliance and Wills” 36 ICLQ (1987) at p552.

4. Eg in deciding whether a document is a will or a mere memorandum of instructions.

cannot be read without a feeling that the law ought to be able to do better than this in giving effect to the wishes of testators. We have no doubt that there are also cases which never reach the courts where everybody concerned recognises that a document was intended by the deceased to be his or her will but where the document cannot take effect as a will because of some formal defect, such as the deceased's signature being in the wrong place. We do not regard this as satisfactory. Nor do we regard the present law on unauthenticated deletions and alterations as satisfactory. It is illogical that an unauthenticated deletion can receive effect, if the court is satisfied that it was made by the testator with the intention that it should have effect, but that an unauthenticated addition cannot.¹ There can be no doubt that a suitably worded dispensing power would enable a number of undoubtedly genuine but defectively executed wills, and alterations to wills, to receive effect as the testators intended. The South Australian experience suggests that fears of adverse consequences are groundless. We therefore agree with the majority of the commentators on our memorandum that a dispensing power should be introduced.

4.14 We have given further thought to the form a dispensing power should take. We do not favour a dispensing power limited to cases where there has been "substantial compliance" with the normal requirements. That leaves matters very vague. Nor do we favour a dispensing power limited to cases where the testator had "attempted to comply" with the normal requirements. That raises a question as to whether it must be proved that the testator knew what the normal requirements were. More fundamentally, both these tests seem to be based on the assumption that the value to be protected is respect for the rules on formal validity. This seems to us to be the wrong approach. The value to be protected is respect for genuine expressions of final testamentary intention. We think, however, that the power should be confined to written expressions of testamentary intention. It would open up too much uncertainty to allow oral expressions of testamentary intention to be validated. We appreciate that many of the arguments in favour of giving effect to genuine expressions of testamentary intention, provided that a court is satisfied that they are such, apply to oral expressions of intention and that there is, therefore, something arbitrary about confining a dispensing power to written documents. The justification for this limitation is a practical one. There would be too much scope for dispute as to the content of oral expressions of intention and too much scope for fraud. It may be that this argument would not apply to certain types of oral will, such as a tape-recorded will or a video-recorded will. Indeed in certain circumstances a tape-recorded or video-recorded will would provide more satisfactory evidence of genuine testamentary intention than a written will. We did not, however, consult on this and we are not aware that tape-recorded or video-recorded wills are a practical problem at the present time. We therefore think it safer to confine our recommendations in the meantime to written documents. The question of tape-recorded or video-recorded wills could be examined at a later date if it proves to be a real problem in practice.

4.15 The question which has caused us most concern is whether the dispensing power should apply only to writings signed, somewhere, by the testator. In memorandum 70 we were inclined to favour this approach, although we thought that unsigned and uninitialled alterations to a will ought to be capable of being validated if a court was satisfied that the testator intended them to take effect as part of his will.² We pointed out that a requirement of signing would cut down the number of difficult cases where there might be doubt as to completed testamentary intention and could be particularly useful if a number of unsigned documents were found in a testator's repositories after his death. Such a requirement would also reduce opportunities for fraud and, by cutting down the number of particularly difficult cases, would reduce any danger of delay and expense caused by the introduction of a dispensing requirement. It would represent a more cautious reform and it is arguable that it is better to begin cautiously in introducing such a new power, while reserving the possibility of extending its scope later in the light of experience. As we have already mentioned, most consultees favoured a dispensing power confined to signed documents, but also favoured a dispensing power for alterations, including unsigned and uninitialled alterations. This

1. See *Pattison's Trs v University of Edinburgh* (1888) 16 R 73.

2. Paras 2.15 to 2.19.

was one of the questions on which we specifically sought the views of the Law Society of Scotland in a supplementary consultation. Not only did the Council of the Society adhere to its earlier view that the testator's signature should be required but it also, somewhat to our surprise, advocated requirements, such as a requirement that non-holograph wills be subscribed on every page, which would in some respects be more strict than the present law.¹ There are clearly weighty considerations, and weighty consultees, in favour of at least a requirement of signature by the testator before the dispensing power can be exercised. This is not an onerous or unreasonable requirement. People are generally aware that a document such as a will must be signed before it is legally effective. There are also, however, arguments the other way. A dispensing power limited to signed documents would not cover all the cases where such a power would be useful. It would not cover the type of case where, because of mistake, oversight or interruption, a testator omits to sign even though the circumstances leave no room for doubt as to his or her intention that the document should take effect as his or her will. It would not meet the case where a husband and wife mistakenly sign each other's wills. Nor would it meet the type of case where an unsigned will is contained in a signed and sealed envelope and where the present law cannot be stretched far enough to allow the signature on the envelope to be regarded as the subscription of a will. Yet another type of case was brought to our attention during discussions with a representative of the Law Society of Scotland on this question. This is the case where a purported notarial execution is carried out on behalf of a person who is unable to write by a person who is not qualified to act as a notary. The will, let us suppose, is written out on the testator's instructions, read over to him or her by the "notary" in the presence of two reputable witnesses, and subscribed by the "notary" on behalf of, and with the authority of, the testator. Everything is honest and open. The will is reasonable in its terms and confers no benefit on the "notary" or the witnesses. There is no doubt as to the testator's testamentary intentions. Yet the will is not signed by the testator. Another argument in favour of not having a requirement of signature is that it is difficult to justify having one rule for alterations, which might be very important and might in effect rewrite a will, and another rule for wills. It is therefore arguable that the absence of a signature on a purported will should be regarded as a factor which should, and undoubtedly would, weigh heavily with a court in deciding whether the document did represent the deceased's concluded testamentary intentions, but should not be an absolute bar to relief. On this view, the key to a proper assessment of the dispensing power, and the answer to supposed difficulties and dangers, is that a court would have to be satisfied that the document in question was intended by the deceased to take effect as his will. It is here that the necessary element of caution would be introduced. Courts would be unlikely to be satisfied that an unsigned document represented the testator's concluded intentions unless this was very clear from the circumstances. If it was clear from the circumstances, then to insist on a signature would be unnecessary and undesirable.

4.16 We have found this a very difficult issue. There are good arguments both ways. It is a question of weighing the possible dangers and disadvantages of allowing an unsigned document to be set up as a will (if a court is satisfied as to the testator's intention) against the advantages of being able to give effect to testators' wishes in some, but probably not very many, cases. On balance, we have come to the conclusion that a signature should not be required for an exercise of the dispensing power.

4.17 We have already noted that most of those who supported a dispensing power thought that it should apply to unauthenticated alterations to a will. This would be one of the most useful applications of the power. It is not uncommon for testators

1. Under the present law a typed will which is adopted as holograph and subscribed at the end is valid without any need for subscription of pages other than the last. Moreover a typed will which is subscribed at the end by the testator and attested by two witnesses is valid under section 39 of the Conveyancing (Scotland) Act 1874 even if not subscribed on any other page, provided that it is proved that it was subscribed by the testator and by the witnesses by whom it bears to have been attested. In other words, the will is formally valid but, because of s44(2) of the Conveyancing and Feudal Reform (Scotland) Act 1970, not probative. We would not recommend a return to the pre-1874 position.

to assume that alterations are covered by the original execution of the will,¹ an assumption which can give rise to particular difficulty where words have been deleted and replaced by others, which are not authenticated. The deletion takes effect (if proved to be done with revoking intent) but the substituted words do not. This has given rise to the idea of conditional revocation—that the deletion is conditional on the alteration taking effect²—in order to prevent a complete gap. The result is to give effect to the testator's earlier wishes instead of his last wishes. It would be much more satisfactory to enable effect to be given to the new words if the court is satisfied that they were inserted with the requisite intent. One body of consultees expressed doubt about the use of a dispensing power in relation to alterations. They said:

“If it is considered that unauthenticated alterations are to be acceptable the law should be amended to say that. It should not be left to the Court to cure the matter by the exercise of a dispensing power.”

It would, however, be out of the question to allow unauthenticated alterations to a will to take effect without proof that they had been made by the testator with the intention that they should receive effect. It is perhaps worth stressing that what is proposed is not an open-ended discretionary power but a power to be exercised on, but only on, proof that the alteration was made by the testator with the intention that it should receive effect. This is no different in substance from the present law on unauthenticated deletions which take effect if proved to be made by the testator with revoking intention. We have already noted that the South Australian provision has been found useful in relation to alterations and additions.³ In case there is any doubt on the point we suggest that it should be made clear that the dispensing power applies to documents which merely revoke prior testamentary documents.

4.18 Where an application is successful the court would make a finding that the writing was intended by the deceased to take effect as his will, or as an alteration or revocation of his will. The writing should then take effect as if it were formally valid and duly attested. As a rule of Scots law, this would help those founding on the will only if the question of formal validity were governed by Scots law. The fact that the writing took effect as if it were formally valid would not, of course, prevent a subsequent challenge on any ground of substantial invalidity. In practice, subsequent challenges should be extremely rare as the facts would normally be fully investigated at the time of the original application. It would be useful if the court could also, where necessary and appropriate, make a finding as to the date when, period within which or place where the will, alteration or codicil was made or executed. So far as the standard of proof is concerned we can see no sufficient reason for departing from the normal civil standard.⁴ It would be anomalous to apply the criminal standard of proof to only one of the many issues which can arise in relation to a will in a civil case.

4.19 We recommend that applications for the exercise of the dispensing power should be competent either as independent applications to the Court of Session or a sheriff court or as incidental to other proceedings, including proceedings for the confirmation of an executor. The sheriff courts having jurisdiction in independent applications should, we suggest, be the courts of the sheriffdom in which the deceased was last domiciled. If he was domiciled outside Scotland or his domicile was unknown, any independent application could be made to the sheriff court at Edinburgh. Procedure would be a matter for rules of court but we envisage that rules would provide for intimation of any application to all persons not already parties but appearing to have an interest, including those who would stand to inherit if the application were

1. The present law on the authentication of alterations to a will is not free from doubt, but generally the alteration must be signed or initialled by the testator. See our report on *Requirements of Writing* (Scot Law Com No 112) paras 4.44 to 4.47. In that report we recommended that post-execution alterations should require to be signed or initialled. We thought that unauthenticated alterations in wills could best be dealt with by a dispensing power of the type now recommended.

2. *Pattison's Trs v University of Edinburgh* (1888) 16 R 73. We discuss conditional revocation further at para 4.77 below.

3. Law Reform Commission of Western Australia, *Report on Wills: Substantial Compliance* (1985) para 5.9.

4. This is also the view of the Law Reform Commissions of Manitoba, British Columbia and Western Australia. See the reports cited earlier in this part.

unsuccessful. Where a defectively executed will, or a will with a defectively executed or unauthenticated alteration, has already been registered in the Books of Council and Session or in sheriff court books it should, we suggest, be possible to register in the same register an order of the court validating the will or alteration. Where the will has not already been registered it should be possible to register the will and the court order in the same register at the same time. We have discussed with the officials concerned the question of cross indexing (so that someone looking up the original will would find a reference to the order of the court) and have been informed that suitable arrangements could be made.¹

Recommendations 4.20 We recommend that:

- 15(a) The court should be given power to declare to be formally valid a writing which purports to be a will, an alteration to a will, or a revocation of a will, notwithstanding failure to comply with the normal requirements for formal validity, if the court is satisfied (extrinsic evidence being admissible for this purpose) that the testator intended it to take effect as his will, or as an alteration to or revocation of his will.**
- (b) Where the court is so satisfied it should make an order to that effect, and the writing would then have effect as if it were formally valid and duly attested.**
- (c) The court making an order should have power to make a finding as to the date when, period within which, or place where, the writing was executed or made.**
- (d) An application should be competent either as a separate proceeding in the Court of Session or a sheriff court or as an incidental application in other proceedings, including proceedings for the confirmation of an executor.**
- (e) Rules of Court should provide for an application to be intimated to persons not already parties but having an interest, including any person who would succeed to any part of the deceased's estate if the application were unsuccessful.**
- (f) Provision should be made for the order of the court to be registrable in the Books of Council and Session or sheriff court books if the writing is already registered there or if it is being registered there at the same time.**

(Clause 12)

Rectification of wills

The problem 4.21 Although non-testamentary writings can be rectified where they fail to give effect to the intentions of the granters (eg because of a clerical error)² there is no provision for rectification of testamentary writings. It follows that, after the testator's death, there is no way of correcting even simple and obvious errors. The following are examples of the types of error which can quite easily occur.

Example 1

A typist in copying a will from an approved draft erroneously misses out some words. The effect is to deprive a residuary legatee of all benefit.³

Example 2

Instead of leaving legacies of £10,000 each to the testator's daughters Georgiana and Florence, as instructed by the testator, the will, because of a clerical error, leaves two legacies of £10,000 to Georgiana and fails to mention Florence. The will is sent to the testator for signature along with a summary of its provisions. The testator reads the summary, which mentions legacies to Georgiana and Florence, but does not read the whole will. He signs it without noticing the error.⁴

1. Similar problems arise under the present law in relation to variations of trusts.

2. Law Reform (Miscellaneous Provisions)(Scotland) Act 1985, s8.

3. *Cf In re Reynette-James* [1976] 1 WLR 161.

4. *Cf In the Goods of Sir J E Boehm* [1891] P 247.

Example 3

An insurance agent, asked to prepare a will relating only to an insurance policy, erroneously includes a clause revoking prior wills. He believes, in good faith, and assures the testatrix, that this has effect only in relation to the insurance money. In fact it has general effect and contrary to the testatrix's intentions and instructions, revokes her prior will entirely.¹

Example 4

A solicitor, instructed by a testatrix to revoke clause 7(iv) of a will, mistakenly and carelessly revokes the whole of clause 7.²

Our provisional proposals

4.22 In memorandum 70 we provisionally proposed that provision should be made for the rectification of wills which failed to express the testator's intentions because of a clerical error or a failure to carry out his instructions.³ This proposed solution was similar to that introduced in England and Wales by section 20 of the Administration of Justice Act 1982 which provided that:

"If a court is satisfied that a will is so expressed that it fails to carry out the testator's intentions, in consequence

- (a) of a clerical error; or
- (b) of a failure to understand his instructions,

it may order that the will shall be rectified so as to carry out his intentions."

Our proposal, however, was intended to cover the case where a solicitor understood the testator's instructions but (for some reason other than a clerical error) failed to carry them out.⁴ To this extent it was slightly wider than the English solution.⁵ We also proposed provisions on time limits for applications (6 months from confirmation unless the court permitted a later application) and on protection for trustees or executors who acted on the will as unrectified. A problem which gave us some difficulty was whether rectification should be available in relation to an error of expression made by a testator in writing out or typing his own will. We pointed out that in such a case there would be no independent instructions with which the will could be compared. It would be inconclusive and possibly undesirable to lead evidence of the testator's general intentions. He might have changed his mind. He might not have been frank about what he intended to put in his will. We invited views specifically on this question.

Consultation

4.23 There was very strong support from consultees for the introduction of a power to rectify wills where they failed, because of clerical error or some other reason, to give effect to the testator's instructions.⁶ The few dissenters gave reasons which we do not find convincing. It was suggested, for example, that the possibility of

1. *Cf Collins v Elstone* [1893] P 1.

2. *Cf Re Morris, decd* [1971] P 62.

3. Para 3.4.

4. We have been interested to note that the New South Wales Law Reform Commission has also concluded that this type of case ought to be covered by a rectification provision. Report on *Wills—Execution and Revocation* (1986) paras 7.20 to 7.25. The Commission cite an Australian case—*Kent v Brown* (1942) 43 5R (NSW) 124; 66 CLR 670—where, in preparing a trust document, a solicitor erroneously used a form of words which gave certain beneficiaries only a life interest, and not a right of fee as instructed by the settlor. The solicitor had understood the settlor's instructions. The error was not a mere clerical error. As the deed was an *inter vivos* one, the court was able to rectify, although the settlor was dead (as would also now be the case in Scotland under section 8 of the Law Reform (Miscellaneous Provisions)(Scotland) Act 1985). The New South Wales Law Reform Commission saw no reason why rectification should not also be available, in this type of situation, in the case of wills.

5. The English solution has been criticised as too narrow. See Mithani, *Rectification of Wills* (1983) Law Society's Gazette 2589 at pp2590-2593; Maxton, *Rectification of Wills: A Case for Reform* (1984) New Zealand Law Journal 142 at p147.

6. The Law Society of Scotland initially supported rectification but later, in supplementary comments submitted in June 1989, changed its view. Discussion with a representative of the Society suggested that the reason for the change of view was concern that rectification might go beyond mere clerical errors or other errors of expression. We considered whether we could meet the Society's concern by using some such words as "because of a clerical error or other error in expression" in the draft Bill. We concluded (a) that "clerical error" was merely one type of error in expression and added nothing (b) that to concentrate on error in expression would be too narrow because it would exclude cases where the drafter of the will, not being in any error, deliberately failed to give effect to the testator's instructions.

rectification would encourage spurious claims by disappointed beneficiaries. The answer to this is that proof of the testator's general intentions would not be sufficient: there would have to be proof that the will failed to carry out the testator's instructions. It was also suggested that a claim for damages for negligence against a solicitor who failed to carry out the testator's instructions would always provide an adequate remedy. This, however, is not necessarily true¹ and, in any event, allowing a defective will to take effect while awarding damages against a solicitor seems a less satisfactory solution than rectifying the will. It was also said that a testator ought to read his will carefully before signing it. This is true but not all testators will do so and not all will be alert enough to notice that, say, a reference to clause 7(iii) ought to have been a reference to clause 7(iv). It was argued that errors in wills could be rectified by deeds of family arrangement. This is true provided all those with an interest agree, but they may not and that is when judicial rectification would be useful.

4.24 There was a division of opinion on allowing rectification of a will prepared by the testator himself. Those opposed to this included the Law Society of Scotland and the Sheriffs' Association. Some of those who favoured it remarked that it would be very difficult to obtain sufficient evidence to satisfy a court of the need to rectify a home-made will. There are arguments both ways on this issue but we have come to the conclusion that it would be safer to confine rectification to cases where the will has been prepared by someone other than the testator and where, accordingly, there could be a comparison between the instructions and the will.

Conclusions 4.25 We think that a power to rectify wills which fail to give effect to the testator's instructions should be introduced. It should not extend to wills written by the testator himself. We can see no reason why the power should not be exercisable by either the Court of Session or the sheriff court.

4.26 So far as time limits are concerned we think that a normal limit of 6 months from confirmation would allow sufficient time for an application, while still providing protection against stale claims. There may, however, be special circumstances (eg the late discovery of documents which could not reasonably have been discovered earlier) where it would be reasonable to allow a late application and we suggest that, as in England, there should be power to permit this.

4.27 We also think that there should be express provision enabling the court to look at extrinsic evidence, and provision (again, as in England) protecting a trustee or executor who has acted in good faith on the basis of an unrectified will. So far as registration is concerned the position is similar to that arising on validation of an unauthenticated alteration and similar provision should be made.²

Recommendations 4.28 Our recommendations on rectification are as follows:

- 16(a) Provision should be made for the judicial rectification of a will prepared by someone other than the testator where the court is satisfied that the will is so expressed that it fails to give effect to the testator's instructions.**
- (b) The power to rectify should be exercisable by the Court of Session or by the sheriff court.**
- (c) An application for rectification should be possible only within 6 months from the date of confirmation of an executor, but the court should have power, on cause shown, to allow a later application.**
- (d) A court dealing with an application for rectification should be expressly empowered to consider extrinsic evidence.**
- (e) A trustee or executor should not be personally liable for distributing any property in good faith in accordance with a will which is later rectified.**

1. *Robertson v Fleming* (1861) 4 Macq. 167, followed reluctantly in *MacQueen v J M Hodge & Son* (1989) 29 GWD 1365.

2. See para 4.19 above and clause 13(6) of the draft Bill.

- (f) Provision should be made for a court order rectifying a will to be registrable in the Books of Council and Session or sheriff court books if the will is already registered there or if it is being registered there at the same time.
(Clause 13)

Effect of marriage

- Present law** 4.29 In Scotland marriage has no effect on a will. In England and Wales a testator's marriage results in the revocation of the will, unless it appears from the will that it was made in contemplation of marriage.¹ The English rule is followed in most Commonwealth jurisdictions, although it has been questioned.²
- The case for revocation by marriage** 4.30 In favour of a rule that marriage revokes a will (unless the will provides otherwise) it can be argued
- (a) that marriage is so important an event in relation to succession that it is likely in the vast majority of cases to destroy the whole basis on which a prior will was made
 - (b) that most married testators would wish their estates to devolve under the rules on intestacy rather than under the terms of a will made before marriage which they had inadvertently failed to alter or revoke, and
 - (c) that the spouse's legal share would be much less valuable than his or her rights on intestacy.
- The case against revocation by marriage** 4.31 The main argument against automatic revocation by marriage is that it could frustrate the intentions of a testator who assumed, reasonably enough, that his will stood until revoked by him. Nowadays second marriages are common and people entering into them would not necessarily wish provisions in favour of their children by an earlier marriage to be revoked. This argument is reinforced by the consideration that the surviving spouse has his or her claim for legal share. Admittedly the value of this claim would be less than the spouse's share on intestacy but at least its existence means that the spouse is not left unprovided for.
- Consultation** 4.32 We did not express any provisional preference in memorandum 70 but merely invited views.³ The response was mixed, some institutional consultees being themselves split on the issue, but the weight of opinion was against revocation by marriage.
- Conclusion** 4.33 As the arguments against change in the present Scottish rule are at least as persuasive as the arguments for change, and as consultation revealed a majority against change, we think that the safest course is to retain the present law. We do not therefore recommend that a will should be revoked by the testator's marriage.

Effect of divorce and nullity

- Present law** 4.34 Divorce has no automatic effect on a will in Scotland and it is a question of construction whether a bequest to the testator's spouse is conditional on him or her

1. The English rule is in s18 of the Wills Act 1837 (as substituted by the Administration of Justice Act 1982).

2. The rule has been considered by the Lord Chancellor's Law Reform Committee, *Report on the Making and Revocation of Wills* (1980) Cmnd 7902, Part III; The Queensland Law Reform Commission, *Report on the Law Relating to Succession* (1978); the Tasmanian Law Reform Commission, *Report on Reform in the Law of Wills* (1983); the Victorian Statute Law Revision Committee, *Report upon the proposals contained in the Wills (Interested Witnesses) Bill 1971* (1972); the New South Wales Law Reform Commission, *Report on Wills-Execution and Revocation* (1986) and Law Reform Commission of British Columbia, *Report on the Making and Revocation of Wills* (1981). All of these bodies recommended retention of the rule, although the Law Reform Commission of British Columbia was divided. In none of the jurisdictions involved does a spouse have a statutory legal share. The Uniform Probate Code (which does give the spouse the right to claim a statutory legal share) does not provide for revocation of a will by marriage.

3. Para 5.4.

being still the testator's spouse at the time of the testator's death.¹ In England and Wales and a number of other countries a testator's divorce, in effect, revokes provisions in favour of his or her spouse, unless the will provides otherwise. The other provisions of the will are not revoked. Properly drafted statutory provisions on this subject ensure that property forfeited by the divorced spouse passes as if that spouse had failed to survive the deceased.²

The case for revocation by divorce

4.35 The considerations here are not the same as in the case of revocation of a will by marriage. There is here no question of revoking the whole will, but only a question of revoking the provisions in favour of the testator's spouse. Usually, it may be supposed, a divorced testator would not wish his former spouse to continue to take under his will. Indeed in some cases the former spouse might be the last person the testator would wish to benefit. As the couple's assets will often have been divided between them on divorce, the result of allowing one to benefit under the will of the other may be simply an unintended bonus. The argument for revocation by divorce of provisions in favour of the former spouse is, therefore, that this is likely to give effect to the testator's intentions and to prevent unforeseen and unwanted results.

The case against revocation by divorce

4.36 The main argument against revocation by divorce of testamentary provisions in favour of the testator's spouse is that the testator may have intended them to stand in spite of the divorce. This seems unlikely, however, given that there would normally already have been a division of property on divorce.

Consultation

4.37 There was very strong support on consultation for a rule that a testator's divorce should revoke testamentary provisions in favour of the testator's spouse, unless the will provides otherwise. Those who supported this rule were also generally in favour of applying the same rule to any appointment of the former spouse as trustee, executor, tutor or curator.

Nullity of marriage

4.38 In memorandum 70 we suggested that a decree of declarator of nullity of marriage should have the same effect as divorce for this purpose. There was no dissent on consultation.

Conclusion

4.39 We think that divorce or a decree of declarator of nullity of marriage should, unless the will provides otherwise, revoke testamentary provisions by one of the spouses in favour of the other. The testamentary provisions subject to revocation by divorce should include any testamentary appointment of the spouse as a trustee, executor, curator, tutor or donee under a power of appointment. It should also include any testamentary provision conferring a power of appointment on the spouse. The best way of achieving the desired results would be to have a general rule that, for the purposes of the will, the divorced spouse should, except in so far as the will indicates that he or she is to benefit notwithstanding divorce, be deemed to have failed to survive the testator. The following examples show how such a provision would work.

Example 1

Mr Brown makes a will leaving his whole estate to "Mrs Agnes Brown, of 247 Main Street, Hilltown or, if she fails to survive me by five days, to [a named charity]". At the time of the will Agnes Brown is Mr Brown's wife. By the time of his death they are divorced, but he has forgotten to alter his will. She survives him for more than five days. The result of the rule recommended is that Agnes Brown is deemed to have failed to survive the testator for the purposes of the will, including the bequest to the charity. Accordingly, the charity will take the estate.³

1. See *Henderson's J F v Henderson* 1930 SLT 743; *Pirie's Trs v Pirie* 1962 SC 43; *Couper's J F v Valentine* 1976 SLT 83.

2. See eg the Uniform Probate Code s.2-508. Section 18A of the (English) Wills Act 1837 (inserted by the Administration of Justice Act 1982) is not properly drafted in this respect. See *Re Sinclair, deceased* [1985] 2 WLR 795 and memorandum 70 para 5.6.

3. This result would not be achieved if the Act simply said that the bequest to the spouse was revoked or lapsed. See *Re Sinclair, decd* [1985] 2 WLR 795.

Example 2

A testator leaves his whole estate to his wife in life and his children in fee. He dies shortly after being divorced, without having altered his will. The result of the rule recommended is that the ex-wife is deemed to have failed to survive the testator for the purposes of the will. Accordingly the life tenant does not take effect and the children take immediate possession of the fee.

Example 3

As part of a divorce settlement worked out between themselves without legal advice, a couple agree that the husband, who is much older than the wife, will keep a country cottage during his life but will leave it to the wife by will. Accordingly, before the divorce, he makes a will which explains that it is part of the arrangements made in connection with the anticipated divorce and leaves the cottage to the wife. Here there is a clear indication in the will that the ex-wife is to benefit notwithstanding the divorce and, under the rules we are recommending, she will be able to take the cottage.

Special destinations

4.40 It is common for spouses to take the title to their house in their joint names with a special destination to the survivor of them.¹ The effect under the present law, if the spouses are divorced and if one then dies without having evacuated the destination, is that the deceased's share of the house will pass to the former spouse. This can happen even where the parties may think they have resolved the question of ownership of the house at the time of the divorce.

Example

Mr and Mrs A take the title to their house in their joint names with a destination to the survivor. On divorce it is agreed that Mr A will transfer his half share of the house to Mrs A. He does so. Mrs A then dies. As nothing has been done about the special destination *her* original half share passes, in terms of the destination, to her former husband.

The unfortunate result in the above case could have been avoided if at the time of the divorce Mr and Mrs A had both disposed the house to Mrs A so that she became sole owner of it. Less common, but still possible under the existing law, is the case where a house is in the name of one spouse with a special destination to the other spouse on the owner's death.

4.41 The question for consideration is whether divorce or annulment of a marriage ought to revoke a special destination in favour of the spouse. There seems little doubt that it should do so in cases where the deceased spouse provided the purchase money for either the whole house or his or her half share. In such a case the house or the half-share is, in every sense, his or her own property and the special destination is just like a testamentary bequest to the other spouse. There is more difficulty, perhaps, about the situation where the surviving spouse (say, the husband) purchased the whole house and took the title in joint names with a survivorship clause. Why, it might be asked, should he not continue to receive the benefit of the survivorship destination even after a divorce? The answer, it is submitted, is that the surviving spouse has only himself to blame. If he had wished to retain the whole house he should not have given half to his wife. By giving her a half share, as many spouses do, he took the risk that he would not get it back. Moreover if the matter had been considered at the time of the divorce the position then would have been that each spouse had a half-share in the house. If the house had been sold each would have taken half the proceeds. The fact that the title survives divorce with a special destination still in it will often be the result of accident rather than design. There is no reason why the surviving spouse should be better off in that situation than he would have been if the house had been sold and the proceeds divided on divorce. We suggest, therefore, that divorce or annulment of a marriage should have the effect of revoking any special destination whereby on the death of one spouse property or his or her share of property would pass to the other spouse, unless the destination indicates that the

1. We deal more generally with special destinations in Part VI.

surviving spouse is to take notwithstanding the termination of the marriage by divorce or annulment.

4.42 A rule of revocation of certain special destinations on divorce or annulment would mean that in some cases the recorded or registered title to heritable property would not correspond to the true position. The title might say that the property belonged to A and B and the survivor whereas in fact it would belong to A and B without a survivorship destination. The spouses could correct the position at or after the time of the divorce by disposing to themselves in joint names without a survivorship clause or, in the case of registered land, by asking the Keeper to rectify the register by deleting the revoked survivorship clause. This, however, presupposes that they are properly advised of the legal position. The real difficulty arises if the parties are unaware of the effect of the special destination and do nothing about it until one of them dies. The survivor, in the case of a typical survivorship destination, will then appear to have the sole title but will own only half of the property. This, of course, is one of the unfortunate results of allowing special destinations (which are really concerned with succession) to appear in titles. It seems clear as a matter of policy that any loss resulting from the revocation of a special destination should fall on one or both of the parties who chose to complicate the title by inserting the special destination. It should not fall on a *bona fide* purchaser from, or heritable creditor of, a survivor who appears to have succeeded to the property, or part of it, under the destination. Nor should it fall on the Keeper of the Registers of Scotland. We think therefore that it should be made clear by legislation that the revocation of a special destination by divorce or annulment should not prejudice any person who acquires heritable property, or an interest in it,¹ in good faith and for value, from a person who, so far as the title to the property discloses, has succeeded to it or any share in it by virtue of the special destination. It should also be made clear that the Keeper of the Registers of Scotland is not liable to indemnify any person (such as the deceased spouse's executor) who suffers loss as a result of this rule. The effect of provisions on these lines is illustrated in the following examples.

Example 1

The title to a house (recorded in the Register of Sasines) is in the names of Mr and Mrs A and the survivor. Mr and Mrs A are later divorced. Mrs A continues to occupy the house but nothing is done about the title. Mr A dies. Mrs A, thinking she now owns the whole house, sells it to B who sees Mr A's death certificate but does not know of the divorce. Mr A's executor hears of the sale after the disposition in B's favour has been recorded.

The result of the proposed rule is that B has a good title. Mr A's executor can claim half the net proceeds of sale from Mrs A under the law on unjustified enrichment.²

Example 2

The facts are as in Example 1 except that the title is registered in the Land Register and Mr A's executor cannot recover from Mrs A because she has spent the proceeds of the house and had no other funds. The executor asks the Keeper to rectify the Register to show him as the owner of a half share. The Keeper refuses, as he is bound to do, because rectification would prejudice B, the new proprietor in possession.³ The executor then claims indemnification from the Keeper under section 12(1) of the Land Registration (Scotland) Act 1979 because of his refusal to rectify. This claim fails because of the new statutory rule excluding indemnity in such circumstances.

It is perhaps worth noting, before we leave the subject of special destinations, that problems of the type mentioned above should be rare. The former matrimonial home will usually be sold after separation or divorce and before the death of either spouse. If it is to be kept by one of the spouses the title will usually be, and should always be, properly corrected at the time of the divorce. It will be unusual for the house

1. Eg as a heritable creditor.

2. Mrs A has gained and Mr A's executor has lost, without legal justification or intention of donation. This is on the assumption that there is no fraud on Mrs A's part. If there is then Mr A's executor would have another ground of action.

3. Land Registration (Scotland) Act 1979, s9(3).

to continue to be held in the name of the two former spouses and the survivor by the time that one spouse dies. Even where this is the case any lawyer acting for the survivor or for the deceased's executor should realise, if the law is changed as we recommend, that the survivorship destination has been revoked by the divorce. Moreover any lawyer acting for a purchaser from an apparent surviving spouse would ask if there had been a divorce. Even if a sale by the survivor does take place in error it would be unusual for the proceeds to have been dissipated by the time the deceased spouse's executor learns of the position.

Effect of remarriage 4.43 In memorandum 70 we suggested that a provision revoked by divorce should be revived if the parties subsequently remarried each other.¹ Several consultees opposed this, on the ground that implied revival of a revoked provision was liable to lead to uncertainty and we do not pursue it. The problem, if it is a problem, is not likely to be of frequent occurrence.

Foreign divorces or annulments 4.44 The same rule should apply no matter where the divorce or annulment is obtained, provided it is recognised in Scotland.

Recommendations 4.45 We recommend that:

17(a) Divorce or annulment of marriage should have the effect of revoking

- (i) any testamentary provision made by one of the spouses in favour of the other (including a provision conferring a power of appointment on the other)
 - (ii) any testamentary appointment by one spouse of the other spouse as a trustee, executor, curator, tutor or donee of a power of appointment
 - (iii) any statutory nomination by one spouse of the other as the person entitled to receive property (such as savings certificates) on his death
 - (iv) any special destination whereby on the death of one spouse the other would succeed to any of that spouse's property
- except in so far as the will, nomination or destination indicates that the surviving spouse is to benefit notwithstanding the termination of the marriage by divorce or annulment.
- (b) The effect of a revocation by divorce or annulment should be that the former spouse is deemed, for the purposes of the will or nomination or the succession to the deceased spouse's property or part of the property under the special destination, to have failed to survive the deceased spouse.
 - (c) These rules should apply to British divorces or annulments and to foreign divorces or annulments recognised in Scotland.
 - (d) The revocation of a special destination by divorce or annulment should not prejudice any person who acquires property, or an interest in it, in good faith and for value, from a person who, so far as the title discloses, has succeeded to that property or interest by virtue of the special destination.
 - (e) The Keeper of the Registers of Scotland should not be liable to indemnify any person who suffers loss as a result of the protection afforded by the preceding paragraph.

(Clause 14)

Effect of birth of child

Present law: *conditio si testator* 4.46 Under the present law of Scotland the birth of a child to the testator after the date of a will gives that child the right to challenge the will by invoking the so-called *conditio si testator sine liberis decesserit*.² This is a rule whereby a child born after

1. Para 5.4.

2. *Elder's Trs v Elder* (1895) 21 R 704, 22 R 505; *Nicolson v Nicolson's Tutrix* 1922 SC 649; *Stevenson's Trs v Stevenson* 1932 SC 657.

the date of a will made by his or her parent can apply to a court to have the will “treated as revoked” on the ground that there was no provision for him in it and no indication that the testator intended the will to stand notwithstanding his birth. The question for consideration here is whether there should continue to be a rule to this effect.

4.47 The *conditio si testator sine liberis decesserit* appears to have been introduced into Scots law by the Court of Session in the eighteenth century.¹ There used to be a similar rule in English law but it was abolished by the Wills Act of 1837.² There is, so far as we can determine, no corresponding rule in continental European laws.³ The Uniform Probate Code contains a provision to the effect that a child born after the date of the will, who has not been provided for in the will, receives the share which he would have been entitled to on intestacy: this does not apply, however, if it appears from the will that the omission was intentional, or if when the will was executed the testator had a child and nonetheless left substantially all his estate to the other parent of the omitted child, or if the testator had made provision for the child in lieu of a testamentary provision.⁴ It should be borne in mind, however, that this provision of the Uniform Probate Code is in the context of a system which does not provide legal share or discretionary family provision for children.

Consultation 4.48 In memorandum 70 we asked whether the *conditio si testator* should be retained as part of the law.⁵ We noted that an omitted child could claim legal share. We also noted that where there was a surviving spouse the *conditio* was of little value, because in most cases the revocation of the will would lead to the whole estate passing to the spouse on intestacy. We also pointed out that in cases not involving a surviving spouse the operation of the *conditio* could produce unfortunate results. A man, for example, might have left everything to the woman with whom he had lived as husband and wife for many years. The birth of a child, followed by the man’s sudden death, would result in the application of the *conditio* and an intestacy under which the deceased’s whole estate would go to the child. This, it may be supposed, would probably not have been the testator’s wish. It is arguable that in this type of case a better result would be achieved by letting the will stand and allowing the child to claim legal share. For these reasons we doubted whether the *conditio si testator* was worth preserving. Most consultees, including all the institutional consultees who commented on this issue, supported abolition of the *conditio si testator*.

Recommendation 4.49 We recommend that:

18. The rule known as the *conditio si testator sine liberis decesserit* (whereby a will may in certain circumstances be held to be revoked by the subsequent birth of a child to the testator) should be abolished.

(Clause 15)

Legatee predeceasing leaving issue

Present law: *conditio si institutus*

4.50 Where a testator leaves a legacy in the nature of a family provision to a child, grandchild or other descendant of his (or where he leaves such a legacy to a nephew or niece, in relation to whom he has placed himself *in loco parentis*) and where the legatee dies before the date of vesting leaving issue, the issue of the legatee take the share he or she would have taken unless the will contains an express or clearly implied indication to the contrary.⁶ This rule is known as the *conditio si institutus sine liberis*

1. See *Yule v Yule* (1758) Mor 6400; *Watt v Jervie* (1760) Mor 6401.

2. For the pre-1837 law see *Johnston v Johnston* 1 Phil 447 (1817) 161 Eng Rep 1039. The Wills Act 1837 ss18 and 19 provide that a will is revoked by marriage but not by any presumption of intention on the ground of any other alteration in circumstances.

3. The French Civil Code, for example, provides only for *express* revocation of wills. See art 1035.

4. S2-302.

5. Para 5.11.

6. See *Hall v Hall* (1888) 18 R 690; *Knox's Ex v Knox* 1941 SC 532; *Sinclair v Sinclair's Trs* 1942 SC 362 (rule does not apply to bequests to stepchildren); *Thomson's Trs Petrs* 1963 SC 141 (rule does not apply to non-testamentary deeds); *McGregor's Trs v Gray* 1969 SLT 355.

decesserit. In essence it involves reading into the will words such as “whom failing his issue”.

4.51 Many other jurisdictions have a similar rule, although the details vary. In England and Wales, for example, the rule applies only to bequests to the testator’s children, grandchildren or other descendants: it does not apply to bequests to nephews or nieces.¹ In South Africa the rule applies only in the case of bequests to children of the testator: it does not apply to bequests to remoter descendants.² Under the Uniform Probate Code (United States of America) the rule applies to a bequest to a grandparent or lineal descendant of a grandparent of the testator.³

Case for allowing issue to take 4.52 The argument for retaining the *conditio* is that it is likely to give effect to the wishes of testators. It is based on the assumption that where a testator in a bequest to a close relative fails to insert some such words as “whom failing his issue” this is due to an oversight or a failure to consider the possibility that the legatee might die before the date of vesting leaving issue.

Case against allowing issue to take 4.53 The argument against retaining the *conditio* is that testators should be taken as meaning what they say. If a testator wishes to insert “whom failing his issue” he can readily do so. To read into wills words which are not there can lead to complications, confusion and unintended results. It can be difficult to decide whether a bequest is of the type to which the *conditio* applies and whether the will does contain a sufficient indication that the issue are not to take.⁴ It can be particularly difficult to decide whether the special requirements for the application of the *conditio* in relation to nephews and nieces are satisfied.⁵

Consultation 4.54 In memorandum 71 we expressed the view that the advantages of retaining the *conditio*, with certain modifications to make it easier to apply, outweighed the disadvantages.⁶ Almost all consultees agreed with this view.

Conclusion 4.55 We conclude that the rule known as the *conditio si institutus sine liberis decesserit* should be retained, though not necessarily under that name⁷ and not necessarily without modifications.⁸

Scope of the rule 4.56 The courts have taken the view that the *conditio si institutus* is an artificial doctrine which should not be extended.⁹ Indeed the limited extension to nephews and nieces has given rise to a good deal of difficulty and litigation. It has clearly been regretted by a number of judges landed with its consequences.¹⁰ One option would be to restrict the *conditio* to bequests to the testator’s descendants, thus restoring it to its original scope.

4.57 Another option would be to extend the *conditio* in various ways—eg to bequests to step-children, collaterals, parents or grandparents. Although we rather favoured a modest extension of the scope of the *conditio* in memorandum 71, and although there was support from consultees for some extension, we have come to the conclusion, after reconsideration, that it is very difficult to justify drawing a line at any point beyond the testator’s own descendants. The special position of descendants of the deceased, and the issue of predeceasing descendants, is recognised for the purposes of legal rights (and we are recommending that this should continue in relation to legal shares) and it seems reasonable to read into a will a conditional institution of the issue of descendants. It is not so reasonable, and indeed is probably not justifiable, to read

1. Wills Act 1837, s33 as amended by Administration of Justice Act 1982, s19.

2. General Law Amendment Act 1952, s24.

3. S2-605.

4. See eg *Devlin’s Trs v Breen* 1945 SC (HL) 27.

5. See eg *Knox’s Ex v Knox* 1941 SC 532.

6. Para 4.9.

7. See para 4.66 below and clause 17 of the draft Bill.

8. We consider possible modifications below.

9. *Hall v Hall* (1891) 18 R 690.

10. See eg L P Normand in *Knox’s Ex v Knox* 1941 SC 532 at p535—“it may be questioned whether the extension was justified either in principle or by expediency”.

such a conditional institution into bequests to grand-parents, parents, uncles, aunts, nephews, nieces or cousins. A woman who leaves a bequest to her mother would not usually intend to benefit her brother should her mother have predeceased her. On intestacy, ascendants succeed as individuals and not as representatives of a line and there is something to be said for applying the same approach to bequests. A bequest to a cousin, uncle or aunt, or brother or sister is as likely to be personal as to be made to the legatee as a representative of a family line. Probably the same can be said of a bequest to a nephew or niece. The original extension of the *conditio* to nephews and nieces by the courts was confined to cases where the testator was *in loco parentis* to them but the obvious difficulties inherent in allowing extrinsic evidence of this led to the requirement being held to be satisfied if, from the terms of the will, the provision appeared to be the type of provision a parent would have made for his or her children.¹ Even this test is clearly a vague one and it is not easy to see exactly what it means.² It is not therefore surprising that in later cases the courts have proceeded on the basis that there is a presumption that the testator has placed himself *in loco parentis* towards a legatee who is a nephew or niece unless the will indicates that the bequest was made from personal favour.³ The fundamental difficulty is that to require extrinsic evidence that a bequest to a nephew or niece was made as a "family" provision by someone who had placed himself *in loco parentis* would present obvious difficulties and could lead to a great deal of very vague and inconclusive evidence, while to apply the *conditio* to nephews and nieces without any such requirement is likely to result, in some cases, in reading into the will words which the testator would not have wished to see included.

4.58 The question whether the *conditio* should be applied to bequests to step-children of the deceased proved controversial. Consultees were divided both on the question whether step-children should be included at all, and on the question whether, if they were, the *conditio* should apply only if they had been accepted by the testator into his family. The difficulty here is that the relationship between a testator and a step-child may vary from the case where the step-child was an infant at the date of the marriage and was brought up as a child of the testator in every way, to the case where the step-child was an independent adult living away from home at the time of the marriage. As in the case of a nephew, it would be undesirable to admit extrinsic evidence as to whether the testator was *in loco parentis* and the bequest was in the nature of a "family" provision and equally undesirable to apply the *conditio* to all bequests to step-children as a matter of course. Other questions in relation to step-children are whether a bequest to a descendant of a step-child, or a bequest to a step-child of a child, or a step-child of a step-child should be included. In relation to all cases involving step-children it would also be necessary to ask whether a former step-child should be regarded as a step-child.

4.59 Although our initial inclination, as we have said, was to favour a modest extension of the *conditio*, the more we have thought about this issue the more firmly have we come to the conclusion that the disadvantages and difficulties of applying the rule beyond bequests to descendants outweigh any advantages.

4.60 In memorandum 71 we noted that in British Columbia the spouse of a predeceasing legatee could in certain cases take the legacy by virtue of the rule corresponding to the *conditio si institutus*.⁴ We did not favour such a rule as we thought it was unlikely to give effect to the intentions of most testators. Most consultees agreed and we accordingly make no recommendation on this point.

4.61 In some jurisdictions the issue of a legatee who was, unknown to the testator, already dead at the date of execution of the will may take the legacy by virtue of a rule corresponding to the *conditio*.⁵ In Scotland the *conditio* applies only if the

1. *Bogie's Trs v Christie* (1882) 9 R 453.

2. See *Waddell's Trs v Waddell* (1896) 24 R 189 per Lord McLaren at pp196-197.

3. *Knox's Ex v Knox* 1941 SC 532. See also Scott, "Conditio si Institutus sine Liberis Decesserit" 1958 SLT (News) 229.

4. Wills Act 1979, s22(2).

5. See eg the Uniform Probate Code s2-605.

legatee was alive at the date of execution of the will.¹ We suggested in memorandum 71 that the Scottish rule should continue. Most consultees agreed. There are arguments both ways on this issue. We think, however, that in most cases a testator leaving a bequest to a child or other descendant could be expected to know whether the beneficiary was alive or, if there was uncertainty, to make specific provision for the possibility of predecease. It would be highly artificial to apply the *conditio* in a case where the testator knew the legatee was already dead. A testator who leaves the residue of his estate to his children could not reasonably be assumed to wish to benefit the issue of a child who, to his knowledge, was already dead. On the other hand it could be difficult, perhaps years after the date of the will, to establish the state of the testator's knowledge at that time. Given that the problem is likely to be of infrequent occurrence, and that almost all consultees favour retaining the existing rule, we do not propose to recommend any change on this point. A decree of declarator of death under the Presumption of Death (Scotland) Act 1977 has the result that, unless the decree is recalled, the person is treated as dead for all purposes including "the acquisition of rights to or in property belonging to any person".² Accordingly no special provision needs to be made for the effect of declarators under the Act.

4.62 One of the difficulties in applying the *conditio si institutus* is in deciding whether a will sufficiently indicates an intention that the issue should not take the place of the deceased legatee. Somewhat surprisingly, it has been held that the *conditio* can apply even if the bequest contains a survivorship clause or a provision that someone else is to take the legacy in the event of the legatee's predecease.³ In such a case the testator has made express provision for the event of the legatee's predecease and it seems perverse to replace his express provision by a deemed destination to issue. In memorandum 71 we asked whether the *conditio* should apply unless expressly disapplied or whether it ought to apply unless the will contained an express or clearly implied intention that the issue were not to take.⁴ We also asked specifically whether a survivorship clause or destination over should be regarded as disappling the *conditio*.⁵ There was a good deal of support on consultation for applying the *conditio* unless there was an express declaration in the will that it should not apply. We think, however, that this could lead to results which a testator, particularly a testator acting without professional legal advice, would not have intended. A testator would often not know of the *conditio*, far less of a need to disapply it expressly. On the question whether an express survivorship clause or destination over should disapply the *conditio*, opinion was fairly evenly divided. The argument for disappling the *conditio* is, as we have seen, that the testator has made express provision for the share to go to someone on the legatee's predecease and, this being so, there is no reason to frustrate his intentions by reading in a deemed destination to issue. The counter argument is that the testator may not have envisaged the legatee's predecease survived by issue. This, however, seems rather speculative and unconvincing. We think that to deny effect to the testator's express provision for the event of a legatee's predecease is likely to cause confusion and to set a trap in the administration of estates.

4.63 We have considered whether there ought to be any restriction on the type of legacy to which the *conditio* applies. Its most natural application is to a bequest of a share of residue and its least natural application is to a bequest of a specific item of property.⁶ However, it is not unknown for a testator to leave a large specific legacy instead of a share of residue and we think it would be arbitrary and unsatisfactory to distinguish between different types of legacy.

1. *Barr v Campbell* 1925 SC 317. The *conditio* applies, however, where the legatee was alive at the date of the will but died before the date of a codicil confirming the will: *Miller's Trs v Miller* 1958 SC 125.

2. S3(1).

3. *Dixon v Dixon* (1841) II Rob App 1; *Devlin's Trs v Breen* 1945 SC (HL) 27.

4. Paras 4.20 and 4.21.

5. Para 4.21.

6. In *Wauchope* (1882) 10 R 441 and *McAlpine* (1883) 10 R 837 it was held that the *conditio* did not apply to bequests of corporeal moveables.

4.64 At present the issue of a predeceasing beneficiary, who take by virtue of the *conditio*, take only the beneficiary's original share, and not the share he or she would have taken if he or she had survived the date of vesting.¹

Example

A testator leaves his estate to his three sons A, B and C. There is no express survivorship clause. A predeceases the testator leaving a daughter. B predeceases without issue. C survives. If A had survived he would have shared the estate equally with C, the other surviving child. However, the rule mentioned in the text means that A's daughter does not take the half share he would have received on survival but only the one third share originally left to him in the will.

In memorandum 71 we suggested that this rule was difficult to justify and that the issue taking under the *conditio* should take the share that the beneficiary would have taken on survival. This was accepted by all who commented. To deal with the fact that more than one legatee may die before the date of vesting leaving issue who take by virtue of the *conditio*, the rule should be that the issue of a predeceasing legatee take the share that the legatee would have taken if he and any other legatee whose issue take under the *conditio* had survived the date of vesting. So, in the above example, if B had predeceased the testator leaving issue the estate would have been divided into three, the issue of A and B respectively taking the shares their parents would have taken had both survived.

Recommendations 4.65 We recommend that:

- 19(a) **There should continue to be a rule whereby, if a legatee within a certain class dies after the date of the will but before the date of vesting, his or her issue take the legacy unless the will expressly, or by clear implication, provides otherwise.**
- (b) **The rule should be confined to bequests to direct descendants of the testator.**
- (c) **The will should be regarded as providing otherwise if the bequest contains an express survivorship clause or destination over.**
- (d) **Where the rule applies, the issue of the predeceasing beneficiary should take the share that the beneficiary would have taken if he (and any other predeceasing beneficiary whose issue take by virtue of the rule) had survived the date of vesting.**

(Clause 17)

4.66 The draft Bill appended to this report adopts the technique of abolishing the *conditio si institutus* expressly and replacing it with new statutory rules.² The reason for this is to make it clear that a fresh start is being made and that cases on the *conditio* are irrelevant to an interpretation of the new statutory rules.

Revival of revoked wills

Present law 4.67 The present law is that if a will which revokes a previous will is itself revoked, then the previous will revives³ unless, possibly, it can be proved by extrinsic evidence that the earlier will was not intended by the testator to have any continuing effect as a potential testamentary document.⁴

Criticism of present law 4.68 The law on this point does not seem satisfactory.⁵ Indeed it is quite likely to produce effects which would not have been intended by the testator. The operation

1. *Young v Robertson* (1862) 4 Macq 509; *Neville v Shepherd* (1895) 23 R 351.

2. Clause 17.

3. *Bruce's J F v Lord Advocate* 1969 SC 296; *Scott's J F v Johnston* 1971 SLT (Notes) 41.

4. *Ferguson v Russell's Trs* 1919 SC 80 per Lord Sands at p84. Lord Sands gave the examples of a testator who had given his solicitor instructions to destroy the old will (which instructions had not been carried out) or a testator who had given the old will "to an autograph-hunting friend because some great celebrity was one of the instrumentary witnesses."

5. See Meston "Revival by Revocation of the Revoking Will" 1974 SLT (News) 153.

of the present rule that the revocation of a revocation revives the revoked will can be illustrated by two cases.

1. In *Bruce's Judicial Factor v Lord Advocate*¹ the testator executed a will in 1945. In 1949 he executed a new will which contained a clause revoking all previous testamentary writings. He did not expressly instruct his solicitors to destroy the 1945 will and they retained it. The 1949 will was proved to have been in the testator's custody from 1955 and was not proved to have left his custody. When the testator died in 1961 the 1949 will could not be found and was therefore presumed to have been destroyed by him with the intention of revoking it.² In these circumstances it was held that the 1945 will took effect.
2. In *Scott's Judicial Factor v Johnston*³ the testatrix executed a testamentary writing in 1963 ("the 1963 will"). In 1964 she executed another ("the 1964 will") which expressly revoked all previous testamentary writings. Her solicitor, however, retained the 1963 will. On her death there was found a subsequent signed holograph writing which said

"I, Marion A Scott cancel completely the will drawn up by Mr Gilruth and signed by me."

It was agreed that this revoked the 1964 will and it was held that the result was that the 1963 will regulated the succession.

The way in which the present law operates in this kind of case does not seem sensible. A person who expressly revokes all previous wills would, it may be supposed, normally assume that they were dead and finished with. He would not assume that they would remain in his solicitor's strong room in a state of suspended animation ready to spring into life at any time. One effect of the present law is that if a testator wishes to ensure that a prior will in the custody of his solicitor is revoked once and for all he must act with extraordinary foresight and decisiveness. He must either expressly instruct the solicitor to destroy the revoked will (which many people would not think of doing) or make sure that some clear evidence is preserved of his intention that the will should have no "suspended animation" or "potential effect"⁴ (which hardly anyone would ever think of doing).

4.69 There is one theoretical argument which has to be dealt with in relation to the revival rule. It featured prominently in the case of *Bruce's Judicial Factor*⁵ and is to the effect that as a will speaks from death, so a revocation in a will speaks from death. Therefore such a revocation never has any effect if the revoking will is itself revoked before death. While this is true of so-called implied revocation by later inconsistent testamentary provisions, it is not true of all express revocations. An express revocation of a will need not be in a subsequent will. It could be in a separate document standing on its own and clearly intended to have immediate effect. Moreover an express revocation clause in a will may be severable⁶ and may be intended to have immediate effect. The testator who says "I hereby revoke" probably means "I now hereby revoke". He cannot reasonably mean "I, as from the moment of my death, revoke all testamentary writings executed prior to my death". He is unlikely to mean "I, as from the moment of my death, revoke all testamentary writings executed prior to the date on this document". There is no rule against immediate revocation. A testator, after all, can revoke his will immediately by destroying it. This being so, it must be a matter of construction whether immediate revocation is intended. The natural construction of the words "I hereby revoke" is that they are intended to bring about immediate revocation.

Comparative law

4.70 In English law a revoked will is not revived by the revocation of the revoking instrument. The Wills Act 1837 provides that

1. 1969 SC 296.

2. See *Clyde v Clyde* 1958 SC 343.

3. 1971 SLT (Notes) 41.

4. Terms used to describe the state of a revoked will in *Bruce's J F v Lord Advocate* 1969 SC 296 at pp305 and 311.

5. See 1969 SC 296 at pp305 and 307.

6. Cf *Leith v Leith* (1863) 1 M 949 at p955.

“No will or codicil, or any part thereof, which shall be in any manner revoked, shall be revived otherwise than by the re-execution thereof, or by a codicil—executed in manner hereinbefore required, and showing an intention to revive the same . . .”¹

The Irish Succession Act 1965 retains the same rule.² The English and Irish rule is, of course, the exact opposite of the general rule in Scotland.

4.71 In French law the general rule is that the earlier will revives when an express revocation of it is retracted.³ Nevertheless it is regarded as a question of intention, to be decided on the circumstances of the case, whether in revoking a second will (which revoked an earlier will) the testator wished to revive the first or to allow the rules of intestate succession to apply.⁴ The distinction which is drawn here is between a retraction of a simple express revocation standing on its own (which could have no other purpose than to revive the earlier will) and a revocation of a will containing the revocation (which could be intended either to revive the earlier will or to leave both wills revoked).

4.72 In West Germany the rule is that

“If the revocation by will of a testamentary disposition is revoked, in case of doubt the disposition is valid as if it had not been revoked.”⁵

This refers to the case where the first revocation is express. If a will which impliedly revoked an earlier will by inconsistency is revoked then

“the first will becomes valid to the same extent as if it had not been revoked.”⁶

4.73 There is a particularly interesting solution in the Uniform Probate Code. Section 2-509 provides as follows

“(a) If a second will which, had it remained effective at death, would have revoked the first will in whole or in part, is thereafter revoked by acts [eg destroying, tearing or obliterating], the first will is revoked in whole or in part unless it is evident from the circumstances of the revocation of the second will or from testator’s contemporary or subsequent declarations that he intended the first will to take effect as executed.

(b) If a second will, which had it remained effective at death, would have revoked the first will in whole or in part, is thereafter revoked by a third will, the first will is revoked in whole or in part, except to the extent it appears from the terms of the third will that the testator intended the first will to take effect.”

These rules, although more flexible than the English and Irish rule, would still have led to different results in the two Scottish cases summarised above.

Consultation

4.74 In memorandum 70 we reached the provisional conclusion that there should be either a rule of non-revival or a presumption of non-revival, in all cases where a will was expressly revoked.⁷ We thought that a different rule might be justified in the case of so-called implied revocation by the execution of a later inconsistent will.⁸ Here the intention to effect immediate revocation is by no means clear and it is arguable that on the revocation of the later will the earlier will simply continues to govern the situation. On consultation most consultees, in the interests of certainty, favoured a rule of non-revival rather than a presumption. Only one consultee favoured the existing rule that an expressly revoked will revives on the revocation of the revoking will. Most consultees thought that the same rules should apply where the second will impliedly revoked the first.

1. S22.

2. S87.

3. Dalloz, *Nouveau Repertoire*, “Legs” No 151.

4. *Ibid.*

5. BGB s2257 (transl by Forrester, Goren & Ilgen).

6. *Ibid* s2258.

7. Para 6.20.

8. *Ibid.* We say “so-called” because it is arguable that the rule is really that the two wills are read together and the later one allowed to prevail in so far as there is inconsistency. See *Kirkpatrick’s Trs v Kirkpatrick* (1874) 1 R (HL) 37 at pp44 and 48.

Recommendations

4.75 We agree with consultees that a rule of non-revival of an expressly revoked will would be simpler and more certain than a presumption. We think, however, that it should be possible for a testator to revive a revoked will by re-executing it. That is just a quick way of making a new will in the same terms as the old. If this is recognised then the same result ought to follow in the case (which we imagine would be unusual in practice) where a testator executes a separate document saying merely that the earlier will is revived. Again that is just a quick way of making a new will in the same terms as the old. It may be that both these cases could be held by a court to involve new wills, but it seems preferable to make express provision for them rather than leave room for doubt.

4.76 We have had more difficulty with the case where the second will does not expressly revoke the first but is so inconsistent with it that the two cannot both be given effect. Logically, this is a different situation. The first will is merely displaced to the extent of any inconsistency and, as a matter of principle, ought to receive effect once the inconsistency is removed by the revocation of the second will.¹ We think that it would be safer and more in accordance with principle to confine a rule of non-revival to cases where the first will had been expressly revoked. We therefore recommend that:

20. A will which has been expressly revoked should not revive unless the testator re-executes it or executes another document which expressly revives it.

(Clause 16)

Conditional revocation

4.77 Under the present law a revocation of a will may be expressly or impliedly conditional on something happening or on some state of affairs existing. We analysed the law on this subject in some detail in memorandum 70 and concluded that, in general, it was sensible and satisfactory. The only aspect of it which we thought was open to criticism was a suggestion by Lord McLaren in one case that there was a rule that where words in a will were scored out and others inserted in their place, the cancellation of the original words was conditional on the substituted words taking effect.² On consultation there was complete agreement with our view that the law on conditional revocation was generally satisfactory. Some consultees thought, however, that it should be made clear that there was no absolute rule that the deletion of words in a will was always conditional on substituted words taking effect. Others, including the Faculty of Advocates, thought that there was no need for even this limited change. As the problems caused by deletions and substitutions would be greatly diminished if, as we have recommended,³ unauthenticated alterations could be given effect if proved to have been made by the testator with the requisite intent, we have decided to make no recommendations for change in the law on conditional revocation.

Making a will for an incapax

4.78 In Scotland no one has power to make a will for a person who lacks testamentary capacity. Indeed, as we pointed out in memorandum 70,⁴ the idea that someone else can make a will for anyone seems absurd, given that a will is, by definition, an expression of the will of the testator. What such a power would really be would be a power to change the ordinary rules of succession, testate or intestate, which would otherwise apply on the death of the *incapax*. In England and Wales the Court of Protection has power to direct the making of a will for a mentally incapable person.⁵

1. See *Leith v Leith* (1863) 1 M 949 per LJC Inglis at p955; *Kirkpatrick's Trs v Kirkpatrick* (1874) 1 R (HL) 37 at pp44 and 48; *Nicolson v Nicolson's Trs* 1922 SLT 473.

2. *Pattison's Trs v University of Edinburgh* (1888) 16 R 73 at p77.

3. Para 4.20 above. The difficulty in the present law is that the deletion may be effective even if not signed or initialled but the substitution must be signed or initialled. Under our recommendations both would be effective if proved to have been made by the testator with the requisite intent.

4. Para 4.1.

5. Mental Health Act 1983, ss93-97.

4.79 In memorandum 70 we set out arguments for and against enabling a court to authorise a judicial factor or *curator bonis* to make a will for an *incapax*. We gave examples of cases where such a power might be thought to be useful but pointed out that, in some of these cases, the same results could be achieved in other ways, such as by a deed of family arrangement, while in other cases the desirability of altering the succession on the basis of speculation seemed very doubtful. We expressed no concluded view but invited comments.¹

4.80 We expected opinion to be fairly evenly divided on this question as it seemed to us that there were arguments both ways. Although the arguments of principle seemed to us to be rather against a power to make a will for an *incapax*, we were aware that the power had apparently been found useful in England and Wales. In the event the results of consultation were overwhelmingly against the introduction of any such power. Those opposed included the Sheriff's Association, the Faculty of Advocates, the Law Society of Scotland, the Scottish Law Agents' Society, the Scottish Society for the Mentally Handicapped, the Committee of Scottish Clearing Bankers and a number of individual legal practitioners and members of the public. A consultant psychiatrist expressed the fear that a power to make a will for an *incapax* would lead to more pressure on the medical profession to pronounce patients incapable so that the succession to their estates might be altered. Some consultees thought there might be a case for a power to alter the will of an *incapax* who had been divorced, on the ground that the testator would presumably not have wished to continue to benefit his or her former spouse. That situation would, however, be dealt with directly by our recommendation that divorce should revoke provisions in favour of the former spouse. In these circumstances we do not recommend the introduction of a power to make a will for an *incapax*.

Meaning of "heirs" in private documents

4.81 When the Succession (Scotland) Act 1964 abolished the distinction between heritage and moveables for the purposes of intestate succession a doubt was created as to the meaning of terms such as "heir" or "heirs" or "heir-at-law" in pre-1964 documents. The Act provided that references in any enactment to the heir-at-law of a deceased person in relation to any heritable property should be construed as references to the persons who by virtue of the Act were entitled to succeed on intestacy.² It also provided that references in general terms in any enactment to the heirs of a deceased person should include (a) the persons entitled under the Act to succeed on intestacy to any part of the deceased's estate and (b) so far as necessary for the purposes of the part of the Act dealing with administration and the winding up of estates, the executor of the deceased.³ The 1964 Act contained no rules for the construction of such terms in private documents, no doubt on the view that each such document would require to be construed according to its own terms and that it would be dangerous and unprincipled to assign meanings retrospectively. This gave rise to a problem, but not an insuperable one. If a testator, who died before the 1964 Act came into force, left heritable property to X in liferent and X's heirs in fee, did X's heirs fall to be ascertained under the pre-1964 law or under the law in force at the time of X's death? Case law suggested that, in the absence of any special factors or guidance from the other terms of the document in question, the latter construction was correct.⁴

"No man can have an heir until he is dead, and it can never be ascertained who is to be a man's heir until he dies."⁵

Nonetheless, it was suggested to us when we were preparing our consultative memoranda on succession law that it would be advisable to clear up any doubt by a statutory

1. Para 4.5.

2. Sch 2 para 1.

3. Sch 2 para 2.

4. See Meston, "Bequests to 'Heirs'", 1974 SLT (News) 109.

5. *Black v Mason* (1881) 8 R 497 at p500. See also *Inglis v Inglis* (1869) 7 M 435; *Ferguson v Ferguson* (1875) 2 R 627; *Grani's Trs v Crawford's Trs* 1949 SLT 374; McLaren, *Wills and Succession*, Vol II p757.

provision. We accordingly sought views in memorandum 71 as to whether it would be necessary or desirable to provide by statute that a reference in a private writing to a person's heirs should, in the absence of a contrary indication in the deed, be taken as a reference to those who would be entitled to succeed to the person on intestacy under the laws applicable at the time when the succession opened to the heirs.¹

4.82 Although a number of those who commented on the question thought that some clarification would be desirable there was no great enthusiasm for legislation on this point. The Faculty of Advocates was not satisfied that there was serious doubt and did not consider that any further clarification was necessary. Nor was there complete agreement as to the desirable solution. One suggestion was that, if the legislation were introduced, a distinction ought to be drawn between testamentary and other documents.

4.83 We left this question open in memorandum 71 and consultation does not convince us that legislation is required. The lack of any provision for private deeds in the 1964 Act does not seem to have given rise to insuperable problems, even although it altered fundamentally the meaning of heirs in relation to heritable property. In general it is dangerous to assign meanings retrospectively to terms used in private deeds. The result could easily be a distortion of what the granter of the document really intended. So far as future deeds are concerned it would be possible to assign a meaning to "heirs" but we are not satisfied that this is necessary or desirable. The term is just one of many terms which might be used in a private deed. We have decided not to recommend any legislation on the meaning of "heirs" in private documents.

Mutual wills

4.84 In memorandum 71 we examined the law on mutual wills. The main difficulty in relation to such a will is in knowing whether or not it is contractual. If it is not, then the position is just as if there are two wills in one document. The surviving testator is free to revoke his part of the will at any time. If, however, the will is regarded as contractual neither testator is free to revoke his part unilaterally.² It can be very difficult to decide on which side of the line a will falls. The problems which can be caused by mutual wills have led to a decline in their use and we understand that they are now unusual. Our preliminary view was that there was no need for any change in the law on mutual wills. This was generally agreed on consultation and we accordingly make no recommendation on this point.

1. Para 4.2. The date when the succession opened would not necessarily be the date of the person's death. See eg *Macdonald's Trs v Macdonald* 1974 SC 23.
2. *Croll's Trs v Alexander* (1895) 22 R 677 at p681; *Hanlon's Ex v Baird* 1945 SLT 304.

Part V Survivorship

Present law

5.1 The first condition which must be satisfied before anyone can inherit is that he must survive the deceased. Under the present law survival for a mere instant suffices for purposes of intestate succession and legal rights. In cases of testate succession survival for a mere instant suffices unless the will provides otherwise. It is quite common, however, for wills to provide that a legatee must survive the testator for a specified number of days before being entitled to the bequest.¹ The present law contains certain presumptions of survivorship designed to resolve the difficulties which may arise when several people who are potentially entitled to succeed to each other are killed in a common calamity. The general presumption is that a younger person is presumed to survive an older person, but this does not apply as between husband and wife (where neither is presumed to have survived the other).²

Survival for a specified period

5.2 In memorandum 71 we suggested that there should be a general requirement of survival for a specified number of days for the purposes of intestate succession, legal rights and, unless the will provided otherwise, testate succession.³ We thought that most people would be unlikely to wish their estate to pass to someone, or into the estate of someone, who died within a few days after they did. We noted that some legal systems required a beneficiary to survive for a specified period, such as five days, before inheriting under a will or on intestacy. In the United States of America, for example, Section 2-104 of the Uniform Probate Code (which has been adopted in some 14 States) provides that any person who fails to survive the deceased by 120 hours is deemed to have predeceased the deceased for the purposes of intestate succession. Section 2-601 contains a similar rule for testate succession. It provides that:

“A devisee who does not survive the testator by 120 hours is treated as if he predeceased the testator, unless the will of decedent contains some language dealing explicitly with simultaneous deaths or deaths in a common disaster, or requiring that the devisee survive the testator or survive the testator for a stated period in order to take under the will.”

5.3 The proposal that a person who failed to survive the deceased for a specified period should be treated as having predeceased the deceased for succession purposes was generally welcomed on consultation. So far as the period is concerned, a number of consultees favoured a period of 30 days. Others favoured a shorter period, such as 2 days, on the view that the main utility of such a provision would be in removing the need for an inquiry into the precise order of death in cases of common calamity. As the required period would apply generally, and as it would be a new rule, we think that it would be wiser to begin with a short period which few, if any, testators would wish to shorten still further. A short period would minimise any problems which

1. The CRU research found that about 8% of testators included such a provision. The period of survivance required was usually one month. CRU report para 5.7.

2. Succession (Scotland) Act 1964, s31(1). There is also an exception for the case where the elder person has left a bequest to the younger whom failing a third person and the younger person has died intestate. In this case the conditional institute takes in preference to the younger person's heirs on intestacy. S31(2).

3. Para 3.2.

might arise if a beneficiary disposed of property, to which he thought he had succeeded, within the statutory period. We have accordingly opted for a period of five days. To avoid the need to determine the precise moment when the deceased died we think that the period should run from the beginning of the day on which the deceased died.

5.4 In the case of testate succession it seems clear, as a matter of policy, that the testator should be able to specify in his will some other period of required survivance if he so wishes. Specification of a longer period would, so far as we can see, give rise to no new problems. Specification of a shorter period (such as, say, one hour) could in theory give rise to an odd result in relation to a child's legal share, as the following example shows.

A testator leaves a bequest of £10,000 to his only son provided he survives him by one hour. He leaves the residue (£90,000) of his net estate to a charity. He is not survived by a wife or other children. The son dies three days after the testator, survived by a daughter. The son acquired a vested right to the legacy of £10,000. However, the son died within 5 days of the testator and therefore for the purposes of legal share is deemed to have predeceased the testator. Accordingly his daughter can claim her legal share which, at 30% of the net estate, comes to £30,000.

We considered whether it was worth devising special rules, or even prohibiting a shortening of the standard period of 5 days, in order to deal with this type of situation. In the end we concluded that neither special rules nor a restriction on testamentary freedom was justified. Situations of the type described would be rare and the remedy for them lies in a testator's own hands. In the case of succession to the deceased under a special destination in a title to property we think that the same period of survivance should be required but we do not believe that it is necessary to provide for variation of the standard period. We therefore recommend that:

- 21. A person who fails to survive for at least five days from the beginning of the day on which a deceased person died should be treated as having failed to survive the deceased person,**
- (a) for the purposes of intestate succession to the deceased's estate,
 - (b) for the purposes of the legal shares of spouse or children in the deceased's estate,
 - (c) unless the will specifies some other period, for the purposes of testate succession to the deceased's estate, and
 - (d) for the purposes of succession to the deceased's interest in property which is subject to a special destination.

(Clause 28)

Presumptions of survival

5.5 A rule such as that recommended above would make presumptions of survival (such as that the younger is presumed to survive the elder) much less necessary. In most cases of common calamity it would be possible to conclude, even if the order of death were uncertain, that one person had not survived the other for five days. There would, however, still be a few cases where it was not known whether one person had survived another for five days. For example, the bodies of a husband and wife might be found on a yacht which had been missing for some months and it might not be possible to say whether one had survived the other for five days. There could also be cases where a testator expressly required survival for only an instant for the purposes of succession to his testate estate. In memorandum 71 we expressed the view that a presumption that the younger person survived the elder was not the best solution for this type of situation.¹ It could easily result in the property of the elder person being distributed in ways which he would not have wished and which his surviving relatives would find hard to accept. We suggested that a better approach

1. Para 3.3.

would be to distribute each person's property as if he or she had survived the other for the required period.¹ All consultees who commented on this point agreed with the substance of this proposal, although one commentator suggested that it would be easier to follow if the rule were turned round the other way and provided that each person's estate would be distributed as if the other had predeceased. We accept this suggestion. A rule on these lines would provide a satisfactory solution, which would not be achieved by a simple repeal of section 31 of the Succession (Scotland) Act 1964, in the following type of case.²

Two sisters die in such circumstances that it is not possible to say whether either survived the other for five days. Each has left her estate to the other and "if she predeceases me" to certain legatees.

If section 31 were simply repealed without replacement then, as there is no presumption of survival in the common law of Scotland which could regulate the position, both estates would fall into intestacy because the legatees would be unable to establish that there had been the necessary predecease.³ Under our proposal the estate of each testatrix would be disposed of as if the other had predeceased her. So the estates would pass to the legatees rather than falling into intestacy. We recommend that:

22. Where two persons die in such circumstances that it cannot be established whether either survived the other by five days or, for purposes of testate succession, by such other period as may be specified in the will, the estate of each should be distributed as if the other had failed to survive him or her for the required period.

(Clause 28(4))

Property passing directly from someone else to survivor, or first to die, of two or more persons

5.6 The above recommendation deals with problems of survivorship in relation to succession to the deceased's estate. It may happen, however, that under a will or trust, or under an insurance policy or some other obligation, property is to pass directly from someone else to whichever of two or more persons survives the other or others. In such a case the property would not form part of the estate of either or any of those persons before his death and the rules recommended above would not apply. We suggested in memorandum 71, and most consultees agreed, that in this type of situation it would be inappropriate to have a requirement of survival for a specified period. It would, however, be useful to have a rule for the disposal of property in circumstances where the persons concerned died simultaneously or in such circumstances that it could not be established which survived the other or others. In memorandum 71 we suggested that the fairest solution would be to divide the property equally between or among the estates of the persons concerned.⁴ This was approved by all of those who commented on it. A similar problem could arise if property, such as insurance money, is to go to the estate of the first to die of two or more persons and indeed in any case where the right to property depends on the order of deaths. The same solution appears appropriate in all such cases. We therefore recommend that:

23. Where property is to be transferred to one of two or more persons, depending on the order of their deaths, and does not form part of the estate of either or any of those persons before his death then if those persons have died simultaneously or in such circumstances that it cannot be established which of them survived the other or others the property or its value should, unless the obligation to transfer contains any provision to the contrary, be divided equally between or among the estates of those persons.

(Clause 28(5))

1. Para 3.4.

2. Cf *Ross's J F v Martin* 1955 SC (HL) 56. In this case two sisters, aged 79 and 74, died because of a gas leak in their house. The 5 day rule would have solved the legal problem which arose.

3. *Ross's J F v Martin*, above. A similar problem can arise in relation to representation in intestacy and in relation to the *conditio si institutus*. See *Mitchell's Ex v Gordon's Factor* 1953 SC 176.

4. Para 3.7.

Application of new rules

5.7 In memorandum 71 we suggested that the new rules on survivorship should only affect wills and other testamentary writings executed after the commencement of the new legislation.¹ The Law Society of Scotland disagreed and suggested that, having regard to the nature of the provisions in question, it would be appropriate for them to apply to all deaths occurring after the commencement date. We think that this is right. Some of the rules (eg the 5 day rule) apply in cases of intestacy and it would seem to be undesirable, particularly in cases of partial intestacy, to have one set of rules applying for one purpose and another for other purposes. Any express provision on survivorship in a will or other document would continue to apply and, in the absence of any such provision, we do not think it at all likely that the proposed new rules would lead to results which a testator would not have wished. We therefore recommend that:

24. The new rules on survivorship should apply in relation to deaths occurring after the commencement of the new legislation.

(Clause 34(1))

In some cases it might not be known whether a death occurred before or after the commencement of the legislation. This is a general problem and we recommend later² that in such cases the death should be deemed to have occurred after commencement.

1. Para 3.8.
2. Para 9.25.

Part VI Special Destinations

Introduction

6.1 A destination in a title to property regulates the devolution of that property on the death of the owner or grantee. Examples of destinations are “to A and on A’s death to B”, or “to A and B and the survivor of them”. Prior to 1868 destinations were used extensively in order to circumvent the rule that heritable property could not be disposed of by will. Persons who wished to leave their heritage to individuals other than their heirs-at-law granted conveyances to the chosen individual and very commonly went on to state how the property was to pass on the death of the grantee. Section 20 of the Titles to Land Consolidation (Scotland) Act 1868 made it competent to bequeath heritage by will or general testamentary disposition. A destination in a title to property thereafter began to be known as a “special destination” since it applied to the particular item of property, in contrast to a will which disposed of the testator’s property generally. Special destinations are not confined to heritage; they are also met with in share, bond or other security certificates.

Destinations in titles to property

6.2 In memorandum 71¹ we asked whether it should continue to be competent to insert special destinations in titles to heritable or moveable property. The arguments in favour of abolishing special destinations can be summarised as follows:-

- (a) Special destinations have outlived their purpose and should be consigned to the lumber room of legal history.
- (b) Destinations create conveyancing difficulties which lead to increased costs in transactions. The law as to the construction of destinations and their effect on the rights of the parties involved can be exceedingly complex and obscure.
- (c) The co-existence of wills and special destinations, both of which have testamentary effect, may lead to the frustration of testators’ intentions. In preparing a will a prior special destination may be overlooked or its effects not properly taken into account, so that on the testator’s death the will and special destination conflict. The resolution of these conflicts has produced much complex law, although the recommendations we make later in this part² should simplify matters.
- (d) Evacuation of a special destination, that is disposal of the property otherwise than under the destination, frequently leads to errors. A valid evacuation requires that power to evacuate exists and that the evacuation is carried out in the correct legal form. Whether power exists to evacuate depends upon express agreement or more commonly an agreement implied from the financial arrangements made between those involved in the destination at the time of its creation. Since 1964 a special destination is revoked by a later will only if the will “contains a specific reference to the destination and a declared intention on the part of the testator to evacuate it”.³ Problems also arise when a special destination involving a married couple is not altered on separation or divorce.

1. Para 3.12.

2. Paras 6.18-6.22 below.

3. Succession (Scotland) Act 1964, s 30; *Marshall v Marshall's Ex* 1987 SLT 49.

6.3 There are, however, arguments for keeping at least the well-known destination to two named persons and the survivor of them. The effect of this is to vest each in a share of the property which he or she can sell while alive although there may be restrictions on disposal by will. On the death of the predecessor the whole property passes (unless the destination has been validly evacuated) automatically to the survivor without any process of completing title. Such a destination enables a married couple or others who live together to settle the devolution to what is likely to be their most valuable asset (their house) without having to make wills. Furthermore, the automatic vesting of the property in the survivor reduces the expense of obtaining confirmation to the predecessor's estate and, where the property subject to the destination is the only asset, avoids the need for confirmation.

6.4 On consultation the majority were in favour of allowing people to continue to create special destinations in titles to property. Two individuals thought that the complexity and opportunities for error special destinations created outweighed any advantages they had. The Halliday Committee considered this issue in 1966.¹ They recommended that it should cease to be competent to insert in titles to heritage destinations other than (a) to two or more persons and the survivor(s) of them and (b) to one person in liferent and another in fee.² To assist us in reaching a conclusion we investigated the use of special destinations in recent transactions involving heritable property in Scotland. 1,000 titles recorded in the Register of Sasines or the Land Register for Scotland towards the end of 1985 were examined. Just over one half of these (527) contained a special destination. All these destinations were to two or more persons and the survivor(s) of them. The overwhelming majority (97.5%) of people involved in special destinations were married, engaged, or cohabiting couples. Most of the thirteen other cases (2.5%) concerned close relatives such as brothers, sisters or a parent and child. Nearly all (92%) married couples who took the title to their homes in name of husband and wife included a survivorship destination. Survivorship destinations are clearly widely used at least as far as domestic conveyancing is concerned, indicating that they fulfil a useful role. We have therefore come to the view that such destinations should be retained. Although no examples of liferent and fee destinations were found in our research sample, the absence of reported difficulties leads us to support the Halliday Committee's recommendation that they should be retained.³ Other destinations such as "to A whom failing B", or "to A and on his death to his eldest child" should we think, cease to be competent as the difficulties they give rise to outweigh any practical benefits.

6.5 Although special destinations other than survivorship destinations in titles to moveable property are uncommon we would apply our recommendations to all property since it would be undesirable to create fresh distinctions between heritable and moveable property. It is not, however, our intention to prohibit trust titles to persons and their successors in a particular office or position.⁴

6.6 The Halliday Committee recommended that the Keeper of the Register of Sasines (and now also the Land Register for Scotland) should be empowered to refuse to register a deed containing a special destination (other than a survivorship or liferent destination) and to cancel the registration where the defect came to light afterwards.⁵ We are not in favour of this approach. First, non-registration prejudices the initial grantees who are unable to obtain real rights to the property. Secondly, it could only with great difficulty be extended to destinations in titles to moveable property since there is no central registering authority for such titles. A better solution is to have a rule that the destination is legally ineffective beyond the original grantee(s) and, in the case of a survivorship destination, the survivor of them, so preserving the effectiveness of all the other parts of the document creating the destination. Thus a destination to "A whom failing B" would simply be a destination to A, a destination

1. Report on *Conveyancing Legislation and Practice* (Chairman, Professor J M Halliday) 1966 Cmnd 3118.

2. Para 144.

3. There is no express saving for liferents in the draft Bill but the wording of clause 29(1) is such that a destination "to A in liferent and B in fee" would not be caught. It is not, in terms or substance, a destination in favour of A whom failing B. It creates separate interests for A and B from the outset.

4. See clause 29(2).

5. Para 144.

to “A and B and the survivor of them and on the death of the survivor to his or her eldest child” would simply be a destination to “A and B and the survivor of them”. Our recommendation would, in general, affect only destinations contained in documents executed after the commencement of any implementing legislation. However, where a will contains a substitution (for example, a bequest of heritable property “to A whom failing B”)¹ the executor must set out the terms of the substitution as a special destination in the document of transfer in order to implement the will. It should continue to be competent to create such a destination after commencement provided the will was executed before commencement. We recommend that:

25(a) A special destination in a future title to property (other than a survivorship destination) should be ineffective in so far as it provides for the succession of persons other than the original grantee or, in the case of a destination containing a survivorship destination, the original grantees and the survivor of them.

(b) This rule should not apply:

- (i) to destinations to one person in liferent and another in fee,**
- (ii) to destinations to a person as a trustee or holder of an office or position and his or her successors as such, or**
- (iii) to destinations implementing a provision in a will executed before commencement.**

(Clauses 29(1), (2) and 34(4))

Deemed destinations

6.7 The effect in Scotland of taking a title to property in names of more than one person is to make the property common property rather than joint, unless there is an independent relationship between the owners such as being trustees under a trust, partners or members of a club or an incorporated association.² Where the property is common the share of a co-owner forms part of his or her estate rather than passing to the survivor(s). In memorandum 71 we considered whether a title to more than one person should be deemed to include a survivorship destination. We pointed out that the advantages and disadvantages of deemed survivorship destinations were much the same as for express survivorship destinations. However, the chance of overlooking a latent deemed destination when making a will or distributing an estate or on divorce would be far greater than with an express destination.³ We proposed that deemed survivorship destinations should not be introduced.⁴ All those who commented agreed. One solicitor pointed out that a deemed survivorship destination would produce results that would not be in accord with the intentions of business partners who joined together to buy their business property. We think that if survivorship destinations are desired, express provisions to that effect should be required and accordingly we do not recommend the introduction of deemed destinations in Scots law.

Destinations in wills and trusts

6.8 Wills, other documents of a testamentary nature, and trust deeds may contain destinations. A simple example is a legacy to A whom failing B. If A predeceases the testator but B survives, B will take the bequest whatever the nature of the property bequeathed.⁵ Where both A and B survive the testator the effect of the destination depends on the nature of the property bequeathed. For a bequest of moveable property, such as money or furniture, A takes the bequest and B has no further right

1. See paras 6.8-6.9 below.

2. *Magistrates of Banff v Ruthin Castle Ltd* 1944 SC 36 per Lord Justice-Clerk Cooper at p 68.

3. Paras 3.38-3.39.

4. Para 3.40.

5. B may be defeated if A is a close relative of the testator and leaves issue surviving the testator, see para 4.50 above.

to the property.¹ On the other hand where the subject of the bequest is heritage, such as a house or a shop, A takes the bequest subject to the destination to B. On A dying without having disposed of the property, it passes to B under the destination.² A bequest of moveables and heritage, such as a house and its contents, follows the rule for moveables. These rules of course apply in the absence of any contrary intention expressed by the testator in the document in question. The testator's executor should implement the destination in the will relating to the bequest of heritage by repeating it in the document of title transferring the property to A.

6.9 We recommended earlier that a destination of the type "to A whom failing B" in future titles to property should not be effective in relation to B, except in implement of existing wills.³ Where a will executed after commencement contains such a destination in a bequest of heritable property the executor would be unable to give effect to it in the document transferring title to the first named beneficiary (A). It therefore seems sensible to render ineffective such destinations in future wills and similar documents in so far as they purport to carry property, which has vested in A, to B on A's death.⁴ Another argument for rendering such destinations ineffective to carry property to B once it has vested in A is that the existence of the special rule for heritage is not widely known. It is natural to assume, if such property is left "to A whom failing B", that B's right will fly off once the property has vested in A. Bequests with such a destination have become a trap for the unwary, both in preparing wills for, and distributing the estates of, testators and their special destinies. Accordingly we recommend that:

26. Where a will, other testamentary document, or trust deed is executed after commencement containing a destination to a beneficiary whom failing another person or persons, that part of the destination relating to the other person or persons should become ineffective as soon as the property in question has vested in the beneficiary.

(Clause 29(5))

Definition of a special destination

6.10 The Succession (Scotland) Act 1964 contains no definition of a special destination although the term appears several times. The scheme of the Act is to exclude from a deceased's estate heritable property subject to an unevacuated special destination.⁵ The special donee succeeds to the property by virtue of the special destination not the deceased's will. However, the executor's intervention may be necessary to transfer title to the property to the donee. Section 18(2) provides that property passing under an unevacuated destination vests in the deceased's executor confirming to it, but the property vests for the sole purpose of transferring title (if necessary).⁶ Finally, a prior special destination is revoked by a later will only if the will specifically refers to the destination and contains a declared intention to evacuate it.⁷

6.11 In *Cormack v McIlldowie's Exs*⁸ a destination in a pre-1964 agricultural lease to a father and son "as joint tenants and to the survivor of them as sole tenant, and to the heirs of the survivor, but excluding heirs-portioners (the eldest heir-female always succeeding without division), sub-tenants and assignees..." was held not to be a special destination. The decision was reached on the basis that a special destination is one in which "the particular property in the deed is disposed to a particular person

1. This is known as a conditional institution. A is the institute and B is the conditional institute.

2. This is known as a substitution. A is the institute and B is the substitute.

3. Para 6.6 above.

4. In more technical terms what we are recommending is that such destinations should take effect as conditional institutions and not as substitutions.

5. Proviso (a) to s 36(2).

6. A destination "to A whom failing B" requires A's executor to transfer title to B. In the common case of a survivorship destination "to A and B and the survivor" on A's death B automatically acquires title to the whole property without any transfer by A's executor.

7. S 30.

8. 1975 SC 161.

(or persons) *specifically nominated by the granter*, without regard to the normal operation of the law of succession on intestacy".¹ (Emphasis added.)

6.12 In memorandum 71 we pointed out that this definition had been criticised since it seems to exclude a destination to a class of unnamed persons, such as the children of X.² We proposed that a destination to an unnamed class of persons should be a special destination, except where the class is "heirs".³ These latter are excluded since it is a vital component of a special destination that it directs the property to persons other than heirs on intestacy.⁴ All those who commented agreed with our proposal. We recommend that:

27. A special destination in a deed should be a destination by which the property in question is to devolve upon a named or identified person (or persons) or upon a class of persons (other than "heirs").

(Clause 36(1) and Schedule 1, paragraph 13)

6.13 The definition of a special destination which we have just recommended would cause problems with the transfer of a deceased tenant's interest in a lease. We understand that most formal pre-1964 agricultural leases and (surprisingly) some of those executed after 1964 contain a destination excluding heirs-portioners and providing that the eldest heir-female should succeed without division. Prior to 1964 this destination was desirable since it ensured that a single person succeeded to the tenancy. After 1964 such a destination is unnecessary to achieve this purpose because of the power of transfer to a single beneficiary available to the executor under the 1964 Act. A destination preferring an identified person (the eldest heir-female) is inconsistent with the normal rules of intestacy and hence in terms of the definition in paragraph 6.12 above, would be a special destination. The tenant's interest in a lease containing a special destination is not part of the deceased tenant's estate⁵ and so cannot be transferred by the executor under section 16 of the 1964 Act. Section 16 enables the executor to select a transferee from amongst those entitled to the estate, notwithstanding any express prohibition on assignation contained in the lease. This power is useful in that the executor may be able to select someone who is interested in taking over the tenancy and would be sufficiently experienced or qualified to be acceptable to the landlord.

6.14 In memorandum 71 we put forward two methods of dealing with the exclusion of heirs-portioners and the preference for the eldest heir-female.⁶ The first was to provide that such a destination should not be a special destination for the purposes of the 1964 Act. The second was to ignore the exclusion of heirs-portioners and the preference for the heir-female. The destination would then become to the heirs of the tenant which, as we have already stated⁷, is not regarded as a special destination. While all those who commented were in favour of our general approach, with a majority favouring our first method of achieving it, we have reconsidered the matter. We start from the position that it should remain competent to insert special destinations in leases, for in that way the tenancy can devolve to prescribed persons whom the landlord has consented to in advance.⁸ A farmer with three daughters ought to be able, by obtaining a lease with a preference for the eldest daughter, to pass on the tenancy to her. The approach we now favour would be that a special destination should exclude the lease from the ambit of section 16 only if, in the circumstances that actually occur on the tenant's death, the destination regulates the succession. To illustrate our new approach, suppose a tenant farmer has a lease excluding heirs-portioners and providing that if there are heirs-portioners the eldest heir female is to succeed. If the farmer dies leaving only daughters, the eldest would take under the destination. On the other hand, if the farmer was survived by sons or sons and

1. Lord Justice-Clerk Wheatley at p 177.

2. Professor J M Halliday, "What Makes a Destination Special?", *Journal of the Law Society of Scotland*, 1977, p 16.

3. Para 3.30.

4. *Reid's Trs v Macpherson* 1975 SLT 101.

5. Proviso (a) to s 36(2).

6. Para 3.30.

7. Para 6.12 above.

8. See para 6.23 to 6.29 below.

daughters, the destination would be ineffective so that the executor could use the section 16 power to transfer the tenancy to any one of the beneficiaries. We would generalise this to property other than interests under leases. Only where a special destination of any kind actually takes effect would the property passing thereunder be excluded from the deceased's estate for administrative purposes unless the executor's intervention is required in order to transfer the title to the special destinee. Section 18(2) of the 1964 Act provides that property passing under a special destination may vest in the executor on confirmation for that purpose only. We therefore recommend that:

28. Property subject to a special destination should be excluded from the deceased's estate for the purposes of administration under the Succession (Scotland) Act 1964 (unless a transfer by the executor is necessary) only if, in the circumstances that occur, the property passes by virtue of the special destination.

(Schedule 1, paragraphs 12 and 14)

Rights of creditors

6.15 One issue that has recently arisen in connection with special destinations is the liability of the person succeeding to the property by virtue of the destination for the debts of the deceased previous owner. In *Barclays Bank Ltd v McGreish*¹ Mrs McGreish acquired a house and took title to it in the name of herself and her husband and the survivor of them. He subsequently got into financial difficulties and the bank obtained a decree for payment of money against him. However, they did not enforce it before his death. Mr McGreish died leaving no estate other than the half share of the house which passed, or reverted, to his widow under the destination. It was held that this half share passed without liability for the debt to the bank. In view of the controversy² generated by this decision we proposed in memorandum 71³ that, whether or not the decision was correct, legislation should be enacted expressly providing that property passing on death under a special destination should remain liable for the deceased's debts. Our proposal was grounded on the principle that a person's whole estate (except for items such as a liferent that cease on death) should be liable for his or her debts and the rights of lifetime creditors should not be affected by the debtor's death. All those who commented were in favour of our proposal. While we would adhere to the general nature of our proposal, we are now in favour of a slightly different method of achieving it.

6.16 A person succeeding to property by virtue of a special destination is termed an heir of provision of the deceased previous owner. Before the 1964 Act it was clear that an heir of provision was personally liable for the deceased owner's debts up to the value of the property received.⁴ *Barclays Bank Ltd v McGreish* proceeded on the basis that the 1964 Act removed this liability. We would revert to the notion of limited personal liability of the heir of provision rather than introduce, as we originally proposed, the concept of the property remaining liable for the deceased's debts. Personal liability means that once the creditor has constituted the debt of the deceased previous owner against the heir of provision, all the normal forms of diligence can be done against the whole assets of the heir, not merely against the property to which the heir succeeds. Personal liability may be avoided by the heir disclaiming the property passing under the special destination so leaving the creditor to pursue the debt against the disclaimed property or the deceased's other assets. Although the creditor can go against the heir for the full value of the property received, the heir may have a right of relief against other beneficiaries by virtue of the common law rules of incidence of debts or the provisions of the deceased's will.⁵ We recommend that:

1. 1983 SLT 344.

2. D J Cusine, "Of Debts and Destinations", *Journal of the Law Society of Scotland* 1984, p 154; M Morton, "Special Destinations as Testamentary Instructions", 1984 SLT (News) 133; J M Halliday, "Special Destinations", 1984 SLT (News) 180; and G L Gretton, "Death and Debt", 1984 SLT (News) 299.

3. Para 3.24.

4. *Baird v Earl of Rosebery* (1766) Mor 14019; Bell, *Principles*, para 1922.

5. McLaren, *Wills and Succession*, p 1305.

29 A person who succeeds to property by virtue of a special destination should be personally liable for the debts of the previous owner unless he or she renounces the succession. This liability should be limited to the value of the property at the date of the previous owner's death.

(Clause 29(6))

6.17 We envisage that rules of court will require the creditor in bringing proceedings to constitute the debt against the heir to state the amount of the debt. This amount would become the liability of the heir unless he or she asked the court to limit liability to the value of the property as at the date of death. Disputes as to value would be settled by the court after considering evidence of value, such as a valuation by a surveyor or other qualified person.

Evacuation of special destinations

6.18 Generally owners of property may dispose of it by lifetime deed or will as they please. Owners of property subject to a special destination have, in certain cases, restrictions placed on their freedom to evacuate the destination, that is to dispose of the property contrary to the destination. The power to evacuate or restrictions on evacuation may be expressly stated in the deed creating the destination. In the absence of express provisions, the law will imply restrictions in three classes of destinations; a) destinations in marriage contracts in favour of the issue of the marriage¹, b) clauses of return (where the donor gives property to the donee with a destination back to the donor)², and c) survivorship destinations. Only the last class—survivorship destinations—are commonly met with in current practice.

6.19 The owner of property subject to a special destination may while alive sell the property unless (and this would be most unusual) he or she had agreed not to do so. In the case of marriage contract destinations and clauses of return, the law on evacuation is complex and uncertain.³ As far as survivorship destinations are concerned there are restrictions on evacuation by will. In the simple case of a destination to two people and the survivor of them, if each contributed towards the acquisition of the property, a contract is implied with the result that neither can dispose of his or her share by will contrary to the destination.⁴ Where the property subject to the destination has been acquired by one person alone, he or she can dispose of his or her share by will in any manner.⁵ The other owner cannot do so since he or she is taken to have accepted the gift of the share of the property subject to the condition that it will revert to the donor if the donor survives.⁶ It is possible that a gratuitous lifetime disposal inconsistent with the destination is incompetent if evacuation by will would be prohibited, but there is no direct authority and the law is not clear.

6.20 Recent survivorship destination cases indicate that the terms of the deed creating the destination relating how the parties contributed financially to the acquisition of the property may be decisive. In *Gordon-Rogers v Thomson's Exs*⁷ the disposition in favour of a husband and wife and the survivor narrated that the price was paid by them equally. The wife predeceased her husband leaving her share of the property to another person by will. It was held that it was incompetent to lead oral evidence to show that in fact the wife bought the property with her own money which, if established, would have left her free to evacuate the destination of her share. *Smith v Mackintosh*⁸ concerned a mother who disposed her home to herself and her daughter and to the survivor of them. Later she gave her share to her son. After her mother's death the daughter sought to reduce the disposition to the son which

1. Craigie, *Scottish Law of Conveyancing Heritable Rights*, (3rd edn) p 551

2. Craigie, p 552.

3. Craigie, pp 550-553.

4. *Perrett's Trs v Perrett* 1909 SC 522; *Shand's Trs v Shand's Trs* 1966 SLT 306.

5. *Brown's Trs v Brown* 1943 SC 488; *Hay's Trs v Hay's Trs* 1951 SC 329.

6. *Renouf's Trs v Haining* 1919 SC 497.

7. 1988 SLT 618.

8. 1989 SLT 148.

prevented her from inheriting her mother's half share of the house under the destination. It was held that the disposition to mother and daughter disclosed no contractual bar to evacuation and that it was incompetent to lead evidence that the disposition was granted in recognition of the daughter's services and her contributions to repairs and improvements to the property. It is not clear whether written evidence of the parties' financial arrangements can be led to contradict the narrative in a deed creating a destination.

6.21 In memorandum 71 we asked for views on the evacuation of survivorship destinations and put forward three options.¹ The first option left the law as it is, the second prohibited any lifetime or testamentary evacuation of the destination in all circumstances without the consent of the other parties or the court, and the third removed the current restrictions on lifetime or testamentary evacuation of a destination. Any change would only have affected destinations created after the proposed legislation came into force. The second option attracted support from only one organisation. We have little hesitation in rejecting it. As we pointed out in memorandum 71,² a complete prohibition on any disposal would be unworkable and unjust, while the numerous exceptions necessary would make the law complex. For example, provisions would be needed to cope with the situation where one party to the destination wished to dispose of his or her share but the other party either could not or would not consent. Also, creditors' rights would have to be taken care of since it would be wrong to create a species of property which parties to a destination could enjoy, but which was exempt from the diligence of their creditors or sequestration. In conclusion, we do not think such a restrictive and complex regime would be acceptable.

6.22 Although there was some support on consultation for leaving the law as it is, there was a clear majority in favour of our third option—giving owners of property subject to a survivorship destination freedom of disposal. This would bring about a considerable simplification of the law. The rule presently applying to lifetime sales would apply to all disposals. Of course, if a person had contracted not to dispose of his or her share and then disposed of it that would make him or her liable for damages for breach of contract, just as in the case of a sole owner who broke a contract not to dispose of property. The disposal itself, however, would not be affected. The new rules should apply only to post-commencement destinations; it would, we think, be wrong to interfere with the effect of existing destinations. We recommend that:

30(a) The owner of property subject to a special destination should have power to dispose of it whether for value or gratuitously, either during life or on death, whether or not the destination is contractual in nature, and regardless of who paid for the property.

(b) The above recommendation should apply only to destinations contained in documents executed after the date of commencement of implementing legislation.

(Clauses 29(3) and 34(4))

Special destinations in leases and assignments of leases

6.23 In this final section we consider the extent to which our previous recommendations relating to special destinations in titles to property should be applied to destinations in leases and assignments of leases. We have already dealt with a particular aspect of special destinations in leases—the exclusion of heirs-portioners. We now consider the topic more generally. There are three separate but interlinked issues; the continued competence of special destinations in leases and assignments of leases, their evacuability and their effect on the rights of creditors.

Continued competence

6.24 Where assignment of the tenant's interest in a lease is expressly or impliedly excluded or permitted only with the consent of the landlord, the landlord has a

1. Para 3.18.

2. Para 3.15.

continuing interest in who the tenant is. A special destination in a lease is in effect a contractual arrangement between the parties involved regulating the succession to the tenant's interest. Special destinations serve a useful function for they enable tenants to obtain their landlord's consent in advance to particular successors. From the point of view of the landlord, a special destination ensures that the tenancy passes to an approved person rather than a legatee or a transferee to whom objections might have to be taken.¹ We do not think there should be any restriction placed on the type of contractual arrangement that landlords, tenants and their successors may enter into.

6.25 In the case of a freely assignable lease the landlord has no veto on disposal or bequest by the tenant of his or her interest so that a special destination has none of the advantages referred to above. The benefits and drawbacks of special destinations in freely assignable leases are the same as for those in freely disposable property.² In connection with titles to property we came to the view that the balance of convenience is in favour of limiting special destinations to survivorship destinations or liferent and fee destinations and recommended accordingly.³ We would extend this recommendation to destinations in freely assignable leases so that only survivorship destinations could be created in future leases of this type.⁴

6.26 The rules for assignments of leases ought to follow those for leases themselves. In a non-freely assignable lease the landlord's consent imports a contractual element into the assignment and the destination it contains. Parties should be free to make by way of destination in an assignment whatever arrangements they wish regarding the devolution of the tenant's interest. However, assignments of freely assignable leases are really like dispositions of freely disposable property and should follow the same rule. We therefore recommend that:

31 Recommendation 25 should apply to future leases where assignment is permitted without the landlord's consent and to assignments of such leases, but not to other leases or assignments of leases.

(Clauses 29(1), (4) and 34(4))

Evacuation

6.27 The evacuability of a special destination contained in a lease depends on the tenant's power to assign or sub-let. In *Lord Boyd v HM Advocate*⁵ the estate of Linlithgow was let for 38 years to the Earl and Countess of Kilmarnock and the survivor of them and the heirs and executors of the survivor. The Earl was executed for his part in the 1745 rebellion and his estates were forfeited to the Crown. The whole subjects of the lease however passed to the Countess as survivor and on her death to her heir, Lord Boyd. Neither the Earl nor the Countess had, under the terms of the lease, power to assign so as to defeat the right of the survivor to become sole tenant. Any rights that the Crown could have obtained by forfeiture would have terminated on the death of the Earl.⁶ It is worth noting that had the Earl and Countess held the estate as owners under the same destination, the Earl's treason would have resulted in his share passing to the Crown.⁷ *Macalister v Macalister*⁸ is another example of the different rules relating to evacuation of a destination in a lease. A landowner granted a lease of his estate for 38 years to his daughter and her husband and the survivor of them whom failing to one of their sons and his heirs and assignees. It was held that the named son had a contractual⁹ right to become tenant on his parents' deaths which could not be defeated by his father's sub-lease to another son. Such a destination in a feudal title would not have protected the son's succession.¹⁰ We

1. See also Sutherland, "Special Destinations and Agricultural Leases" 1989 SLT (News) 256.

2. See paras 6.2-6.3 above.

3. Para 6.6 above.

4. A liferent and fee destination is inapplicable to a tenant's interest in a lease because a fee is an absolute right of ownership.

5. (1749) Mor 4205.

6. Rankine, *Leases*, p 85.

7. *Earl of Perth v Lady Willoughby de Eresby's Trs* 1871 9M (HL) 83.

8. (1859) 21D 560.

9. The son signed the lease. It may be doubted whether the same result would have obtained had he not been a contracting party.

10. Lord Neaves (the Lord Ordinary) at p 562 whose judgment was affirmed on reclaiming.

think that contractual arrangements between landlords and tenants regarding the devolution of the tenant's interest in a non-freely assignable lease should continue to be binding on the parties involved (if that is their intention) as under the present law. Destinations in assignations of non-freely assignable leases also contain a contractual element between the landlord and the tenants by virtue of the consent of the landlord to the terms of the destination. We would therefore except special destinations in non-freely assignable leases and assignations of such leases from our previous recommendation¹ permitting evacuation of destinations in titles to property. Freely assignable leases, and assignations of such leases, should, however, be in the same position as dispositions. We recommend that:

32 Recommendation 30 should apply to future leases where assignation is permitted without the landlord's consent, and to assignations of such leases, but not to other leases or assignations of leases.

(Clauses 29(3), (4) and 34(4))

Rights of creditors

6.28 The final issue we consider is the liability of a person succeeding to a deceased tenant's interest under a lease by virtue of a special destination for the debts of the deceased tenant. In *Robertson's Trs v Roberts*² a husband and wife were the assignees of a 999 year lease of a dwellinghouse. The assignation contained a survivorship destination—to the husband and wife and the survivor of them. It was held that after the husband's death his trustee in sequestration had no claim to the share of the house passing to the wife under the destination in the assignation. Had the assignation been a disposition of feudal property the trustee would have been successful since any destination does not affect a trustee in sequestration or an adjudger. The implication of this decision is that the successor under a special destination contained in an assignation of a lease is not liable for the debts of the person to whom he or she succeeds. We recommend above that in feudal property a successor should be liable.³ We proposed in memorandum 71 that the feudal property rule should apply to destinations in assignations of long leases since leasehold with leases such as 999 years is virtually equivalent to feudal tenure.⁴ Although all those who commented agreed we now think the correct distinction is not between long⁵ or short leases but between freely assignable and non-freely assignable interests. The categories to a large extent overlap since very long leases are freely assignable. In a non-freely assignable leasehold interest, action by creditors prejudices the landlord, but this factor is absent in freely assignable interests.

6.29 We do not propose to deal with rights of creditors to attach non-freely assignable interests in this report. In our recent Discussion Paper on "Adjudication for Debt and Related Matters: Volume II"⁶ we invite views on the extent to which creditors should be able to attach a tenant's interest by way of adjudication where assignation requires the consent of the landlord.⁷ Any question of the liability of a successor for the previous tenant's debts must clearly await a decision on whether the previous tenant's interest itself is attachable for debt. We therefore confine our recommendation to assignations of freely assignable leases and recommend that:

33. A destination in an assignation of a lease where assignation is permitted without the consent of the landlord should, as far as the rights of creditors of the assignees are concerned, have the same effect as the same destination in a disposition of feudal property.

(Clause 29(7))

1. Para 6.22 above.

2. 1982 SLT 22.

3. See para 6.16 above.

4. Para 3.25.

5. A long lease is a probative lease exceeding 20 years or containing an obligation to renew so that the total duration could extend for more than 20 years; Land Registration (Scotland) Act 1979, s 28(1).

6. Discussion Paper No 78, published November 1988.

7. Para 5.15.

Part VII Disqualification of certain heirs

Introduction

7.1 Scottish succession law is generally speaking not concerned with the worthiness of those who inherit. Provided a person fulfills the requirements of the rules of testate or intestate succession, such as surviving the deceased or being one of the issue of the deceased, he or she is entitled to succeed. In this Part we examine the two existing exceptions to this general rule, unlawful killers and judicially separated husbands, and discuss whether any further exceptions should be made.

The unlawful killer

Forfeiture 7.2 Disqualification of an heir otherwise entitled to succeed may occur where the heir unlawfully kills the deceased. The relevant legal rules are contained in an old Scots Act and a common law principle. The Parricide Act 1594 disinherits any one convicted of killing a parent or grandparent, and the succession goes instead to the nearest relative who would have succeeded had the killer and all his or her descendants predeceased the deceased. The scope of this Act is fairly restricted. It applies only to the stated relationships and it is thought that the statutory disqualification extends only to succession to heritable property.¹ Despite its antiquity there are no reported cases of it ever leading to disinheritance.²

7.3 The normal formulation of the common law principle is that a person who unlawfully kills another is precluded from taking any benefit from the deceased's estate. But this is merely a particular case of a wider rule (which would apply, for example, to social security benefits or benefits under life insurance policies) that a person is not allowed to invoke the aid of the law to claim a benefit from his or her crime. The principle is based on public policy, equity and morality and has been applied in Scotland in two recent cases. In *Smith, Petr*³ the uncle of the deceased (who died intestate) applied to be appointed executor. He averred that the deceased's wife was excluded from the succession and hence from being appointed executor as she had been convicted in Northern Ireland of the manslaughter of her husband. The sheriff held that a conviction for manslaughter or culpable homicide was an absolute bar to succession.⁴ In *Burns v Secretary of State for Social Services*⁵ a claim for a widow's allowance by a wife who had been convicted of the culpable homicide of her husband was disallowed. But it seems that a conviction for culpable homicide does not form an absolute bar. As Lord President Emslie said⁶ "...not every kind of culpable homicide will necessarily result in the application of the general rule." Neither of these cases was affected by the Forfeiture Act 1982 as proceedings had commenced before the Act came into force. This Act allows the court to grant relief from forfeiture incurred under the common law principle and is discussed later. The following discussion on forfeiture assumes that discretionary relief will continue to be available to those who have forfeited their rights of succession.

1. Bankton, *Institute*, III 4.30. The Act speaks of "landis heretages takis possessions".

2. In the only reported case on the 1594 Act the alleged killer escaped forfeiture because he had fled abroad to escape conviction. *Oliphant v Oliphant* (1674) Mor 3429. Another aspect of the same case is reported as *Yeaman v Oliphant* (1663) Mor 4773.

3. 1979 SLT (Sh Ct) 35.

4. The application was rejected for another reason.

5. 1985 SLT 351.

6. At p 353.

7.4 In memorandum 71 we put forward the view that the present law on forfeiture was in need of reform.¹ The Parricide Act 1594 is archaic, it applies only to the killing of parents and grandparents, the killer must have been convicted, and it probably does not affect the killer's rights of succession to the deceased's moveable estate. The common law rule is imprecise as to whether all unlawful killing results in forfeiture, what other crimes (if any) result in disinheritance, and the extent to which the crime must have resulted in the death.² We proposed that there should be a new statutory provision disqualifying those who have committed the crime of murder or culpable homicide against the deceased from succeeding to the deceased in any way.³ This was accepted by virtually all those who commented.

7.5 One of the problems with a statutory reformulation of forfeiture lies in deciding what crimes should result in the disinheritance of the heir. The Parricide Act 1594 deals only with slaying, while the common law rule certainly encompasses both murder and culpable homicide and analogous crimes in other jurisdictions.⁴ All the countries whose laws we have studied disinherit persons who have unlawfully or culpably killed the deceased, but many include other crimes as well. In the Republic of Ireland attempted murder is included⁵, and French law declares a person who has unjustly accused the deceased of a capital crime or has failed to notify the authorities of the murder of the deceased to be unworthy to succeed.⁶ In several Eastern European countries those who kill near relatives of the deceased are disinherited⁷, while the law in Israel disqualifies a person who has been convicted of concealing, destroying or forging the deceased's last will.⁸ In memorandum 71 we asked what other crimes (if any) besides murder and culpable homicide should result in the heir's forfeiture.⁹ Most of the consulted organisations were against any extension, but one half of the individual respondents (18 out of 36) suggested additional crimes. The range of crimes suggested (rape, theft, abuse of children of the deceased, serious assault, and violence rendering the deceased incapable of making or altering a will) indicate the difficulty of drawing up a list of crimes that would be generally acceptable. We have come to the conclusion that any new statutory provision on forfeiture should be limited to the murder or culpable homicide of the deceased, or an analogous crime committed abroad. For these crimes there is a direct link between the commission of the crime and the opening of the succession to the criminal which may be lacking in other crimes. The public policy principle that no-one may invoke the aid of the law to claim a benefit from his or her own crime, which would be retained as a common law rule, would be available to disinherit for example a fiar who killed the liferenter in order to accelerate possession of the property, or someone who killed off those with a better claim to succeed so as to insure his or her inheritance in due course.¹⁰ It might also be available to deal with an heir who had rendered the deceased incapax and therefore incapable of changing his or her will so as to cut out the heir.

7.6 Another approach to persons who commit serious crimes against the deceased would be to exclude them from claiming legal share.¹¹ A victim would then be able to disinherit by will a spouse or descendant who assaulted or defrauded him or her without the disinherited relative nevertheless being entitled to claim a substantial proportion of the estate by way of legal share. In memorandum 71 we asked for views on this approach.¹² Most of those who commented were against it. The problem lies in first deciding what crimes should debar those otherwise entitled to claim legal share from claiming and then finding a simple formula to encompass them.

1. Para 2.7.

2. For example, is a son disinherited if he batters his mother nearly to death, but she dies because the ambulance crashes on the way to hospital?

3. Proposition 1(a), of para 2.11.

4. In *Smith, Petr* 1979 SLT (Sh Ct) 35 the wife had been convicted in Northern Ireland of her husband's manslaughter.

5. Succession Act 1965, s 120.

6. Code Civil, arts 727-728.

7. *The Law of Inheritance, Law in Eastern Europe Series, Vol 5.*

8. Succession Act 1965, s 5(a).

9. Para 2.11. A similar question (Question 18) was asked in the pamphlet.

10. As in the film "Kind Hearts and Coronets".

11. The Republic of Ireland's Succession Act 1965, s 120.

12. Para 2.11.

7.7 One difficult issue is whether a conviction for murder or culpable homicide should be a prerequisite for forfeiture or whether it should be possible to declare succession rights to have been forfeited by civil proceedings. Disinheritance under the Parricide Act 1594 requires the slayer to have been convicted. In England and Wales the common law forfeiture rule has been applied to an unconvicted killer¹, and it is very likely that the Scottish courts would adopt a similar approach. In memorandum 71 we posed the question of whether a conviction should be required.² Opinion was divided on this issue. Those who favoured the need for conviction did so on grounds of certainty and ease of administration of the estate. In the absence of a conviction the deceased's executors would be entitled to distribute the estate to those succeeding under the will or the rules of intestacy. On the other hand requiring a conviction could lead to manifest injustice. A person who on the face of all the evidence had killed the deceased would be entitled to inherit or pass on the inheritance if he or she could not be brought to trial. For example, the killer may have committed suicide afterwards³, died before the case came to trial, fled abroad to escape the consequences⁴, or have been liberated under the statutory provisions for the prevention of delay in trials.⁵ Although we were initially attracted to the need for a conviction, we are now of the opinion that the needs of justice outweigh the desirability of certainty and the convenience of executors, and accordingly conclude that forfeiture should not necessarily require a prior conviction.

7.8 The policy we have adopted is that a person who has unlawfully killed the deceased, whether or not convicted by a criminal court, should forfeit all rights that he or she would otherwise have been entitled to on the deceased's death. These rights include rights of succession to the deceased's estate, rights to property held in trust which devolve upon the killer on the deceased's death, rights under insurance policies or pension plans and social security benefits. It remains to find the best legislative way of achieving this policy. Where a conviction has been obtained, forfeiture should be automatic by virtue of a new statutory provision which would replace the Parricide Act 1594. It seems to us unnecessary to require a civil court to declare that forfeiture has been incurred if a person has been convicted of murder or culpable homicide by a competent criminal court. A civil court could be involved at a later date if the convicted person applied for relief from forfeiture under the provisions of the Forfeiture Act 1982, but that is a separate matter.

7.9 Where no conviction had been obtained a civil court would require to be involved in establishing forfeiture arising out of an unlawful killing only if the parties concerned did not accept that forfeiture had occurred. Civil proceedings based on averments of criminal conduct would not be a novelty.⁶ In the absence of express legislative provision, the civil standard of proof and rules of evidence would apply and the Lord Advocate would not have to be involved. In practice civil proceedings would be unlikely to be brought until it was clear that there was not going to be a criminal prosecution.

7.10 Although we did consider at one stage whether there should be legislation to regulate the possible overlap between civil and criminal proceedings arising out of forfeiture—for example, by providing for the Lord Advocate's concurrence to be necessary before civil proceedings could be brought—we have come to the conclusion that such legislation would be unnecessary. It has not been found necessary so far and the number of cases involving unconvicted killers would be very small. In the vast majority of cases of suspected unlawful killing, a criminal trial would be held and the estate would be distributed in accordance with the verdict.

1. *Re Dellow's Will Trusts* [1964] 1 All ER 771. The wife killed her husband and committed suicide.

2. Para 2.11.

3. As in *Re Dellow's Will Trusts* [1964] 1 All ER 771.

4. As in *Oliphant v Oliphant* (1674) Mor 3429.

5. Criminal Procedure (Scotland) Act 1975, s 101. Subsection 1 provides that a trial must commence within 12 months of first appearance on petition, while subsection 2 entitles an accused who is directed to be kept in custody pending trial to be liberated after 110 days. These periods may be extended on cause shown.

6. Hume, *Commentaries on Crimes*, Vol II, pp 70-71. For example damages for assault or fraud may be claimed from an unconvicted person.

7.11 We therefore propose to leave forfeiture of unconvicted "killers" to the common law principle that no-one should benefit from an unlawful killing. The rule could be given effect to in civil proceedings on the part of the deceased's executors or others seeking to disinherit the killer, or more likely by proceedings brought by the killer for the purpose of asserting his or her succession rights against executors or others unwilling to pay.

7.12 Up to now we have been discussing convictions solely in the Scottish context. In memorandum 71 we stated our view that a conviction for murder or manslaughter in the other law districts of the United Kingdom should have the same effect as a Scottish conviction for murder or culpable homicide, since the constituent parts of the United Kingdom have very similar standards regarding criminal trials.¹ There was no dissent on consultation. We would extend this to British courts-martial and criminal courts in the Channel Isles and the Isle of Man for similar reasons. We then asked whether a conviction in any other country should necessarily result in forfeiture. None of those who commented drew any distinction between United Kingdom convictions and non-United Kingdom convictions. We think such a distinction is unnecessary. It might be regarded as insulting by those countries with comparable standards of criminal procedure. A person who had been convicted by a court whose standards were not comparable with those of United Kingdom courts would not be left without a remedy. Although forfeiture of Scottish succession rights would be automatic, a Scottish civil court in considering whether to grant relief from forfeiture could take into account any difference in standards.

7.13 If, as we suggest, a foreign conviction should automatically give rise to forfeiture, then the relevant crimes should be those which, if committed in Scotland, Scots law would treat as murder or culpable homicide. Where there was doubt as to the nature of the crime set out in a foreign conviction, an opinion from an expert in the law of the country in question could be obtained, and if this failed to settle the issue an action would require to be brought in a Scottish civil court.

7.14 We recommend that:

- 34(a) New statutory provisions should be enacted providing that a person who is convicted of the murder, culpable homicide or manslaughter of the deceased by a criminal court in the British Islands or a court-martial should automatically forfeit his or her rights of succession to the deceased's estate and rights to property held in trust devolving on the deceased's death. Where the conviction was that of a foreign court, forfeiture should result if the crime committed would have amounted to murder or culpable homicide had it been committed in Scotland.**
- (b) The common law principle that an unlawful killer should not receive any benefit from the crime should be retained for cases where there is no conviction or where rights other than rights of succession to the deceased victim's estate or rights to property held in trust are concerned.**
- (c) No crimes other than murder, culpable homicide or manslaughter, or analogous crimes committed abroad should give rise to forfeiture or otherwise affect Scottish succession rights.**
- (d) The Parricide Act 1594 should be repealed.**

(Clause 19 and Schedule 2)

Effect of forfeiture

7.15 Clearly the effect of forfeiture should be to disentitle the killer from succeeding to the deceased in any way, whether under the terms of the deceased's will or nomination, on intestacy, by way of legal share, or under a gift by a third party destined first to the deceased and then to the killer. If the killer forfeits the rights of succession what is to happen to them? The Parricide Act 1594 directs that the slayer and his or her descendants are disinherited and the next collaterals and nearest in

1. Para 2.10.

blood succeed instead. The effect of the common law rule is not clear, but it is probably to deem the killer to have predeceased the deceased.¹

7.16 The scheme of the 1594 Act, disinheritance of slayer and issue and succession by next of kin, cannot be applied to all rights of succession. It would work if the deceased died intestate, but could produce absurd results in the case of testamentary provisions and nominations. It does however raise a crucial issue, the effect of forfeiture on the killer's issue. In memorandum 71 we proposed that the issue should not share in the killer's forfeiture, unless of course they had been implicated in the crime and convicted either as principals or art and part.² All those who commented agreed, although one body expressed some concern that the killer could benefit indirectly. For example, a daughter kills her father and his estate passes to the daughter's only child instead of the daughter. Soon afterwards the child dies unmarried, intestate and without issue with the result that the daughter inherits at least half her father's estate.³ Alternatively the child may give the property received from his grandfather's estate to his mother (the daughter), during life or by will. We appreciate the concern expressed, but the problem is not confined to issue. Any alternative beneficiary could give the property to the killer or die leaving the killer as the beneficiary. Moreover, in most cases the issue will have been entirely innocent of their ancestor's crime. We think it would be unjust to penalise them by depriving them of their rights of succession to which they are entitled on the killer's forfeiture, or to prevent them from giving or bequeathing the property to the killer if that is what they wish to do.

7.17 In view of our recommendation that the killer's issue should not be tainted by their ancestor's forfeiture, it becomes possible to provide for the effect of forfeiture by a simple general provision to the effect that the killer is deemed to have predeceased the deceased for the purposes of succession to the deceased's estate and trust property. All those who commented on our proposal to this effect⁴ in memorandum 71 agreed. The following examples illustrate how this provision would work.

- (a) A husband kills his wife who leaves no will. Her estate is distributed under the intestacy rules on the basis that the husband predeceased.
- (b) A wife kills her husband whose will leaves all his estate to her. The estate is intestate because the wife is deemed to have predeceased the testator. It is distributed under the rules of intestacy on the basis that the wife predeceased.
- (c) A husband kills his wife. His wife leaves her whole estate to her sister. The husband is not entitled to claim spouse's legal share because he is deemed to predecease.
- (d) A wife kills her husband. He leaves his estate to her, or to a named charity if she fails to survive him for 30 days. The wife's forfeiture enables the charity to succeed.
- (e) A married son with children kills his mother. Her will leaves a large legacy to him with the residue to her daughter. The son's forfeiture prevents him succeeding. His children will take the legacy he would have taken had he succeeded.⁵
- (f) A man creates a trust in terms of which he receives the income of the fund while alive. On his death the trust fund is to be divided among his three children. He is killed by one of his children who has no family. The trustees divide the fund between the other two children.

7.18 As the deemed predecease of the killer is only for the purposes of succession to the estate of the deceased, there is no problem in the case of property held in common by the killer and the deceased with a destination to the survivor. The killer

1. There are no reported Scottish decisions, but this is the position in England and Wales, although not without some judicial hesitation, *Re Callaway (deceased)* [1956] 2 All ER 451.

2. Para 2.14.

3. Depending on whether the daughter's husband is still alive, Succession (Scotland) Act 1964, s 2.

4. Para 2.14. The proposal was limited to rights of succession.

5. Under the *conditio si institutus* or our recommended replacement (Clause 17).

would forfeit the deceased's share which would have passed to him or her on the death of the deceased, but his or her own share would not pass to the deceased's estate, because that has nothing to do with succession to the estate of the deceased. We recommend that:

35 An unlawful killer who incurs forfeiture should be treated for the purposes of succession to the deceased's estate and any destination of trust property as having predeceased the deceased. Any descendants of the unlawful killer should be entitled to make the same claims on the killer's presumed predecease by virtue of forfeiture as they could have made had the killer actually predeceased without having incurred the penalty of forfeiture.

(Clause 19(2))

7.19 Where the killer's forfeiture is established before the executors distribute the estate, they will simply distribute the estate to those entitled to it on the basis of the killer's deemed predecease of the deceased. The killer's crime may, however, come to light and he or she may incur forfeiture after the estate has been wound up. Those who become entitled to the estate on the killer's forfeiture would then be entitled to recover the property or its value from the killer under the ordinary principles of unjustified enrichment. Trust property distributed to the killer in good faith is in a similar position. Restoration of property with a documentary title vested in the killer would require signature by the killer of the necessary document of transfer, such as a disposition for heritable property or a transfer form for shares, but the killer may refuse to sign. The Court of Session has power at common law to authorise a clerk of court to sign documents on behalf of people who refuse to sign when under a legal obligation to do so¹ and the sheriff has a similar power by statute.² However, the sheriff's powers are limited to documents relating to heritable property where an action relating to the property is before the court or the court has already granted a decree relating to such property. An application to the Court of Session is by way of petition under the *nobile officium* to the Inner House. It would be advantageous to have a simple statutory procedure available in the Outer House of the Court of Session or the sheriff court to deal with recalcitrant killers. We so recommend.

36 There should be a new statutory provision empowering the Court of Session or a sheriff court to authorise a clerk of court to sign any document required to give effect to forfeiture on behalf of a person who refuses or fails to sign.

(Clause 19(6))

7.20 A further complication may arise in that prior to forfeiture the killer may have disposed of property received from the deceased's estate or a trust. Third party transferees who acquired in good faith and for value should not be prejudiced by the killer's subsequent forfeiture and the Keeper of the Registers of Scotland should not be bound in these circumstances to indemnify³ the deceased's estate or the trustees who suffer loss because of the Keeper's refusal to rectify the Land Register by deleting the third party transferees. On the other hand those who acquire property from the killer having knowledge of the forfeiture or by way of gift or succession should be required to restore the property or its value, as otherwise it would be easy for the killer to circumvent the effect of forfeiture. We recommend that:

37(a) A person who has, in good faith and for value, acquired title to property or any interest in property from a person who has forfeited or subsequently forfeits that property or interest should have his or her title protected from challenge.

(b) Where the estate of the deceased or a trust suffers loss as a result of such protection the Keeper of the Registers of Scotland should not be required to indemnify it under the Land Registration (Scotland) Act 1979.

(Clause 19(3) and (4))

Relief from forfeiture 7.21 The Forfeiture Act 1982 (a United Kingdom statute) empowers a civil court

1. *Lennox* 1950 SC 546; *Boag* 1967 SC 322.

2. Sheriff Courts (Scotland) Act 1907, s 5A (introduced by Law Reform (Miscellaneous Provisions)(Scotland) Act 1985, s 17.)

3. Land Registration (Scotland) Act 1979, s 12.

to grant relief from forfeiture incurred by virtue of the common law rule precluding an unlawful killer (except a murderer) from acquiring a benefit in consequence of the killing. In memorandum 71 we stated that in view of the recent date of the legislation we did not wish to question the principle of relief.¹ Only one commentator expressed opposition to the availability of discretionary relief. The legislation has already been used in several Scottish cases.² We made several criticisms of the Act's provisions but many of those have been met by our previous recommendations on forfeiture. Two, however, remain.

7.22 Section 2(5) of the 1982 Act provides:

“An order under this section may modify the effect of the forfeiture rule in respect of any interest in property to which the determination referred to in subsection (1) above relates and may do so in either or both of the following ways, that is:

- (a) where there is more than one such interest, by excluding the application of the rule in respect of any (but not all) of those interests; and
- (b) in the case of any such interest in property, by excluding the application of the rule in respect of part of the property.”

We pointed out that the court is apparently empowered to grant only partial relief. This view was in fact taken by Lord Cowie in the subsequent case of *Cross, Petr.*³ Lord Cowie achieved the result of giving virtually total relief by giving relief in respect of all the heritable property and 99% of the moveable property. Given that the power to grant relief is discretionary, we think that the court should be able to grant total relief in an appropriate case.

7.23 Section 2(3) provides that, where the applicant has been convicted of the unlawful killing, any application to the court for relief under the section must be made within 3 months of the date of the applicant's conviction. Criticism has been voiced at the shortness of the period.⁴ A balance has to be struck between allowing sufficient time for a convicted person to obtain legal advice and instruct an application for relief and not holding up the distribution of the deceased's estate. Executors would be taking a risk if they were to make a distribution on the basis of the forfeiture without waiting for the period for an application for relief to expire. In memorandum 71 we invited views on whether six months was a more appropriate period.⁵ One body thought 3 months was sufficient, while another preferred at least a year or perhaps more bearing in mind possible inheritance tax implications arising from forfeiture or relief. All the other commentators agreed with the 6 month period we suggested. We would adhere to our original proposal especially as the applicant may have been convicted and be imprisoned abroad. We are not in favour of further extending the period to allow sufficient time for tax mitigation schemes. In memorandum 71 we asked whether, where the succession opens to the killer some considerable time after his or her conviction, any time limit should run from the opening of the succession rather than the date of conviction.⁶ Cases could be figured where the killer had only a remote chance of succession when convicted and so did not bother to seek relief but the succession opened to him or her well after the 6 month period allowed for making an application for relief expired. While most of those who commented agreed with our proposal, we have come to the view that the disadvantages in having more complex provisions and further delay in winding up estates outweigh the benefits, especially as a situation where the proposal would be of use would hardly ever arise.

7.24 The need for relief arises not only in cases where forfeiture results from the fact of conviction but also where it results from the common law rule in the absence of conviction. In such cases the present law provides for no time limit on an application for relief. We recommend no change in this respect.

1. Para 2.15.

2. *Paterson, Petr* 1986 SLT 121; *Cross, Petr* 1987 SLT 384; *Jackson, Petr* 1989 Greens Weekly Digest 947.

3. 1987 SLT 384.

4. 1986 SLT (News) 81 by the solicitors acting for the petitioner in *Paterson, Petr* 1986 SLT 121.

5. Para 2.18.

6. Para 2.18.

7.25 When granting relief the court should have power to make any necessary ancillary or consequential orders. For example, the executors could be interdicted from distributing the estate away from the now relieved killer, or recipients of property could be ordered to hand it back to the executors so that it can be made over to the killer. However, persons who had acquired property in good faith and for value should not be required to hand it back and the court should not have power to make such an order. The feasibility and desirability of any "unscrambling" required to give effect to relief would no doubt be a factor which the court would bear in mind in deciding whether, or to what extent, to grant relief.

7.26 The 1982 Act does not permit the court to grant relief where forfeiture results from a conviction of murder.¹ We have recommended that forfeiture should result automatically not only from convictions by courts in the British Islands but also by foreign courts. We do not think it would be right to exclude from relief all persons whose foreign convictions bore to be for murder. Some countries label as murder what in Scotland would amount to culpable homicide. The Scottish civil court hearing the application for relief should take into account the exact nature of the crime in deciding how to dispose of the application. We wish to stress, however, that we are not suggesting any change of policy as far as convictions of murder in courts in the British Islands or British courts-martial are concerned. Accordingly relief should continue to be unavailable for forfeiture resulting from such a conviction.

7.27 We recommend that:

- 38(a) The Scottish civil courts should continue to have power in appropriate cases to grant relief from forfeiture, but where a person is convicted of murder by a court in the British Islands or a British court-martial an application for relief should be incompetent.**
- (b) An application for relief from forfeiture, in a case where the killer has been convicted, should be required to be made within 6 months from the date of the conviction giving rise to forfeiture. Any period during which the conviction may be appealed or is under appeal should not count towards the 6 month period.**
- (c) In granting an application for relief the court should have power to make any necessary ancillary or consequential orders.**

(Clause 20)

The separated spouse

7.28 As a result of our recommendations in Part II the rights of a surviving spouse on intestacy will be substantially improved. Also in many estates the amount a spouse could claim under the new legal share scheme will be greater than what he or she would receive by way of existing legal rights. Should a spouse who had lived apart from the deceased for many years before death be treated as generously as a spouse who had continued to live with the deceased? Separation has no effect on a surviving spouse's succession rights under the present law,² except that property a wife acquires after she has obtained a decree of judicial separation does not pass to her husband if she dies intestate.³ There is no equivalent rule for husbands.

7.29 In memorandum 69 we put forward various options for reform.⁴ The first option was that after a decree of judicial separation neither spouse should have any legal rights or rights of intestate succession in the other's estate. The second option was similar but based on factual separation rather than a decree. A spouse who had lived apart from the other for 7 or more years immediately preceding the other's death should not be regarded as a spouse for the purposes of succession to the

1. S 5.

2. Unless of course the deceased's will or the couple's separation agreement expressly deals with the position.

3. Conjugal Rights (Scotland) Amendment Act 1861, s 6.

4. Para 3.40.

deceased's estate. The third option, recognising the somewhat arbitrary nature of a 7 year period, gave the court a discretion to disapply the rule and restore a spouse to his or her succession rights. The fourth option was entirely discretionary. In terms of this a court could disinherit wholly or partly a spouse who had been separated for any period prior to the deceased's death. The fifth and final option was that separation should have no effect whatsoever on succession rights. Only termination of the marriage by divorce or annulment should bring a spouse's legal rights and rights on intestacy to an end. In our pamphlet¹ we asked for views on whether separation should have any effect on the share a surviving spouse should get on intestacy.

7.30 Consultation revealed no support for the idea that a court should have the power to disinherit a spouse. As we pointed out, such a solution would be unprincipled in that it would apply only to spouses, render the distribution of estates of married couples who had separated uncertain, and give rise to particularly unpleasant litigation. We have no hesitation in rejecting it. Another discretionary scheme was suggested by a commentator. It was to the effect that a spouse who had been separated from the deceased for at least two years preceding death should be entitled to what he or she would have got on divorce under the principles of fair sharing of matrimonial property and fair recognition of certain economic advantages and disadvantages.² The entitlement would be satisfied by an order for a lump sum or a transfer of property. While this scheme would to some extent equiparate the amount received by a spouse whose marriage is terminated by divorce with that received by one whose marriage is terminated by death, its discretionary nature would result in much uncertainty and litigation.

7.31 Most of the organisations who commented were not in favour of separation (whether factual or after a decree) having any effect on succession rights, although if such were to be the case, the option of making disinheritance depend on a fixed period of living apart enjoyed some support. About half the individual respondents, however, expressed support for a period of living apart cutting off a spouse's rights, with the suggested period ranging from 1 to 5 years. If such a solution were to be adopted the period should be somewhat longer than the period required to ground an action for divorce on the basis of non-cohabitation of the spouses without consent being required from the other spouse,³ otherwise a spouse who was unable to seek financial provision from the other by divorce could be disentitled from obtaining provision by way of succession. A fixed period of separation would go a long way towards preventing the hard cases that can occur at present. For example, a spouse who deserted the other many years ago may suddenly turn up and inherit the whole estate on intestacy to the prejudice of children who had been looking after the deceased in his or her last years. But there are many disadvantages of a fixed period of separation affecting succession rights. Firstly, any period would be arbitrary and cases would arise where the death occurred just before or after its expiry, producing unjust results. The further option of empowering the court to restore the rights of a spouse who had been separated for more than the required period provides flexibility, but at the price of uncertainty and litigation. Secondly, there would be practical and evidential difficulties in deciding whether the required period of separation had been met. The disintegration of a marriage can rarely be pinned down to a precise date. Allowances may have to be made for periods of cohabitation with a view to reconciliation occurring after the initial separation.⁴ Thirdly, it would be unfair on the loyal spouse of a long term prisoner, or a deserted spouse who remained in the matrimonial home hoping against hope that the other would return. Finally, spouses who live apart and do not wish the other to inherit their estates have to some extent the remedy in their own hands, in that they can make a will excluding the other spouse. This would restrict the other's rights to the legal share (30% of the estate at the most). We have come to the view, not without some difficulty, that the complexity and arbitrariness of a rule based on a fixed period of living apart outweighs its usefulness.

1. Question 5.

2. Family Law (Scotland) Act 1985, s 9(1)(a) and (b).

3. Divorce (Scotland) Act 1976, s 1(2)(e).

4. Divorce (Scotland) Act 1976, s 2(4).

7.32 The idea that judicial separation should result in the surviving spouse losing his or her legal rights and rights on intestacy also enjoyed some support from those commenting. Judicial separation is not widely used now that divorce has become easier and cheaper and aliment can be obtained before divorce without a decree of judicial separation. Judicial separation results in an empty marriage because the spouses remain married in law but lead separate lives in fact. In memorandum 69 we thought that new life should not be breathed into an obsolescent remedy by giving it new legal effects.¹ We remain of this opinion. However, we recognise that many couples who have been judicially separated will have arranged their affairs on the basis of the existing law, in terms of which property acquired by a wife after judicial separation does not pass to her husband on intestacy. We would therefore retain this rule for decrees of separation obtained before the commencement of legislation implementing our recommendations.

7.33 The solution we have come to favour is that separation of any kind should in future have no effect on the succession rights of spouses. This solution has the great advantages of being clear-cut and simple. It was the preferred solution of most of those organisations who commented. The present 5 year period of living apart required to obtain a divorce without the other spouse's consent or matrimonial offence may well be reduced in the near future² if this were to happen the disadvantages of this simple solution would be lessened because a separated spouse could, after a relatively short period, disinherit the other by divorce. We therefore recommend that:

- 39(a) Separation (whether or not a decree of judicial separation has been obtained) should by itself have no effect on the succession rights of spouses in each other's estates.**
- (b) Section 6 of the Conjugal Rights (Scotland) Amendment Act 1861 should accordingly be repealed, but without prejudice to the effect of existing decrees.**

(Schedule 2)

1. Para 3.36.

2. In our report on *Reform of the Ground for Divorce* (Scot Law Com No 116, 1989) we have recommended that this period should be reduced to two years.

Part VIII Executory Questions

Introduction

8.1 In this part of our report we deal with a number of issues relating to executors, confirmation and the distribution of executry assets. We intend to examine the law of executors and administration of estates, in particular the transmission of debts on the death of the debtor, in a future exercise.

Spouse's right to acquire home and furnishings

8.2 Under the present law the surviving spouse is entitled to the deceased's interest in the house and furnishings if they are intestate estate. This entitlement is part of the spouse's prior rights but is subject to a number of exceptions.¹ Earlier in this report we set out criticisms of the present system of prior rights and recommended that where the deceased is survived by a spouse and issue the spouse should be entitled to all or the major part of the estate depending on its size.² Under such a scheme the spouse has simply a right to money rather than specific assets. In memorandum 69 we proposed³ that on intestacy if the surviving spouse did not have a right to the deceased's interest in the home and contents as such, he or she should be given the option to be allocated them in satisfaction of his or her rights on intestacy. If the value of the assets exceeded the spouse's intestate rights, he or she should still be entitled to acquire them on payment of the excess to the estate.

8.3 All those consulted were in favour of our proposal. Many commented that surviving spouses should not be faced with the possibility of having to move house in addition to the other problems brought about by bereavement. We agree with these views. In many cases the entitlement to purchase would not arise. The surviving spouse would inherit the whole estate if the deceased left no issue, or if the estate was less than £100,000 in value. The executor would simply transfer all the estate including the deceased's interest in the home and contents to the surviving spouse. Some reservations were expressed about very valuable ancestral homes. We are not in favour of putting an upper limit on the value of the home that could be acquired by the surviving spouse. Any particular figure would be arbitrary and difficult to justify to disappointed spouses. Heirlooms are currently exempted from the surviving spouse's prior rights. They are defined as:

“any article which has associations with the intestate's family of such nature and extent that it ought to pass to some member of the family other than the surviving spouse of the intestate.”⁴

As far as we are aware the exclusion of heirlooms has not caused any problems over the many years since the 1964 Act was passed and we think they should be excluded from the spouse's entitlement to purchase.

8.4 The 1964 Act also excludes from the spouse's prior right a home which is part of leasehold subjects or is part of a larger business property whose value would be substantially diminished by separating the home from the rest of the property. In these cases the spouse is entitled to the value of the home in money up to a certain

1. Succession (Scotland) Act 1964, s 8.

2. Para 2.5.

3. Para 3.23.

4. Succession (Scotland) Act 1964, s 8(6)(c).

limit rather than the home itself.¹ These exclusions should, we think, also apply to the spouse's entitlement to purchase.

8.5 Under the 1964 Act a surviving spouse is entitled to the deceased's interest in the house if ordinarily resident there at the date of the deceased's death.² This test can lead to harsh results. A surviving spouse driven from the home by domestic violence would not have been ordinarily resident there, nor would a surviving spouse where the couple were in the process of moving into a new home. The Matrimonial Homes (Family Protection)(Scotland) Act 1981 defines³ a matrimonial home as:

“any house, caravan, houseboat or other structure which has been provided or has been made available by one or both of the spouses as, or has become, a family residence and includes any garden or other ground or building attached to, and usually occupied with, or otherwise required for the amenity or convenience of, the house, caravan, houseboat or other structure but does not include a residence provided or made available by one spouse for that spouse to reside in, whether with any child of the family or not, separately from the other spouse.”

This we think achieves the right connection between the surviving spouse and the home to be acquired. It would allow a spouse to purchase the home in the two cases mentioned above, but would prevent a spouse from purchasing the home which the deceased had bought for his or her own occupation after a separation.

8.6 Where the deceased's estate includes two or more matrimonial homes, we think the spouse should be allowed to choose which (if any) he or she wishes to purchase. The entitlement to purchase furnishings should be similarly restricted but the choice of furnishings should not be tied to the choice of house.

8.7 Other situations besides intestacy could arise in which an option to purchase the matrimonial home and contents should, in our view, be conferred on the surviving spouse. The widespread use of survivorship destinations in titles to dwellinghouses amongst married couples, means that the surviving spouse would automatically inherit the home in most cases. But where there is no survivorship destination, the spouse might simply be the residuary beneficiary or one of the residuary beneficiaries with the home and contents forming part of the residue. The surviving spouse although vested in the residue or a share of residue, has no right to any of the assets of the estate as such until the executors transfer them to him or her.⁴

8.8 We recommend that:

- 40(a) A surviving spouse who is entitled to a share of intestate estate which includes the deceased's interest in the matrimonial home and furnishings should be given an option to acquire the deceased's interest in them, in satisfaction or part satisfaction of his or her entitlement. Where the value of the interest exceeds the value of the spouse's entitlement on intestacy, the spouse should still be entitled to acquire on paying the excess to the estate.**
- (b) A similar option should be given to a surviving spouse where the home or furnishings are part of the residue of the estate of which the spouse is a beneficiary.**
- (c) There should be no option to acquire where the home is part of property tenanted by the deceased, or where the home is part of a larger business property whose value would be substantially diminished by splitting off the home.**
- (d) Where the estate includes an interest in more than one matrimonial home and furnishings, the surviving spouse's option to acquire should be limited to one home and one set of furnishings. The spouse should be entitled to elect which home and furnishings (not necessarily in the home sought to be acquired) he or she wishes to acquire.**

1. 1964 Act, s 8(1) and (2).

2. 1964 Act, s 8(4).

3. S 22.

4. *Cochrane's Exs v Inland Revenue* 1974 SC 158.

(e) **The surviving spouse should have no option to acquire heirlooms of the deceased's family.**

(Clause 23)

Time limits on spouse's option to acquire

8.9 In order to prevent executries being unduly delayed there has to be a time limit placed on the surviving spouse's option to acquire the home and furnishings. The limit should run from confirmation because only then is the extent and value of the deceased's estate fully known, so giving the surviving spouse sufficient information to decide whether or not to exercise the option. A period of 6 months from confirmation seems to strike the correct balance between avoidance of undue delay and giving the spouse sufficient time. This time limit is of course a maximum. In many cases the surviving spouse will reach a decision without waiting for confirmation.

Valuation of items

8.10 How and at what date should the home and furnishings be valued? We do not think the surviving spouse should be entitled to acquire at the date of death value as set out in the inventory of the estate. First, the inventory value of heritage is usually an estimate, adjusted later with the Inland Revenue. The value placed on furnishings is even more rough and ready; often the whole household contents are entered as a single item at some fairly nominal figure unless the deceased owned particularly valuable furnishings.¹ Secondly, the surviving spouse may exercise the option months, or where pre-confirmation investigations have taken a long time, even years after the deceased's death. In times of rapid increase in house prices, use of the date of death value would allow the surviving spouse to acquire executry assets at a substantial discount, to the prejudice of other beneficiaries.

8.11 We would hope that in most cases the surviving spouse, the executors and other beneficiaries would be able to agree an acquisition value. The other beneficiaries should be restricted to those whose share in the estate is affected by the acquisition value. In the case of intestacy, the other beneficiaries are the deceased's issue; where the deceased left a will, they are the residuary beneficiaries and any issue who have claimed legal share. Special and general legatees are unaffected by the value at which the surviving spouse acquires the home and furnishings. Under the Succession (Scotland) Act 1964 any dispute about the value of the home and furnishings for the purposes of prior rights is settled by arbitration by an arbiter appointed by the parties or failing agreement, by the sheriff principal of the sheriffdom in which the deceased died domiciled.² We would adopt this procedure for setting the acquisition value when those concerned failed to agree. The remit of the arbiter would be to set the value at the date of the surviving spouse's intimation of his or her intention to acquire.

Procedure

8.12 The procedure of acquisition would start with the surviving spouse intimating to the executors his or her intention to acquire the home or some or all of the furnishings. Where the surviving spouse is the sole executor, intimation should be given to the other beneficiaries whose interests would be affected by the acquisition³, provided that they can be identified and traced after reasonable inquiries have been made. The next step would be for the executors to intimate the spouse's intention to the other beneficiaries unless the spouse had already done this. We would leave to those concerned how they agree a value. Depending on the circumstances, the inventory value might be used, or the executors might arrange for the items to be professionally valued, or the parties may agree some completely different value. The negotiations would take place against the background that in default of agreement an arbiter would set an open market value as at the date of the spouse's intimation.

8.13 An executor who transacts as an individual with the estate is said to be acting *in rem suam*. Such transactions are voidable at the instance of a co-executor or a beneficiary (provided action is taken within a reasonable time) because of the conflicts of interest or potential conflicts of interest between the executor acting in a personal

1. CRU Report on Succession, para 4.9. The average value in 1986/7 was found to be £870.

2. S 8(5) as read with the Sheriff Courts (Scotland) Act 1971, Sch 1, para 1 and the Interpretation Act 1978, Sch 1, "sheriff". Where the sheriffdom is uncertain or the deceased died domiciled furth of Scotland, the appropriate sheriff principal is that of the Lothians and Borders.

3. See para 8.11 above.

capacity and the executor acting in a fiduciary capacity.¹ Even though the transaction was in fact conducted with scrupulous fairness, there is always the suspicion of underhand dealing or "inside" knowledge. In many cases the surviving spouse will be one of the executors, if not the sole executor. An acquisition of the house or furnishings would therefore be *in rem suam*. We consider that the procedures outlined above whereby the acquisition would have to be agreed by all those financially interested, or set by an independent arbiter are sufficient to allay fears of conflict of interest.

8.14 We recommend that:

- 41(a) The surviving spouse should be entitled to acquire the home and furnishings only if he or she intimates an intention to acquire not later than six months after confirmation.**
- (b) Intimation of the intention to acquire should be given by the surviving spouse to the executors, or if the surviving spouse is the sole executor, to all those beneficiaries whose interests in the estate would be financially affected by the value at which the spouse acquired the assets and who can be identified and traced after reasonable inquiries have been made.**
- (c) The acquisition value should be either agreed by the surviving spouse, the executors, and the interested beneficiaries or set by an arbiter. The arbiter should be appointed by agreement or failing agreement by the sheriff principal of the sheriffdom in which the deceased died domiciled. Where the sheriffdom is uncertain or the deceased died domiciled furth of Scotland, the arbiter should be appointed by the sheriff principal of the Lothians and Borders.**
- (d) The arbiter should value the items sought to be acquired at their open market value at the date when the spouse intimated the intention to acquire them.**
- (e) An acquisition of the home or furnishings under the above procedures by a surviving spouse who is an executor or the sole executor, should not be voidable as a transaction *in rem suam*.**

(Clause 23)

Protection of trustees and executors

8.15 Trustees and executors have a duty to distribute the estate to those entitled to it. They are generally liable to the correct beneficiaries if they make payments to those not entitled to receive them.² In order to provide some protection for executors and trustees, section 7 of the Law Reform (Miscellaneous Provisions)(Scotland) Act 1968³ provides:

"A trustee or an executor may distribute any property vested in him as such trustee or executor, or may make any payment out of any such property, without having ascertained—

- (a) that no illegitimate person exists who is or may be entitled to an interest in that property or payment in consequence of any of the said provisions, and
- (b) that no illegitimate person exists or has existed, the fact of whose existence is, in consequence of any of the said provisions, relevant to the ascertainment of the persons entitled to an interest in that property or payment, and
- (c) that no paternal relative of an illegitimate person exists who is or may be entitled to an interest in that property or payment,

and such trustee or executor shall not be personally liable to any person so entitled of whose claim he has not had notice at the time of the distribution or payment;

1. Wilson and Duncan, *Trusts, Trustees and Executors*, pp 361-362.

2. Wilson and Duncan, *Trusts, Trustees and Executors*, p 373.

3. As amended by the Law Reform (Parent and Child)(Scotland) Act 1986, Sch 1 para 10 and Sch 2.

but (without prejudice to section 17 of the Act of 1964)¹ nothing in this section shall affect any right of any person so entitled to recover the property, or any property representing it, or the payment, from any person who may have received that property or payment.”

8.16 Protection also exists as regards adoptions. Section 24(2) of the Succession (Scotland) Act 1964 provides:

“(2) Notwithstanding anything in the last foregoing section, a trustee or an executor may distribute any property for the distribution of which he is responsible without having ascertained that no adoption order has been made by virtue of which any person is or may be entitled to any interest therein, and shall not be liable to any such person of whose claim he has not had notice at the time of the distribution; but (without prejudice to section 17 of this Act) nothing in this subsection shall affect any right of any such person to recover the property, or any property representing it, from any person who may have received it.”

One minor defect of this provision is that executors and trustees are not protected in relation to adoption orders by virtue of which a person ceases to be entitled to an interest in an estate.²

8.17 In memorandum 71 we proposed that these disparate provisions should be reformed and expressed in a general fashion. Protection should exist provided the trustees or executors had acted in good faith and made such enquiries as were reasonable in the circumstances.³ Our proposal was welcomed as a useful general rule by all those who commented. We see three advantages of a general rule. First, it extends the scope of the statutory protection to cases where the entitlement of beneficiaries comes to light later for reasons unconnected with adoption and birth outwith marriage. Secondly, it removes one of the few remaining legal differences between persons whose parents were married to each other and those whose parents were not. Thirdly, it simplifies the law by bringing together a number of separate provisions into one general provision.

8.18 The proposed requirement of good faith on the part of trustees and executors coupled with a duty to make such enquiries as are reasonably necessary in the circumstances would represent at most only a slight change in the law, because it is clear that the liability of trustees and executors to distribute correctly is not absolute.⁴ One commentator suggested that there should be an express duty to advertise in appropriate cases. We agree that advertising may well be necessary in appropriate cases, but the general duty to make all reasonable enquiries encompasses it. An express mention of advertising would give undue prominence to this method of pursuing enquiries. There would be a danger that trustees and executors would feel obliged to advertise even in cases where it would serve no useful purpose. We would stress that, as under the existing law, any provision protecting executors and trustees would not affect the rights of persons entitled to recover property forming part of the estate from those to whom it had been distributed in error. But the right of recovery is, and should continue to be, without prejudice to section 17 of the Succession (Scotland) Act 1964. This provides that the title of a good faith purchaser of heritage⁵ which had been vested in an executor by virtue of confirmation cannot be challenged on certain grounds. We recommend that:

42. A trustee or executor in making a distribution from the estate vested in him or her should not be personally liable for any error in distribution based on ignorance of the existence or non-existence of persons or their relationship or lack of relationship with a relevant person (including relationships by adoption or marriage) provided that he or she acted in good faith and made such enquiries

1. The Succession (Scotland) Act 1964, s 17 protects persons who have acquired title to heritable property in good faith and for value.

2. Wilson and Duncan, *Trusts, Trustees and Executors*, p 375.

3. Para 5.9.

4. Lord Kinloch in *Lamond's Trs v Croom* (1871) 9M 662 at p 671.

5. We discuss the extension of this to moveables in the next paragraph.

as a reasonable and prudent trustee or executor would make in such circumstances.

(Schedule 1, paragraph 7)

Protection of acquirers of executry assets

8.19 Section 17 of the Succession (Scotland) Act 1964 protects persons purchasing heritable property in whom such property is or was vested in an executor by virtue of confirmation. It provides:

“Where any person has in good faith and for value acquired title to any interest in or security over heritable property which has vested in an executor as aforesaid directly or indirectly from—

- (a) the executor, or
- (b) a person deriving title directly from the executor,

the title so acquired shall not be challengeable on the ground that the confirmation was reducible or has in fact been reduced, or, in a case falling under paragraph (b) above, that the title should not have been transferred to the person mentioned in that paragraph.”

Protection as regards moveables is provided by section 23 of the Sale of Goods Act 1979.

“When the seller of goods has a voidable title to them, but his title has not been avoided at the time of sale, the buyer acquires a good title to the goods, provided he buys them in good faith and without notice of the seller’s defect of title.”

8.20 In memorandum 71 we pointed out that the above provisions seemed deficient in at least two respects. First, a purchaser of executry assets such as shares or book debts has no protection under section 17 (since the items are not heritage) or section 23 (since they are not goods¹). Secondly, there is no statutory protection for a person who acquires moveable executry assets in good faith and for value otherwise than by purchase. We proposed that, without prejudice to the additional protection provided by section 23 of the 1979 Act, section 17 of the 1964 Act should extend to acquirers of all types of property.² This proposal was agreed by all those who commented. In other similar areas no distinction is drawn between heritage and moveables. For example, section 2 of the Trusts (Scotland) Act 1961, as read with section 4(1)(a) of the Trusts (Scotland) Act 1921, protects persons who purchase from trustees any part of the trust estate, heritable as well as moveable, from any challenge on the ground that the sale was at variance with the terms or purposes of the trust. Protection should be extended to persons acquiring for value in good faith otherwise than by way of purchase. It is not uncommon for persons with interests in an estate to acquire executry assets which they particularly wish to possess (such as pictures, furniture or shares in the family business) by way of exchange or by foregoing claims which they might have made. Our recommendation³ entitling a surviving spouse to acquire the matrimonial home or furnishings in satisfaction or partial satisfaction of his or her share in the estate may increase the number of acquirers for value who are not purchasers. We recommend that:

43. Without prejudice to section 23 of the Sale of Goods Act 1979 (protection of good faith purchasers of goods for value against seller’s voidable title), section 17 of the Succession (Scotland) Act 1964 should be extended so as to protect persons acquiring (whether by purchase or otherwise) from the executor, or a third party deriving title from the executor, any executry assets in good faith and for value.

(Schedule 1, paragraph 11)

1. S 61(1) of the Sale of Goods Act 1979 defines goods as including corporeal moveables but excluding money.

2. Proposition 25, para 5.11.

3. Para 8.8 above.

Using the will as the link in title

8.21 Section 14 of the Succession (Scotland) Act 1964 vests by virtue of confirmation the deceased's heritable, as well as moveable, property in the executor for the purposes of administration. Section 15 deals with the transfer of such heritage to beneficiaries or persons purchasing from the executor. As read with section 5 of the Conveyancing (Scotland) Act 1924 section 15 of the 1964 Act provides that a confirmation in favour of an executor which includes any interest in heritable property (described in prescribed form)¹ is a valid title to the interest and forms a warrant whereby the executor can deduce title in a subsequent deed conveying the interest to a third party or complete title in his or her own name by way of a notice of title. Section 15 further provides that an executor may transfer any interest vested by virtue of confirmation to the legatee of that interest or to a person in satisfaction of legal rights or rights on intestacy.

8.22 We pointed out in memorandum 71² that while it is accepted that executors or trustees may deduce or complete title to the deceased's heritage via the will instead of confirmation, there is considerable doubt as to whether the legatee of a specific bequest of heritage in a will can competently deduce or complete title, at least where the deceased was infeft.³ In practice neither the Keeper of the Registers of Scotland in examining a title for registration in the Land Register for Scotland nor a purchaser will accept the title with a link via a legatee. We proposed⁴, following the Halliday Committee⁵, that deduction or completion of title via the will should cease to be competent so that confirmation would become the sole method. While a majority of those consulted agreed, three organisations with practical experience of conveyancing were opposed on the grounds of expense of obtaining confirmation and the convenience of using the will. This has led us to reconsider the matter. We now think that there are situations where the availability of an alternative method of deducing or completing title would be useful. In some estates the only asset requiring confirmation is the deceased's house. A legatee could complete title via the will without incurring the expense of confirmation as long as the estate is not liable for inheritance tax.⁶ Another situation is where the executor (or last surviving executor) dies before transferring title to the legatee or before an error in the transfer can be put right. The executor of the deceased's executor could confirm to the item of estate and transfer it to the legatee⁷ but it would be much simpler if the legatee could complete title via the deceased's will. We do not think that making the alternative method of deducing or completing title via the deceased's will competent in all cases will lead to much confusion. Because of the protection afforded by section 17 of the Succession (Scotland) Act 1964 to acquirers taking title from a confirmed executor that will remain the preferred route. Title will be completed via the deceased's will only where that method offers clear advantages. We therefore recommend that:

44. It should continue to be competent for an executor or trustee to use the deceased's will as a link or warrant for deducing or completing title to the deceased's heritage. This facility should be extended to legatees or general disponees under the will.

(Schedule 1, paragraph 4)

1. Ss 14(2) and 15(1) proviso; Act of Sederunt (Confirmation of Executors Amendment) 1966.

2. Paras 5.12-5.15.

3. A beneficiary under a testamentary trust disposition and settlement cannot deduce or complete title via the deed. In the unusual situation where the deceased was uninfeft it seems to be accepted that a special legatee of heritage can deduce or complete title via the deceased's will. See Opinion of the Four Professors of Conveyancing, *Journal of the Law Society of Scotland*, 1965, p 153.

4. Para 5.15.

5. Report of the Committee on Conveyancing Legislation and Practice (Chairman, Professor J M Halliday), (Cmnd 3118, 1966) para 149.

6. The current threshold (1989/90) is £118,000. Where the estate exceeds this figure an inventory is required, which must detail all the deceased's estate.

7. Executors (Scotland) Act 1900, ss 6 and 7.

Appointment of executors-dative

8.23 At common law, the right to succeed on intestacy to moveable estate vested in the surviving members of the class of relatives nearest in degree to the intestate. These nearest relatives were termed next-of-kin. The intestate's spouse, mother and maternal relatives were, however, completely excluded so that the order of next-of-kin was children, grandchildren etc., full brothers and sisters, half brothers and sisters related through the father, father, collaterals of the father, father's parents etc. Those succeeding applied in their capacity as next-of-kin for appointment as executors-dative. The Succession (Scotland) Act 1964 swept away most of the previous rules of succession to moveable intestate estate and replaced them with a statutory list of those entitled to succeed to the free estate—the estate (both moveable and heritable) remaining after satisfaction of the prior and legal rights of the surviving spouse, children and other descendants (if any).¹ In terms of the 1964 Act the executor is vested in the heritable estate as well as the moveable, but this apart, no great change was made to the right to be appointed executor-dative. Section 9(4), restating earlier provisions to the same effect in the Intestate Husband's Estate (Scotland) Acts 1911 to 1959,² provides that where a surviving spouse's monetary prior right exhausts the estate, so that the spouse is entitled to the whole estate, he or she has the right to be appointed executor. Section 5(2) provides, along the lines of an earlier enactment,³ that the right of persons succeeding as representatives of predeceasing next-of-kin to the office of executor is postponed to that of the surviving next-of-kin.

8.24 In memorandum 71⁴ we drew attention to a number of defects in the present law. First, the right to be appointed executor-dative has become divorced from the right to succeed to the intestate estate since next-of-kin retains its common law meaning.⁵ This leads to there being no express statutory rule that persons entitled to succeed are entitled to be appointed executor-dative⁶, and next-of-kin who are not entitled to succeed can probably insist on being appointed executor-dative.⁷ Secondly, next-of-kin (who do not include the spouse, mother and maternal relatives of the deceased) form a sexually biased class reflecting the ideas of a bygone age. We proposed that a statutory successor should have an express title to be appointed executor-dative, and that appointment on the basis of next-of-kin should become incompetent. These proposals were accepted by virtually all those who commented. Two bodies opposed the abolition of the rights of next-of-kin to be appointed but gave no reasons. A justification for enabling a non-succeeding relative to apply is that an executor-dative can then be appointed where those beneficially interested are either unwilling to act or incapable of acting as executor-dative. We think it would be better to deal with this problem in another way without retaining the concept of next-of-kin. We have had helpful discussions with the Depute Commissary Clerk at HM Commissary Office. As a result the solution which we now favour is to permit, in the absence of an application by a beneficiary, any blood relative of the deceased to apply for appointment as executor-dative. Before a non-beneficiary could be appointed the sheriff would have to be satisfied that no beneficiaries intended to apply. We do not envisage that this would require a hearing in uncontested cases. The non-beneficiary relative seeking appointment should be able to lodge documentary evidence such as a letter from the beneficiary declining appointment, a medical certificate stating that the beneficiary was incapax, or a birth certificate showing that the beneficiary was under age. In the unlikely event of a competition between relatives the sheriff should appoint the relative nearest to the deceased, provided he or she was acceptable on other grounds.

1. Ss 1 to 7.

2. Intestate Husband's Estate (Scotland) Act 1919, s 3.

3. Intestate Moveable Succession (Scotland) Act 1855, s 1, repealed by the Succession (Scotland) Act 1964.

4. Paras 5.16-5.21.

5. *Young's Trs v Janes* (1880) 8R 242.

6. Apart from a surviving spouse who inherits the whole estate. It is however accepted commissary practice that statutory successors are entitled to be appointed. In *Muir* (1876) 4R 74 the deceased's mother was appointed as she was a statutory successor under the Intestate Moveable Succession (Scotland) Act 1855, s 4, although not next-of-kin.

7. *Bones v Morrison* (1866) 5M 240.

8.25 We recommend that:

- 45(a) It should cease to be competent to appoint a person as executor-dative to the estate of a deceased person merely on the ground of being within the archaic and restrictive common law definition of “next-of-kin” to the deceased.**
- (b) Any relative of a deceased person should be entitled to apply for appointment as executor-dative to the deceased.**
- (c) For this purpose, a “relative” should mean any person entitled to succeed to the deceased on intestacy or, if no such person is to apply, any blood relative.**
- (d) If more than one relative applies, the sheriff should, unless there is good reason not to do so, appoint the one most closely related to the deceased. Where the applicants are equally closely related the sheriff may appoint one, some or all of them.**

(Schedule 1, paragraph 2)

8.26 Section 1 of the Confirmation of Executors (Scotland) Act 1823 enacts that the right to be confirmed as next-of-kin to the deceased’s intestate moveable estate transfers to representatives where the next-of-kin die before confirmation. The original purpose of this provision was two-fold. First, it changed the common law rule that the right to succeed vested on confirmation and replaced it with the rule that the right vested at the date of the deceased’s death by survivance. Both the Succession (Scotland) Act 1964 and the Bill annexed to this report provide that succession depends upon survivance. They therefore supersede the earlier enactment. Secondly, it gave representatives of next-of-kin who were vested, but who died before confirmation to the deceased’s intestate estate, a title to apply for appointment as executors-dative. It would appear that the provision is also unnecessary for this purpose. In modern practice the representative seeks appointment as executor to the whole estate left by the next-of-kin (including estate due from the deceased’s intestate estate) by virtue of the next-of-kin’s will or an independent right of succession if the next-of-kin died intestate.¹

8.27 In memorandum 71 we proposed that section 1 of the 1823 Act should be repealed.² All those who responded to this proposal were in favour and we recommend that:

- 46. Section 1 of the Confirmation of Executors (Scotland) Act 1823, having been superseded by later enactments and practice, should be repealed.**

(Schedule 2)

Power to issue confirmation where no estate in Scotland

8.28 Where a person dies domiciled in Scotland without any estate situated there, it is not competent for a Scottish court to grant confirmation. The basis of the jurisdiction is the existence of estate in Scotland.³ In memorandum 71 we suggested that jurisdiction to confirm executors to domiciled Scots should be conferred even in the absence of any Scottish estate.⁴ This suggestion was approved by all those who commented on it. We think the change would assist executors living in Scotland in that they could obtain a title to the estate more easily by means of familiar Scottish procedure instead of having to apply to the jurisdiction (or jurisdictions) where the deceased’s assets are situated. We recommend that:

- 47. Jurisdiction should be conferred on Scottish courts to grant confirmation to executors of a person who died domiciled in Scotland, even where there is no estate situated in Scotland.**

(Clause 21 and Schedule 2)

1. Wilson and Duncan, *Trusts, Trustees and Executors*, p 431.

2. Para 5.21.

3. Anton, *Private International Law*, p 489.

4. Para 5.23.

Partial confirmation

8.29 In Scotland the rights of beneficiaries in the deceased's estate generally vest in them by survivorship. The title to the various assets, however, generally vests in the executors by virtue of confirmation.¹ In order to obtain confirmation executors are required to submit a full inventory.² This requirement means that in complex estates there is nobody having a title to the deceased's assets for months or even years after death. In memorandum 71 we expressed the view that this lack of title may prevent executors disposing of assets prior to confirmation and may result in loss to the estate.³ A quick sale may be highly desirable in the case of shares whose value is falling rapidly or unoccupied heritable property. To elicit views on the scale of the problem we suggested that it should be possible to obtain confirmation to part of the estate on special cause shown, either by allowing confirmation to specified assets or by removing the need for a full inventory.

8.30 There was a division of opinion on consultation. Although most were in favour of our suggestion there was opposition from some of those concerned with executries in practice. The arguments advanced against introducing partial confirmation were:

- (a) The problems flowing from the requirement to submit a full and complete inventory are not sufficiently acute. Assets whose value is difficult to ascertain can be entered at an estimated provisional value and corrected later, along with any other errors or omissions, by means of a corrective or additional inventory.
- (b) The Inland Revenue's tax gathering capacity would be prejudiced. At present inheritance tax due on the estate as disclosed in the inventory must be paid before confirmation can be obtained. Partial confirmation might lead to a considerable delay in submitting an inventory to the remainder of the assets and hence paying the balance of the tax, since the executors by obtaining a title to assets which required to be dealt with urgently, would be under no pressure to get confirmation to the other assets.
- (c) There was a danger that many executors would consider their need for confirmation to be urgent and seek partial confirmation. Applications would require to be heard by a sheriff and would therefore further burden the courts.
- (d) Partial confirmation might lengthen the period of administration of estates if executors delayed in obtaining confirmation to the balance of the estate after being confirmed to most of it.

8.31 It would be possible to meet some of the objections by making the granting of partial confirmation subject to conditions or undertakings from executors to submit an inventory for the balance of the estate within a specified time or lodge sums to account of future tax liabilities. The result would inevitably be a more complex procedure. In view of the disadvantages set out in the last paragraph and in the absence of any clear demand for partial confirmation we do not recommend the introduction of partial confirmation.

Requirement on executors to find caution

8.32 A bond of caution is an obligation by a third party (in modern practice normally an insurance company⁴) to indemnify any creditor or beneficiary of an estate against loss caused by maladministration, negligence or fraud on the part of the executor. Bonds of caution provide protection in those cases where suing the executor would not be an effective remedy.

1. Succession (Scotland) Act 1964, s 14.

2. Probate and Legacy Duties Act 1808, ss 38 and 42.

3. Para 8.15.

4. Personal cautioners are commoner in small estates (estates whose gross value does not exceed £17,000—Confirmation to Small Estates (Scotland) Act 1979 as amended). Evidence of a personal cautioner's financial status is required before his or her bond is accepted.

8.33 At present most executors-dative,¹ but not executors-nominate, are required to find caution before they are confirmed. The arguments for abolition of the requirement are as follows:

- (a) The estate is put to extra expense in obtaining a bond of caution. The normal premium ranges from £1.20 to £2.00 per £1,000 so that for an estate having a gross value of £20,000 the cost would be between £24 and £40. We understand that insurance companies decline to act as cautioners for executors acting on their own unless the estate is small and its administration is straightforward, so that a solicitor may have to be employed to administer the estate in order to obtain caution.
- (b) Claims under bonds of caution are relatively rare so that all intestate estates are put to expense in order to protect a small number of people. Furthermore, the protection provided by a bond of caution is not complete since a claim under the bond may be repudiated by the cautioner² or may not cover the whole estate administered by the executor.³

On the other hand there are considerations which favour retaining a general requirement for executors-dative to find caution.

- (a) Claims under bonds of caution do arise from time to time. In the absence of a bond those suffering loss might well be left without any effective remedy.
- (b) Caution provides valuable protection for minor beneficiaries in that insurance company cautioners take steps where possible to ensure that the funds are securely invested on behalf of the minor until he or she comes of age.
- (c) The court has power to restrict the amount of caution required where the caution for the full gross value of the estate would be excessive. The expense of an application is, however, usually more than the reduction in premium.

8.34 In memorandum 71 we suggested that the requirement on executors-dative (other than surviving spouses who inherit the whole estate by virtue of prior rights) to find caution serves a useful purpose and proposed its continuation.⁴ Most of those who commented were in favour of retaining caution. One body thought caution should be abolished but gave no reason. We therefore make no recommendation for any change in the rule that executors-dative are required to find caution.

8.35 Prior to 1823 executors-nominate as well as executors-dative were required to find caution for the full value of the estate confirmed to. Section 2 of the Confirmation of Executors (Scotland) Act 1823 removed the requirement to find caution from executors-nominate who are now required to find caution only in exceptional circumstances.⁵ If caution is to be retained it might be thought that it should be required from all executors, whether nominate or dative. It may be said that the need to protect creditors and beneficiaries arises in both testate and intestate estates. Furthermore, executors-nominate, unlike executors-dative, frequently have no beneficial interest in the estate and so have no personal financial interest in its proper administration. On the other hand, people making wills select executors in whom they have confidence and usually appoint at least one person familiar with business or financial matters in order to ensure proper administration of the estate. We proposed in memorandum 71 that the existing rule should continue.⁶ This proposal met with almost universal approval, but one commentator suggested that caution should perhaps be required from assumed executors. We do not favour such an innovation. Although assumed executors are not chosen by the deceased, they can be presumed to have been selected by the other executors on the basis of their probity and experience. We accordingly make no recommendation for change in the rule whereby executors-nominate are not required to find caution.

1. A surviving spouse who inherits the whole estate by virtue of prior rights does not require to find caution before confirmation as executor-dative, Law Reform (Miscellaneous Provisions)(Scotland) Act 1980, s 5, amending Confirmation of Executors (Scotland) Act 1823, s 2.

2. *Harrison v Butters* 1969 SLT 183.

3. See para 8.36 below.

4. Para 5.31.

5. Currie, *Confirmation of Executors*, p 94.

6. Para 5.32.

8.36 Section 2 of the Confirmation of Executors (Scotland) Act 1823 provides that the sum for which a bond of caution is required is to be fixed by the court. The current practice is that unless judicially restricted caution is required for the full gross value of the estate in the inventory.¹ This reduces the protection offered by the bond if there are other items of estate which are administered by the executor, though not confirmed to. Examples of such other items include:

- (a) estate situated outwith the United Kingdom;
- (b) estate which the deceased was administering as a trustee or executor and to which his or her executor acquires title by appending a note of the trust estate to the inventory;² and
- (c) a lump sum payment from the trustees of the deceased's superannuation scheme.

An executor is just as likely to commit embezzlement or an error of administration in respect of these items as he or she is in respect of estate confirmed to.³ In order to protect creditors and beneficiaries fully we proposed in memorandum 71 that the bond of caution should be for the full gross value of the estate to be administered by the executor, unless the court substitutes a lower sum.⁴ All those who commented were in agreement, and we adhere to our proposal. If this change were to be implemented rules of court would be needed requiring an executor-dative seeking confirmation to disclose all items which he or she will administer but which are not included in the inventory. The Law Society of Scotland suggested that where the executor was one of the beneficiaries (as is almost always the case) caution should be restricted to the full gross value passing to the other beneficiaries. We discuss restriction of caution in the following paragraphs but meanwhile recommend that:

48. Unless the court allows a restriction of caution, the sum for which a bond of caution should be granted should be the full gross value of the estate to be administered by the executor.

(Schedule 1, paragraph 1)

8.37 One of the disadvantages of caution is that the expense of a bond of caution is considerable. In memorandum 71 we put forward two suggestions for dispensing with caution or restricting the amount. Section 5 of the Law Reform (Miscellaneous Provisions)(Scotland) Act 1980 provides that where the surviving spouse inherits the whole estate by virtue of prior rights, he or she does not require to find caution, on the basis that protection is not required where the beneficiary and the executor are the same person. We suggested caution should also be dispensed with in other cases where the beneficiaries are also the executors.⁵ Another suggestion was that the court should be empowered to dispense with caution where all the beneficiaries consented or to restrict it to the amount of the estate due to non-consenting beneficiaries where not all of the beneficiaries consented to caution being dispensed with.⁶ Both of these suggestions were generally approved on consultation, although certain disadvantages were pointed out. The Regional Sheriff Clerks suggested a completely different approach to caution whereby a universal bond of caution covering all executors-dative would be taken out every year by Scottish Courts Administration or another appropriate authority. The premium would be recovered from individual executors-dative confirmed in that year, perhaps by way of court dues. We think there is considerable merit in this suggestion. We plan to investigate executry law and practice in the near future and propose to take up this helpful suggestion then. Meanwhile we make no recommendations for restricting or dispensing with caution.

8.38 A surviving spouse who inherits the deceased's whole estate by virtue of prior rights is not required to find caution. Under our recommendations prior rights will disappear. The surviving spouse will be entitled to the whole estate if the estate is

1. Currie, *Confirmation of Executors*, p229. Certain exceptional debts are deductible.

2. Executors (Scotland) Act 1900, s 6.

3. See *Journal of the Law Society of Scotland*, 1967, p 258 for an instance of a misappropriation of a civil service gratuity.

4. Para 5.33.

5. Para 5.34.

6. Para 5.36.

less than £100,000 or such other sum as may be prescribed, or if the deceased is not survived by issue. We think a surviving spouse should not be required to find caution where he or she is entitled to the whole estate under the proposed new rules on intestacy. We recommend that:

49. A surviving spouse appointed as executor-dative should, as at present, not be required to find caution before confirmation where the deceased died intestate and the spouse is entitled to the whole estate.

(Schedule 1, paragraph 1)

8.39 In commenting on our proposals on caution, the Law Society of Scotland expressed concern over repudiation of claims under bonds by cautioners on grounds of non-disclosure or material error by executors in their form of application for bonds. In *Harrison v Butters*¹ a woman who had been living with the deceased was appointed executor-dative, obtained caution and was confirmed on the basis that she was the deceased's widow. The true widow came to light later and claimed on the bond of caution. It was held that the cautioners were not liable since the bond was void on the ground of essential error. The cautioners thought they were contracting with the widow but they were in fact "contracting" with a cohabiting partner. Avoidance on the ground of non-disclosure means the protection afforded to the true beneficiaries by caution may be worthless. On the other hand to require cautioners to pay under bonds of caution whatever the circumstances would create as many problems as it solves. A universal bond² would avoid this problem completely since the bond would cover all executors-dative without regard to their relationship or absence of relationship to the deceased.

Transfer of lease by executor

8.40 Prior to 1964 the interest of a tenant who died without making a valid bequest of his or her interest under a lease passed to the heir-at-law of the tenant, who was almost invariably³ a single individual selected according to the rules of primogeniture and preference for males. The Succession (Scotland) Act 1964 abolished the heir-at-law and the special rules of heritable succession so that the deceased's interest might, like the rest of the intestate estate, be subject to claims by more than one person. To avoid fragmentation of the deceased tenant's interest, section 16 of the 1964 Act empowers the executor to transfer an interest, which had not been validly bequeathed⁴, to a single member of the deceased's family entitled to share in the intestate estate by virtue of prior or legal rights or succession to the free estate.

8.41 Section 16(2) of the 1964 Act empowers the executor to transfer the deceased's interest as tenant under a lease to a person with an interest in the estate, but there is no express statutory provision preventing an executor from transferring the interest to himself or herself as an individual. In *Inglis v Inglis*⁵ it was held that where one son, with the widow as co-executor-dative, transferred the interest in a farm tenancy to himself, he acted as *auctor in rem suam*. A person in a fiduciary capacity (such as a trustee or executor) is said to be acting as *auctor in rem suam* if he or she transacts with him or herself as an individual. Such a transaction is voidable at the instance of a co-executor or co-trustee or a beneficiary⁶, and where a trustee or executor obtains as an individual a renewal of a lease which formed part of the estate he or she is deemed to hold it on a constructive trust for the beneficiaries.⁷ Accordingly

1. 1969 SLT 183.

2. See para 8.37 above.

3. Where the nearest relatives were females primogeniture did not apply and they succeeded as heirs portioners, each taking a share in the interest. However, it was standard practice for leases to provide that the eldest should succeed without division, see para 6.13 above.

4. An interest in a lease is not validly bequeathed if the deceased tenant cannot bequeath the interest, or the bequest is not accepted by the beneficiary, or the bequest is declared null and void under the various statutory provisions relating to agricultural leases. See for example Agricultural Holdings (Scotland) Act 1949, s 20. Most interests are intestate estate as formal leases invariably prohibit a bequest.

5. 1983 SLT 437.

6. Wilson and Duncan, *Trusts, Trustees and Executors*, pp 361-362.

7. Wilson and Duncan, p 365.

in *Inglis v Inglis* the son held the tenancy of the farm in trust for himself and the other son as beneficiaries of the intestate estate. The court rejected the argument that section 16 provided a new statutory method of transferring leases which did not incorporate the common law rules relating to transactions *in rem suam*, since section 20 of the 1964 Act makes executors-dative

“subject to the same obligations, limitations and restrictions which gratuitous trustees have or are subject to under any enactment or under common law . . .”.

8.42 Preventing an executor from transferring the deceased's interest in a lease to himself or herself as an individual may cause difficulties. Executors, particularly executors-dative, are often close members of the deceased's family and may well have helped run the farm or business tenanted by the deceased. In these circumstances the executor may be the only person who is interested in taking over the tenancy and who is acceptable to the landlord. On the other hand, where a person transacts *in rem suam* there is an inevitable conflict of interest and even though the transaction may have been conducted with scrupulous fairness there is always the suspicion of underhand dealing. In memorandum 71 we proposed¹ that an executor should be entitled to transfer a deceased tenant's interest in a lease to himself or herself provided the interest was independently valued or the value agreed by all interested parties. This would go a long way towards removing the suspicion that the executor, through private knowledge gained in that capacity, acquired the interest at a less than fair price.

8.43 All those who commented agreed that the prohibition against an executor acting *in rem suam* should not apply to a transfer of a lease under section 16 of the 1964 Act. There was some concern that a proper valuation of the deceased's interest did not sufficiently protect the interests of other beneficiaries. One suggestion made to us was that the other beneficiaries should have to agree to the transfer or be entitled to challenge the transfer by way of application to the Scottish Land Court. We are not attracted to this suggestion. Section 16 of the 1964 Act confers a discretion upon the executor in selecting a transferee without interference from other beneficiaries. Provided the interest is transferred at a proper value, we think the executor should have complete discretion even in a transfer to himself or herself. Another suggestion was that all those interested in acquiring the tenancy should have to bid for it, after receiving full information about the tenancy and its value from the executor. We think such a system would be open to abuse by means of artificially low bids, particularly if only the executor was interested in acquiring the lease.

8.44 In our opinion the best way to protect the interests of other beneficiaries is for the value of the deceased's interest in the lease either to be agreed between them and the executor or fixed in some way. Initially we favoured arbitration where the parties were unable to agree the value. Further consultation with agricultural interests and experts have led us to recommend that such disputes should be determined by the Scottish Land Court. It was pointed out to us that the members and staff of the Land Court are already well versed in this area, that the Land Court would be cheaper and quicker² than arbitration, and that their decisions could be reported giving rise to a body of case law useful to settle future disputes. Interests under leases other than agricultural or crofting leases are also transferable under section 16 of the 1964 Act. Such transfers are probably rare because most non-agricultural commercial property is let to firms or companies rather than individuals. Disputes as to the value of the tenant's interest in a non-agricultural lease for the purposes of transfer under section 16 should, we think, be determined by the Lands Tribunal for Scotland for reasons similar to those which lead us to prefer the Land Court for agricultural leases. Although we initially proposed independent valuation only for the case where the executor transferred the tenancy to himself or herself, we now think these provisions should apply to a transfer to any person, since in these cases as well the value of the shares of other beneficiaries in the deceased's estate will be affected by the value at which the tenancy is transferred.

1. Para 7.8.

2. The transfer of a deceased tenant's interest must normally be completed within 1 year from the date of death, s 16(3)(b).

8.45 Where the deceased's interest in a lease is to be transferred under section 16, the executor should initially determine the value at which the interest is proposed to be transferred. The value may be based on an up-to-date independent professional valuation or the date of death value in the inventory may be used. The value should be then intimated to all those whose share of the estate would be financially affected by the value placed on the interest, provided that they can be identified and traced after reasonable enquiries have been made. Because an interest transferred under section 16 is intestate estate, those financially affected are the heirs on intestacy and, in the case of partial intestacy, any person who has claimed legal share. Those financially interested could either agree to accept the executor's value or agree on some other value. Provided all those concerned agree, we do not think it matters what the other value is. In the event of disagreement the value should be determined by the Land Court or the Lands Tribunal for Scotland. The interest should be valued as at the date of the executor's intimation of the initially determined value to the beneficiaries.

8.46 Summing up the proposals made in the preceding paragraphs we recommend that:

50(a) Where an interest of a deceased tenant under a lease is to be transferred under section 16 of the Succession (Scotland) Act 1964 the executor should determine the value of the interest and intimate it to the proposed transferee and those whose share of the estate would be financially affected by the value placed on the interest, provided that they can be identified and traced after reasonable enquiries have been made. In the event of the executor, the proposed transferee, and the others financially interested failing to agree on the executor's value (or any other value) the value should be determined by the Scottish Land Court (where the lease was of an agricultural holding or a croft) or the Lands Tribunal for Scotland (for other cases).

(b) An executor should be entitled to transfer the interest to himself or herself as an individual, provided the above procedure is used.

(Clause 22)

Transfer in satisfaction of claim

8.47 Section 16 of the Succession (Scotland) Act 1964 provides for a transfer of the deceased's interest in a lease to a person entitled to succeed to the deceased's intestate estate or to claim legal or prior rights out of the estate "in or towards satisfaction of that person's entitlement or claim". If the person's entitlement is say £20,000 and the value of the interest in the lease is £10,000, it is clear that the transferee's entitlement is satisfied to this extent. However, where the value of the interest is more, say £25,000, it is not clear whether the transferee is bound to pay £5,000 to the estate or the transfer is in satisfaction of the entitlement or claim without any obligation to pay the excess. In memorandum 71 we proposed¹ that this doubt should be removed by an express provision obliging the transferee to pay the difference between the value of the transferred interest (fixed by agreement or otherwise) and the value of the entitlement or claim. All those who commented agreed that such a provision was desirable. We recommend that:

51. Where an executor transfers the deceased's interest in a lease under section 16 of the Succession (Scotland) Act 1964 to a person and the value of the interest (as determined by the Land Court or the Lands Tribunal for Scotland in default of agreement) exceeds the value of that person's entitlement or claim to a share of the estate, that person should be under an express statutory obligation to pay to the estate a sum being the value of the interest less the value of the entitlement or claim.

(Clause 22)

1. Para 7.9.

Part IX Miscellaneous

Adopted children

9.1 The policy of the present law is to place an adopted child in the same position as a biological child of the adopter or adopters for all purposes relating to succession or the disposal of property by virtue of an *inter vivos* deed.¹ This is achieved by a general provision² and by a particular provision on the construction of deeds which is in the following terms.³

“(2) In any deed whereby property is conveyed or under which a succession arises, being a deed executed after the making of an adoption order, unless the contrary intention appears, any reference (whether express or implied)—

- (a) to the child or children of the adopter shall be construed as, or as including, a reference to the adopted person;
- (b) to the child or children of the adopted person’s natural parents or either of them shall be construed as not being, or as not including, a reference to the adopted person; and
- (c) to a person related to the adopted person in any particular degree shall be construed as a reference to the person who would be related to him in that degree if he were the child of the adopter and were not the child of any other person:

Provided that for the purposes of this subsection a deed containing a provision taking effect on the death of any person shall be deemed to have been executed on the date of death of that person.”

Some doubt has been expressed as to whether a reference in a deed to the “issue” of X includes X’s adopted child or X’s child’s adopted child. In memorandum 71 we suggested that there should be no room for any doubt on these points and that a reference to the issue of X should, as a matter of policy, include X’s adopted child and X’s child’s adopted child unless the contrary intention appeared.⁴ We also pointed out that the reference in paragraph (c) of the provision quoted above to a person “related to the adopted person in any particular degree” might be too narrow. A reference to, say, “ascendants” or “collaterals” of an adopter would be to people related in a particular way, not in a particular degree. We therefore suggested that, to avoid any possibility of doubt, the words “or issue” should be inserted after the word “children” in paragraphs (a) and (b) of section 23(2) of the Succession (Scotland) Act 1964 and that the words “or way” should be added after the word “degree” in both places where it appeared in paragraph (c). These suggestions were agreed by all who commented on them. We therefore recommend that:

52. To avoid any possibility of a doubt as to the extent to which an adopted child is regarded as included in his adoptive family for the purposes of section 23(2) of the Succession (Scotland) Act 1964,

- (a) the words “or issue” should be inserted after the word “children” in paragraphs (a) and (b) of that subsection, and**

1. Succession (Scotland) Act 1964, s23(1). This does not apply where the adopter or adopters died before 10 September 1964, Law Reform (Miscellaneous Provisions) Act 1966, s5. In such a case the child retains rights of succession to the natural parent.

2. 1964 Act, s23(1).

3. 1964 Act, s23(2). Nothing turns on the word “deed” here because, by s36(1) it is defined so as to include any writing.

4. Para 4.3.

(b) the words “or way” should be added after the word “degree” in both places where it appears in paragraph (c) of that subsection.

(Schedule 1, paragraph 20)

9.2 The draft Bill attached to this report groups together the provisions on adoption presently contained in the Succession (Scotland) Act 1964 and the Law Reform (Miscellaneous Provisions)(Scotland) Act 1966 and decants them to the part of the Adoption (Scotland) Act 1978 dealing with the legal position of adopted children, which is where the provisions more naturally belong. This involves some minor and consequential changes of wording which do not affect the substance of the provisions. In the course of doing this decanting, however, we came to the conclusion that one provision should be discarded altogether on policy grounds. It is the provision in section 24(1A) of the Succession (Scotland) Act 1964¹ to the effect that, for purposes of seniority in relation to succession and the disposal of property under an *inter vivos* deed, an adopted person ranks as if born on the date of his adoption.² This means that if a testator leaves certain property to his elder child and certain other property to his younger child and if he is survived by an adopted child aged 40 (adopted at the age of 5) and a natural child aged 37, the property left to the elder child will go to the 37 year old and the property left to the younger child will go to the 40 year old. The first 5 years of the adopted child's life are, as it were, deducted from his age so that he is notionally only 35. This seems to us to border on the absurd. It is contrary to the principle of treating adopted children as if they were natural children of the adopter³ and it is unlikely to give effect to the wishes of the testator. The results of section 24(1A) would be even more bizarre if a couple were adopting two sisters aged 5 and 3 and if, for some procedural reason, the date of the 5 year old's adoption was a day later than the date of the 3 year old's. The younger sister would then become the elder, and the elder the younger. We think that this provision should be quietly dropped. We recommend that:

53(a) The statutory provisions on the effect of adoption on succession and the disposal of property under inter vivos deeds should be grouped together and placed in the appropriate part of the Adoption (Scotland) Act 1978.

(b) Section 24(1A) of the Succession (Scotland) Act 1964 (relative seniority of adopted child to depend on date of adoption rather than actual age) should, however, be repealed and not re-enacted.

(Schedule 1, paragraphs 19 and 20)

Mournings

9.3 In memorandum 71 we suggested that the rule that the widow and family of a deceased person were entitled to an allowance out of his estate for mournings suitable to his social position should cease to have effect.⁴ We suspected that this rule was nowadays little used, if at all. It appeared to be anachronistic, given the decline in the use of special mourning clothes, and to be discriminatory in that it applied only to widows, and not to widowers. All of those who commented on this point agreed with our suggestion. We therefore recommend that:

54. The rule of law entitling the family of a deceased person to an allowance from his estate for mournings should be abolished.

(Clause 25)

1. Added by the Children Act 1975, Sch 2 para 5.

2. The provision is as follows, omitting some qualifications not relevant here.

“(1A) Where, in relation to any purpose specified in section 23(1) of this Act, any right is conferred or any obligation is imposed, whether by operation of law or under any deed . . . by reference to the relative seniority of the members of a class of persons, then . . .

(a) any member of that class who is an adopted person shall rank as if he had been born on the date of his adoption, and

(b) if two or more members of the class are adopted persons whose dates of adoption are the same, they shall rank as between themselves in accordance with their respective times of birth.”

3. See the Succession (Scotland) Act 1964 s23(1) and the European Convention on the Adoption of Children (1967) art 10(5) (Cmd 3673).

4. Para 8.1.

Aliment jure representationis

9.4 The idea of aliment *jure representationis* is that a person entitled to aliment from another person has a claim for aliment against someone succeeding to that other person's estate. The origin of the idea lay in the old law of succession under which the eldest son succeeded to the heritable estate. If a person died leaving substantial lands but very little moveable property the younger children might be unprovided for. In such circumstances the law made the heir liable for the aliment of his brothers and sisters. He was regarded as representing his father in the alimentary obligation and was therefore said to be liable *ex jure representationis*. The rule was later extended to other cases and the law on the subject became complicated and unclear.¹

9.5 The abolition of the distinction between heritable and moveable property for purposes of succession and the extension of the legal shares of surviving spouse and issue to the whole of a deceased's estate make it possible to abolish this ancient, and now little used, rule of law. As a matter of practice it is undesirable to hold up the administration of an estate to enable executors to pay aliment out of it for, perhaps, many years. As a matter of policy, it seems undesirable to saddle a person succeeding to property under a deceased person's will, or on intestacy, with a continuing obligation to aliment the deceased person's widow or children. The appropriate way of protecting the surviving spouse and children is, we believe, by means of legal shares as recommended earlier. Almost all consultees who commented on the question agreed with this approach. We therefore recommend that:

55. Aliment ex jure representationis should be abolished. Accordingly it should no longer be possible for a person entitled to aliment from another person to claim, after that person's death, aliment from that person's executor or from anyone enriched by the succession to that person's estate.

(Clause 27)

Temporary aliment out of estate of deceased person

9.6 Under the existing law, the widow and children of a deceased man have a right to temporary aliment out of his estate.² This is quite distinct from the continuing aliment *ex jure representationis* considered above. It is intended merely to provide temporary support in the period immediately following the death. The right is not to a mere payment to account of sums due from the estate but to a payment which is deducted before the estate is divided.³ The prevailing view is that temporary aliment is not a true debt of the estate and that it cannot be paid if the estate is clearly insolvent.⁴ If, however, the estate is not clearly insolvent the executors are within their rights in paying temporary aliment to the widow or children before confirmation or even within the six months after the death and will not be liable to reimburse the estate should it ultimately prove to be insolvent.⁵ Surprisingly, it has been held that a widow is entitled to temporary aliment out of her husband's estate even where she was in desertion and hence not entitled to aliment from him during his life.⁶

9.7 When the main provision for the widow of a wealthy man took the form of a liferent of a third of his heritable property (the widow's terce) it was natural to say that her right to temporary aliment out of the estate continued until the first term of Whitsunday or Martinmas after her husband's death. At that term she would normally begin to draw her third share of the rents from the land. Nowadays this is no longer an appropriate way of determining the duration of the right to temporary

1. See generally our memorandum on *Aliment and Financial Provision* (Memo No 22, 1976) paras 4.3 to 4.16.

2. *Barlass v Barlass's Trs* 1916 SC 741.

3. *Breadalbane's Trs v Breadalbane* (1843) 15 Sc Jur 389; *Baroness de Blonay v Oswald's Repts* (1863) 1 M 1147 at p1153; *McIntyre v McIntyre's Trs* (1865) 3 M 1074.

4. *Lindsay's Creditors v His Relict* (1714) Mor 11847; *Buchanan v Ferrier* (1822) 1 S 323. Contrary views were however expressed in *Barlass v Barlass's Trs* 1916 SC 741 at pp748 and 749.

5. *Barlass v Barlass's Trs*, above.

6. *MacCallum v Maclean* 1923 SLT (Sh Ct) 117.

aliment and the modern approach seems to be to allow aliment for the six months following the death.¹

9.8 There are arguments for and against the right to temporary aliment out of the deceased's estate. In favour of the right it can be argued

- (a) that it is reasonable and humane to provide for the aliment of the deceased's spouse and children in the period between the death and the time when anything due to them from the estate can safely be paid, and
- (b) that the right is particularly valuable where it is uncertain whether the estate will be insolvent and where it turns out eventually to be insolvent.

Against the right it can be argued

- (a) that it is unnecessary in the average case either because the spouse and children will have other funds at their disposal or because the estate is clearly solvent and payments to account can safely be made out of the estate,
- (b) that it is contrary to principle to prefer alimentary creditors to general creditors because those entitled to aliment must follow the fortunes of the person liable to pay it, and
- (c) that the right has fallen largely into disuse and could be swept away, with resulting simplification of the law, without producing ill effects in practice.

9.9 In memorandum 71 we reached no conclusion on this point but invited views on the following questions.²

- (a) Should the right to temporary aliment out of the deceased's estate be abolished or retained?
- (b) If the right is retained should it
 - (i) be available to, and only to, a person entitled to aliment from the deceased at the date of his or her death
 - (ii) be available for the period of six months after the date of death
 - (iii) have preference over the claims of creditors on the estate, at least if the estate is not manifestly insolvent at the time of the payment in question?

9.10 There was a division of opinion on consultation. Some bodies and individuals thought that the right was little used in practice and could safely and usefully be abolished. Others thought that the right was still occasionally useful and should be retained. The Law Society of Scotland initially favoured retention of the right but later changed its view and came out strongly against anything other than payments to account. We consider that, on balance, the arguments against retaining a special right to temporary aliment out of the estate of a deceased person are stronger than the arguments in favour. In practice, we understand, payments to account of the recipient's share in the estate are found to meet the needs of the situation and we are impressed by the fact that, on reconsidering this issue, the Law Society of Scotland expressed strong opposition on principle to anything other than payments to account. Abolition of this little known, and little used, right would simplify the law without causing hardship or inconvenience. We therefore recommend that:

56. The right of certain relatives to claim temporary aliment out of a deceased's estate should be abolished.

(Clause 26)

Deathbed

9.11 At one time the law of Scotland enabled certain transactions effected by a deceased person on his deathbed to be challenged and reduced.³ The main purpose

1. *Barlass v Barlass's Trs; MacCallum v Maclean*, above.

2. Para 8.6.

3. Erskine, III, 7, 46; McLaren, *Wills and Succession*, pp170-193.

of the rule was to prevent heritable property from being diverted on deathbed from the deceased's heirs, but it was also applied to prevent the defeat of legal rights.¹ A deed was not regarded as being on deathbed if, since its date, the granter had been "at kirk or market unsupported" but "no other proof of convalescence was receivable".² An Act of 1871, on the preamble that it was "expedient to abolish all challenges and reductions in Scotland *ex capite lecti*" (ie on the ground of deathbed) provided that "no deed, instrument or writing, made by a person who shall die after the passing of this Act shall be liable to challenge or reduction *ex capite lecti*".³ The intention of the Act was clear but there is some doubt, at least in theory, as to whether it achieved its intention. Its terms are confined to written transactions and it has been argued that other transactions are not affected.⁴ In practice, so far as we are aware, the law of deathbed has been regarded as long since abolished. Although the matter is by no means of pressing importance we think that the opportunity of a general statute on succession law might be used to resolve this doubt and to make it clear that the whole law of deathbed is abolished. We therefore recommend that:

57. It should be made clear that the abolition of challenges and reductions on the ground of deathbed extends to all transactions, whether or not effected in writing.

(Clause 31)

Donations mortis causa

9.12 A donation *mortis causa* was defined in the leading case of *Morris v Riddick*⁵ as

"... a conveyance of an immoveable or incorporeal right, or a transference of moveables or money by delivery, so that the property is immediately transferred to the grantee, upon the condition that he shall hold for the granter so long as he lives, subject to his power of revocation, and, failing such revocation, then for the grantee on the death of the granter. It is involved of course in this definition, that if the grantee predecease the granter the property reverts to the granter, and the qualified right of property which was vested in the grantee is extinguished by his predecease."

Morris v Riddick also established that a donation *mortis causa* does not need to be in writing or to be evidenced by writing. It does not defeat legal rights. It is liable for the donor's debts if there is a deficiency of funds in his estate for their payment. It cannot, however, be recalled by the executor merely because there is a deficiency of funds for legacies: it is preferable to legacies. Although the reference in the above quotation to the donee holding for the donor might seem to imply that the donee is merely a trustee, this idea has not been taken further and in subsequent cases it was assumed that the donee becomes the immediate beneficial owner of the property, subject to the double resolutive condition that the property is returnable (a) if the donor revokes the gift in his lifetime and (b) if the donee predeceases the donor.⁶ It also became established that a donation *mortis causa* must be made in contemplation of death, though not necessarily under apprehension of imminent death.⁷ Accordingly, to establish a donation *mortis causa* in Scots law it is settled that

"in addition to evidence that the gift is made in contemplation of death there must be evidence of a *de praesenti* transfer to the donee of a right or of an asset subject to a double resolutive condition, namely, that the subject reverts to the donor (a) if the donee predeceases the donor, and (b) if the donor revokes the gift."⁸

1. Erskine, III, 9, 5; Fraser, *Husband and Wife*, Vol 2, pp1006-1008.

2. Erskine, III, 7, 47.

3. "An Act to abolish Reductions *ex capite lecti* in Scotland." This Act was itself repealed by the Statute Law Revision Act 1883 but that did not, of course, revive the old law.

4. Fraser, *op cit*, p1008. The question was left open in *Hay v Coutts' Trs* (1890) 18 R 244. In the *Lauderdale Peerage Case* (1885) App Cas 692 the House of Lords assumed that the whole law of deathbed was abolished.

5. (1867) 5 M 1036 at 1041.

6. See *Macpherson's Ex v Mackay* 1932 SC 505.

7. *Blyth v Curle* (1885) 12 R 674; *Aiken's Ex v Aiken* 1937 SC 678.

8. *Graham's Trs v Gillies* 1956 SC 437 at 448.

Many of the modern cases on donation *mortis causa* have concerned deposit receipts and the issue in them has often been whether the gift was sufficiently constituted by delivery or by an equivalent to delivery.¹

9.13 It follows from the nature of a donation *mortis causa* in Scots law that it does not form part of the deceased's estate at death. The property has been given away, subject to resolutive conditions. We have considered whether a donation *mortis causa* ought to be notionally added back to the estate for the purposes of the legal share of the spouse or issue. We have decided not to recommend this. It is difficult to justify treating a donation *mortis causa* differently in this respect from any other revocable donation, or indeed from an irrevocable donation made shortly before death. The converse question is whether a person claiming legal share should be required to forfeit a donation *mortis causa* received from the deceased. We think that the same reasoning ought to apply and that the donation should be treated like any other revocable donation which has not been revoked.

9.14 Under our recommendations in this report the other situation in which a person forfeits rights of succession which he or she would otherwise have in a deceased's estate is where he or she has wrongfully killed the deceased. The question for consideration is whether a donation *mortis causa* received from the deceased ought to be forfeited in the same way as a legacy. Although it could be argued that a donation *mortis causa* ought to be treated like any other donation for this purpose we have concluded that in this case the gift ought to be forfeited. By killing the donor the donee has cut short the donor's power to revoke the gift and, on general grounds of public policy, ought not to profit from that. Cases involving donees of donations *mortis causa* who have unlawfully killed the donors will, we imagine, be rare or non-existent. So the problem is unlikely to be one of great practical importance.

9.15 The only other context in which donations *mortis causa* have to be considered is the 5 day survival rule.² The question here is whether a donee under a donation *mortis causa* who dies within 5 days after the donor should be treated, for purposes of the donation, as having failed to survive the deceased. Although arguments could be made for the other solution, we think that the donee should be regarded as having failed to survive the donor in this situation. Although cases are likely to be extremely rare it could, we think, be confusing to have different rules on survivorship for the purposes of legacies and donations *mortis causa*.

9.16 We recommend that:

58(a) Donations *mortis causa* should not be deemed to be part of the donor's estate for the purpose of the legal share of spouse or issue. Accordingly legal share should not be claimable out of them and they should not be forfeited by a person making a claim.

(b) Donations *mortis causa* should be returnable not only (as under the present law) if the donee fails to survive the donor but also if

(i) the donee incurs forfeiture as a result of having unlawfully killed the donor, or

(ii) the donee fails to survive the donor by five days.

(Clauses 19(1), 28(8) and 36(1))

Vesting of fee on forfeiture or renunciation of liferent

9.17 Under the present law the early termination of a liferent (for example, by forfeiture or renunciation) does not normally accelerate vesting of the fee.³ The result

1. The cases are reviewed in *Graham's Trs v Gillies*.

2. See para 5.4 above.

3. In the case of a simple bequest "to A in liferent and B in fee" there would normally be vesting of the fee in B on the death of the testator in any event. See *Carleton v Thomson* (1867) 5M (HL) 151. However, vesting will usually be postponed if there is a destination over or survivorship clause—eg if the bequest is "to A in liferent and B whom failing C in fee". See *Young v Robertson* (1862) 4 Macq 314. In this case a forfeiture or renunciation of the liferent does not normally accelerate vesting in the fee. See *Muirhead v Muirhead* (1890) 17R (HL) 45.

is that there can be difficulties in knowing what to do with the income which continues to arise during the life of the liferenter but which cannot be paid over to the liferenter. A liferent in this situation has been described as a "shadow" liferent.¹ We have already recommended that where legal share is claimed the claimant should forfeit all other rights of succession in the deceased's estate and should be treated as having predeceased the deceased.² One result of this is intended to be that if estate had been left to the claimant in liferent and someone else in fee in such a way that vesting in the fee would normally take place on the death of the liferenter, vesting in the fee would be accelerated. That seems to us to be a far more natural and practicable result than leaving the fee unvested and coping somehow with the problem of a "shadow" liferent.³ As it may not be clear that this result would follow from the general provisions in the draft Bill on the effect of claiming legal share, we think that an express provision to this effect should be included. The provision should also cover the case where a divorced spouse is deemed to have failed to survive the deceased for the purposes of a testamentary liferent in his or her favour⁴ and the case where forfeiture takes place because the liferenter has unlawfully killed the testator.⁵ It would be anomalous to have accelerated vesting in the case of a forfeiture of a liferent but no accelerated vesting in the case of a renunciation of a liferent or early termination for any other reason. We therefore recommend that:

59. Where property has been left to one person in liferent and another person in fee, and the liferent is forfeited or renounced by the liferenter, or otherwise terminates before the liferenter's death, then the fee should, unless the document creating the liferent expressly provides otherwise, vest in the fiar at the time when it would have vested if the liferenter had died on the date of the forfeiture, renunciation or termination.

(Clause 18)

The effect of this recommendation would be to reverse the rule of the present law that the early termination of a liferent by forfeiture or renunciation does not accelerate vesting in the fee unless the document in question so provides and to make it clear that only express provision in the relevant document would postpone vesting beyond forfeiture or renunciation and create a "shadow" liferent. It is hard to believe that any sane testator would wish to create a situation in which there was a liferent but no liferenter. The net result should be the avoidance of a good deal of difficulty, expense and litigation.⁶

Inheritance tax

9.18 Under the recommendations in this report the legal share of spouse or issue would not vest on the death of the deceased. All that would happen on the deceased's death is that the spouse and issue would acquire a right to claim legal share, at the price of forfeiting all other succession rights. Moreover issue could not claim legal share out of the first £100,000 of estate passing to the surviving spouse. In most cases there would be no claim for legal share and the estate would be distributed under the rules of intestate succession or in accordance with the deceased's will. This change from legal rights which vest on death in all cases to legal shares which are payable only if claimed necessitates certain minor consequential changes in the inheritance tax legislation.

9.19 Inheritance tax is charged on a transfer of value which is not an exempt transfer.⁷ Under the present law of Scotland a renunciation of legal rights (which have

1. See Gretton, "Vesting, Equitable Compensation and the Mysteries of the Shadow Liferent" 1988 SLT (News) 149.

2. Para 3.46.

3. See clause 18 of the draft Bill.

4. See clause 14 of the draft Bill.

5. See clause 19 of the draft Bill.

6. This issue has given rise to a surprising amount of litigation. For the older cases see Henderson, *Vesting* pp298-310. See also *A v B's Trs* 1941 SLT 193; *Gray's Trs v Neilson* 1946 SN 81; *Middleton's Trs v Middleton* 1955 SC 51; *Chrystal's Trs v Haldane* 1960 SC 127; *Hurll's Trs v Hurll* 1964 SC 12; *Whitelaw's Trs v Whitelaw's Trs* 1981 SLT 94.

7. Inheritance Tax Act 1984, s1.

already vested on death) would clearly be a transfer of value in the absence of any special provision to the contrary and could accordingly be liable to inheritance tax if the renouncer died within 7 years. Section 17(d) of the Inheritance Tax Act provides, however, that “the renunciation of a claim to legitim” before the person entitled to it attains the age of 18 or within two years of his attaining that age or such longer period as the Board of Inland Revenue may permit is not a transfer of value.¹ As legitim vested under the present law may be renounced in the future even after a new law on legal shares has come into force this provision should clearly remain in existence. We considered in memorandum 71 the possibility of extending it to cover other cases of incapacity, such as a mentally ill spouse who renounced legal rights on recovering capacity many years after the other spouse’s death. Given, however, that this type of situation would be extremely rare and that section 17(d) will survive only as a transitional measure to deal with legal rights arising on deaths before the new legislation comes into force we have decided not to pursue this idea. We have considered whether it would be necessary to have an equivalent provision to section 17(d) to make it clear that a renunciation of the right to claim, or a failure to claim, legal share would not be a transfer of value. A transfer of value is “a disposition made by a person (the transferor) as a result of which the value of his estate immediately after the disposition is less than it would be but for the disposition”.² Moreover, where the value of a person’s estate is diminished and that of another person’s estate is increased by the first person’s omission to exercise a right, the first person is treated as having made a disposition at the time (or latest time) when he could have exercised the right, unless it is shown that the omission was not deliberate.³ The need for a special provision is diminished by the fact that the period for claiming legal share under our recommendations would be limited to two years after the deceased’s death. Within this period legal rights in the deceased’s estate could, in any event, be disclaimed by an instrument in writing (commonly called a deed of family arrangement) without giving rise to a potential charge to inheritance tax and the same rule should clearly apply to legal shares.⁴ However, there might not be an “instrument in writing”. A person may simply fail to claim legal share. He or she may be content to let the deceased’s will take effect. The position of a person who fails to claim legal share would be the same in this respect as that of a person who failed to claim a provision under the Inheritance (Provision for Family and Dependents) Act 1975 on the death of a person domiciled in England and Wales. Notwithstanding the much more limited nature of the problem under the new scheme we think that there is still a need for a provision. We therefore recommend that:

60. A renunciation of the right to claim, or a failure to claim, legal share should not be a transfer of value for the purposes of the Inheritance Tax Act 1984.
(Schedule 1, paragraph 24)

9.20 Chapter III of the Inheritance Tax Act 1984 deals with the question of the allocation of certain exemptions.⁵ Section 42 (described as “Supplementary” in the side-note) is the last section in Chapter III and provides in subsection (4) that

“Where on the death of a person legal rights under the law of Scotland are claimed by a person entitled to claim them, they shall be treated for the purposes of this Chapter as a specific gift which bears its own tax; and in determining the value of such legal rights, any tax payable on the estate of the deceased shall be left out of account.”

It will be noted that it is only for the purposes of Chapter III that legal rights are treated as a specific gift which bears its own tax. If Chapter III does not come into operation the general rule is that inheritance tax is treated as part of the general testamentary and administration expenses of the estate.⁶ Section 42(4) is framed in

1. S17(d) as read with s147(6).

2. Inheritance Tax Act 1984, s3(1).

3. Inheritance Tax Act 1984, s3(3).

4. Inheritance Tax Act 1984, s17(a) and s142(1).

5. The exemptions in question are those for—transfer to spouse (s18), gift to charity (s23), gift to political party (s24), gift for national purpose (s25), gift for public benefit (s26), maintenance funds for historic buildings etc (s27), conditionally exempt transfer with respect to certain property (eg buildings of outstanding historic or architectural interest) designated by the Treasury (s30).

6. Inheritance Tax Act 1984, s211(1).

a way which, curiously, seems to anticipate a change to a system where legal rights (or legal share) have to be claimed. It requires only minor amendment, therefore, to make it refer to legal share. Because legal rights under the old law may continue to be claimed for some time after the commencement of the new legislation the amendment should add a reference to legal share but should not remove the reference to legal rights. We recommend that:

- 61. Section 42 of the Inheritance Tax Act (treatment of legal rights for purposes of allocation of exemptions) should be amended to include a reference to legal share under the new legislation.**

(Schedule 1, paragraph 25)

9.21 Section 147 of the Inheritance Tax Act deals with the situation where the deceased is survived by a spouse and a person under the age of 18 entitled to claim legitim, and where the claim for legitim would result in a diminution of the amount inherited by the spouse, and hence a diminution in the estate exempt from inheritance tax under the "transfer to spouse" exemption. Section 147 in effect enables the executor to elect to have tax charged either on the basis that legitim has been taken or on the basis that it has been renounced. If the person entitled to legitim subsequently claims or renounces, not later than two years after attaining the age of 18 (or such later date as the Board of Inland Revenue may allow) and if the decision is not in accord with the executor's election then inheritance tax is recalculated accordingly. If a person has not renounced legitim by the time limit mentioned he is treated as having claimed it. The provisions in section 147 are only necessary because of the prolonged time within which an election to take or renounce legal rights can be made. It would not be necessary under the recommendations in this report. It should not be repealed entirely because there could still be claims for, or renunciations of, legitim arising out of deaths occurring before the new legislation comes into force. In relation to the situation under the new legislation all that would be necessary would be a provision to the effect that where legal share is claimed within the permitted period¹ after the deceased's death the Inheritance Tax Act should apply as if the amount taken by way of legal share had been bequeathed by the deceased to the claimant.² This, of course, implies that the shares of the estate taken by other people would be adjusted accordingly. We recommend that:

- 62. A provision should be added to the Inheritance Tax Act 1984 to the effect that where legal share is claimed within the permitted period after the deceased's death the Act should apply as if the amount taken by way of legal share had been bequeathed by the deceased to the claimant.**

(Schedule 1, paragraph 26)

9.22 Several problems relating to legitim and inheritance tax under the present law were brought to our attention by consultees. These were caused by the restriction of legitim to moveables and by the law on collation of advances. They would not arise under the new rules on legal share recommended in this report.

Definition of "estate" and related terms

9.23 The rules of succession, including the rules on legal share, are concerned with the devolution of the property belonging to the deceased at the time of his death. As a matter of principle, therefore, the definition of estate for the purposes of these rules, once different treatment of heritable and moveable property has been eliminated, ought to be simply the property belonging to the deceased at the time of his death. A definition in these terms has the advantage of resolving the question, left uncertain under the existing law on legal rights, whether legal shares can be claimed out of estate falling into the executry after the deceased's death.³ As a matter

1. See clause 6 of the draft Bill. The period is normally two years.

2. Cf s146(1) of the Inheritance Tax Act 1984 which deals with the effect of a successful claim under the (English) Inheritance (Provision for Family and Dependents) Act 1975.

3. Contrast *Wilson's Trs v Glasgow Royal Infirmary* 1917 SC 527; *Lindsay's Trs v Lindsay* 1931 SC 586 with *Moon's Trs v Moon* (1899) 2 F 201; *Mackay's Trs v Mackay* 1909 SC 139 and *McGregor's Trs v Kimbell* 1911 SC 1196.

of principle they ought not to. If the deceased had a right to the property then that right formed part of his estate and would be liable to legal share, with interest. If the after-acquired property is a gift to the executry then the destination of the property is a matter of construction of the terms of the gift and has nothing to do with succession to the deceased. The draft Bill accordingly defines "estate" for its purposes as the whole estate of whatever kind belonging to the deceased at the time of his death.¹ This is subject to the ordinary rules of private international law whereby (at present) the Scottish law on succession does not apply to foreign immovables.² The draft Bill does not include, in the definition of "estate", property over which the deceased had a power of appointment. Such property was not the deceased's property and it would be wrong to subject it to the rules of succession and legal share as if it was. Property belonging to the deceased and subject to a special destination is, however, clearly part of his estate and is accordingly not excluded from the definition of "estate". The fact that it is destined to someone else is no more relevant for this purpose than would be the fact that it was the subject of a bequest to someone else.³

9.24 The definition of "estate" just mentioned relates to gross estate. From this, certain liabilities have to be deducted in order to arrive at the net estate to which the rules on succession and legal share actually apply. There is no difficulty regarding the debts for which the deceased was liable at the date of his death. They clearly have to be deducted. It has been traditional practice to regard funeral expenses as deductible in the same way, although strictly speaking the liability for them arises after the deceased's death. The draft Bill reflects the traditional view on this point.⁴ There is much more difficulty about inheritance tax. Should it be treated as a debt notionally due as at the date of the deceased's death? The problem is that the amount of inheritance tax may depend on the amount of the net estate available for certain beneficiaries. For example, the amount of inheritance tax may depend on how much the surviving spouse receives.⁵ Clearly, it is impossible to have a rule whereby the amount of the net estate depends on the amount of the inheritance tax which in turn depends on the amount of the net estate. It is, therefore, necessary to leave inheritance tax out of account in determining the net estate which is subject to the provisions of the Bill.⁶ This does not, of course, mean that the estate, once the shares of those various beneficiaries have been ascertained, is not liable to inheritance tax. It is, and the draft Bill makes this clear.⁷

9.25 So far as the expenses of realising and administering the estate are concerned, the system of intestate succession and legal share recommended in this report makes it necessary to decide whether these should be deducted before or after the entitlements of heirs and legal share claimants are determined.

Example 1

A man dies intestate leaving an estate, after debts and funeral expenses, of £102,000. He is survived by a wife and son. The expenses of realising and administering the estate come to £3,000. There is no inheritance tax and, let us suppose for the purposes of the example, no income arising during the administration.

(a) If the entitlements of the widow and son are decided on the basis of the net estate without deduction of the expenses of administration then the widow receives the first £100,000 plus half the excess and the son receives the other half of the excess.

| | |
|-------|----------|
| Widow | £101,000 |
| Son | 1,000 |

The expenses of realising and administering the estate will be deducted rateably from these shares. The son's share is approximately 1% of the widow's. So approximately 1% of the expenses (about £30) will be deducted from his share.

-
1. Clause 36(1).
 2. Clauses 32(3) and 36(1).
 3. For further discussion of property subject to a special destination and the treatment of such property for the purposes of the Succession (Scotland) Act 1964 see Part VI.
 4. Clause 36(1).
 5. Inheritance Tax Act 1984, s18.
 6. Clause 36(1)—definition of "net estate".
 7. Clause 36(5).

(b) If the entitlements of the widow and son are decided on the basis of the net estate after deduction of the expenses of administration then, as the net estate on this basis is under £100,000 the widow will take it all.

Example 2

A son who has been left a legacy wants to know whether to claim legal share. If legal share is calculated on the basis of the estate before deduction of the expenses of realisation and administration, and if there is adequate residue in the estate to meet all these expenses likely to be incurred, he knows enough to make his election as soon as the amount of the estate and the amount of debts and funeral expenses are ascertained. If legal share is calculated on the basis of the estate after deduction of the expenses of realisation and administration, he will not know the amount of legal share claimable until the administration of the estate is completed.

It seems to us that the better solution is to strike the intestate shares and the legal shares on the basis of the net estate before deduction of the expenses of realisation and administration. These arise after the death, possibly a considerable time after the death, and as a matter of principle they ought not to affect the way in which the deceased's estate falls to be divided. From a practical point of view it is also clearly useful to know as soon as possible after the death how much can be claimed by way of legal shares. Adopting this solution does not, of course, mean that an executor is not entitled to the expenses of administration out of the estate. He is, and nothing in the draft Bill takes away this right. It is, however, necessary to specify how amounts payable by way of legal share are to be treated for the purpose of deciding which parts of the estate the expenses come out of. At present legal rights are not treated as legacies for this purpose but are treated in a special way, being liable for a share of the expenses of obtaining title to and realising the estate but not for general expenses of administration.¹ This appears to be based on the special character of legal rights as debts in competition with heirs. We can see no reason for continuing this special treatment and suggest that an amount payable by way of legal share should simply, for the purposes of the expenses of realising and administering the estate, be treated as if it had been a legacy of the same amount. We therefore recommend that:

- 63(a) For the purposes of the new rules on intestate succession and legal share the "net estate" forming the basis of division should be the estate belonging to the deceased at the date of his death less**
- (i) the debts for which his estate is liable as at the date of his death; and**
 - (ii) any funeral expenses.**
- (b) Inheritance tax and expenses of administration should not be deducted before the division is made but this should not carry any implication that the estate is not liable for inheritance tax and expenses of administration or that the amounts due to beneficiaries in accordance with the rules of division applying to the net estate will not ultimately have to bear a share of that tax or those expenses.**
- (c) For the purposes of allocating expenses of administration to different parts of the estate any amount payable by way of legal share should be treated as if it had been a legacy of the same amount.**

(Clauses 10 and 36)

9.26 The definition of "net intestate estate" in the draft Bill is self-explanatory. It does not include property which is disposed of under a special destination. In this respect, as in various other respects, a special destination is regarded as the equivalent of a legacy.

Valuation of the estate

9.27 Normally the estate of the deceased is valued for succession purposes as at the date of death. However, an exception to this rule is recognised where items which

1. See *Henderson v. Henderson's Trs* 1916 2 SLT 292; *Russel v Attorney General* 1917 SC 28.

are not capable of accurate valuation (such as furniture or a business) have been realised in the ordinary course of administration and without undue delay after the death. In such cases the realised value will be substituted for the date of death value.¹ We think that it would be useful to have this rule contained in the new statutory provisions and recommend that:

64. The rule that, where items of a deceased's estate which are not capable of accurate valuation at the date of death are realised in the ordinary course of administration without undue delay after his death, the realised value is substituted for the estimated value as at the date of death should be enacted in statutory form.

(Clause 24)

Transitional provisions

9.28 In general the new rules on succession recommended in this report should apply only in relation to deaths occurring after the commencement of implementing legislation. There could be cases where it was uncertain whether a person had died before or after the commencement of the new law. It would be useful in such a case if the person were deemed to have died after commencement. We recommend that there should be a rule to this effect.²

9.29 Where a person dies after the commencement of the new legislation and leaves an imperfectly executed will it should be possible to have that will validated under the provisions in clause 12 of the draft Bill attached to this report even if the will was made before the date of commencement. The same applies to an imperfectly authenticated alteration. Clause 12 should therefore apply to writings made before or after the date of commencement. The same applies to clause 13, which deals with the rectification of wills which fail to give effect to the testator's instructions. These results are achieved in the draft Bill by simply not providing any exception for pre-commencement writings for these purposes. Accordingly the rules in the draft Bill apply to them.

9.30 Our recommendations on the question whether a bequest to a descendant of the testator should go to the issue of that descendant if he predeceases the testator leaving issue, and our recommendations on special destinations would affect the construction of documents. It would be wrong to alter the meaning of documents drawn up under the existing law even if the death in question was after commencement. The draft Bill therefore includes special exceptions for these cases.³ This does not apply, however, to those recommendations on special destinations which are simply designed to make it clear that a deceased's property does not cease to be available for the payment of his debts merely because it is subject to a special destination. They should apply whatever the date of the document containing the destination.

9.31 Our recommendations on transitional provisions are therefore as follows.

- 65(a) In general the new rules of succession law recommended in this report should apply only in relation to deaths occurring after the commencement of implementing legislation ("commencement").**
- (b) Where it is uncertain whether a person died before or after commencement he or she should be deemed to have died after commencement.**
- (c) Where a person dies after commencement, leaving an imperfectly executed will, or alteration to a will, it should be possible to have the will or alteration validated under clause 12 of the draft Bill even if it was made before commencement.**

1. See *Milne v Milne's Trs* 1931 SLT 336; *Alexander v Alexander's Trs* 1954 SC 436.

2. Para 9.31 below.

3. Clause 34(3) and (4)

- (d) **Where a person dies after commencement leaving a will which fails to carry out his instructions it should be possible to rectify the will under clause 13 of the draft Bill even if it was made before commencement.**
- (e) **The recommended new rules on what happens to a bequest to a descendant if he or she predeceases the testator leaving issue, and the recommended new rules on special destinations should not affect documents executed before commencement. This should not apply, however, to the rules designed simply to make it clear that a deceased's property is available for payment of his debts, notwithstanding that it is subject to a special destination.**

(Clause 34)

References to legal rights in existing documents

9.32 Documents executed under the existing law may refer to legal rights (in the succession law sense) in various contexts. There may, for example, be a renunciation of legal rights by a child in exchange for provisions under a trust. Such references should, once legal shares have replaced legal rights, be construed as references to legal shares. We therefore recommend that:

- 66. In relation to the estate of a person who dies after the commencement of implementing legislation any reference in any document executed before commencement to legal rights (in the succession law sense) should be construed as a reference to the right to claim legal shares under the new legislation.**

(Clause 33)

Part X Private International Law

Introduction

10.1 In memorandum 71 we considered, and sought views on, various questions relating to choice of law in succession matters. Since then the Hague Conference on Private International Law has produced a draft Convention on the Law Applicable to Succession to the Estates of Deceased Persons.¹ As the government will no doubt be considering what the United Kingdom's response to the draft Convention should be, and as it would be undesirable to make changes in Scots law alone at this time, we have decided to make no recommendations on those areas of private international law covered by the draft Convention. For the benefit of those who may be considering this matter at United Kingdom level we merely place on record that our consultation revealed strong support for having one law governing the whole of the succession to a person's estate, without distinction between moveable and immoveable property.

10.2 The draft Convention does not apply to:

- “(a) the form of dispositions of property upon death;
- (b) capacity to dispose of property upon death;
- (c) issues relating to matrimonial property;
- (d) property rights, interests or assets created or transferred otherwise than by succession, such as in joint ownership with right of survival, pension plans, insurance contracts, or arrangements of a similar nature.”²

We are not concerned with matrimonial property in this report but we did deal in memorandum 71 with some of the other points excluded from the scope of the draft Convention and, as the law on them is not always satisfactory, we discuss them below.

Formal validity of wills

10.3 There was no dissent from our preliminary view that the present law on this subject,³ which is itself based on international conventions,⁴ was not in need of change.

Capacity to make and revoke a will

10.4 The present law in Scotland is thought to be that personal capacity to make or revoke a will of moveable property is referable to the law of the testator's domicile at the time of making or revoking, while capacity to make or revoke a will of immoveable property is referable to the law of the situation of the property.⁵ In memorandum 71 we suggested that there was very little merit in having separate rules for moveable and immoveable property in this field and that the law of the testator's

1. At its Sixteenth Plenary Session, October 1988.

2. Art 1(2).

3. Wills Act 1963, s2(b); Administration of Justice Act 1982, ss27-28 and Sch 2.

4. Convention on the Conflict of Laws relating to the Form of Testamentary Dispositions concluded at the Hague on 5 Oct 1961, Convention providing a Uniform Law on the Form of an International Will concluded at Washington on 26 Oct 1973.

5. Anton, *Private International Law* pp519-521, 537. Professor Anton observes (at p520) that “these propositions have been regarded for so long as well settled that there is an absence of judicial authority to vouch them”.

domicile at the time of making or revoking a will should govern his capacity to do so.¹ This was agreed by all who commented on it. We therefore recommend that:

67. Capacity to make or revoke a will should, in the case of a will or revocation executed after commencement of the new legislation, be determined (whether the will disposes of moveables or immoveables or both) by the law of the domicile of the testator at the time of making or revoking the will.

(Clauses 32(1) and 34(5))

Rights of survivor where property in joint names

10.5 The draft Hague Convention does not apply, as we have seen, to property rights arising out of "joint ownership with right of survival".² This is an area where Scots law is in need of an important, but limited, reform. The trouble stems from the case of *Connell's Trs v Connell's Trs*.³ The deceased, a Glasgow businessman, had bought shares in English companies and had had them registered in the joint names of himself and his wife. Under English law, according to the evidence given in the action, the shares would in the circumstances have passed to the survivor. Under Scots law, the deceased's half of the shares would have passed to his executor as part of his estate. It was held that the shares passed to the survivor, the reasoning being that

"he must be taken to have known that the title would carry the shares to the survivor, and to have taken the title with that intention."⁴

Whatever merits this approach may have had on the particular facts of *Connell's Trs*, it does not provide a satisfactory general solution. First the reference to the deceased's intention is dangerous. It would not be satisfactory to base the solution to this type of case on extrinsic evidence of the actual intentions of the person taking the title to property in particular terms.⁵ That would open up endless inconclusive debate. Secondly, it does not seem reasonable to presume that a person investing in foreign shares is aware of the law of the relevant country on survivorship rights in joint holdings or that, even if he were aware of it, that he would wish it to apply. A person purchasing shares may not even know where the company has its registered office. Thirdly, if the quoted words mean that a person must be assumed to know and intend the legal results under the law of England, being the law applicable to the case, of taking shares in an English company in joint names, then they take for granted a particular answer to the very point to be decided, namely whether English law is the applicable law. Fourthly, as a matter of policy it would seem preferable to regard the question whether property passes to someone else on the death of an owner or part owner as a question of succession to be governed by the law of the deceased's domicile.

10.6 *Connell's Trs* was cited, but not applied, in *Dinwoodie's Ex v Carruther's Ex*.⁶ Here two people domiciled and resident in Scotland placed a sum of money on deposit receipt in their joint names with an English bank. It was accepted that by Scots law, on the death of one, the terms of the deposit receipt did not operate to carry his half share to the survivor. It was contended, however, by one party that by the law of England the terms did operate to pass the deceased's property to the survivor and that, under reference to *Connell's Trs*, English law applied. The court held that Scots law applied to the question of the beneficial interest in the fund. Lord Young said:

"I think that the law of England would have to be applied to determine the bank's obligation but there is no question as to that. The question is, who is to have the beneficial interest after the bank's obligation has been determined by payment?"

1. Para 6.14.

2. Art 1(2)(d).

3. (1886) 13 R 1175.

4. At p1185.

5. See *Colenso's Ex v Davidson* 1930 SLT 359 at 361.

6. (1895) 23 R 234.

Now, the law of England had nothing to do with the beneficial interest in the money which has been paid.”¹

10.7 *Connell's Trs* was cited again, but distinguished, in *Cunningham's Trs v Cunningham*.² Here a domiciled Scotsman had purchased War Stock and National War Bonds and had taken the bonds in the joint names of himself and his wife. The bonds were registered with the Bank of England in London. On the man's death, it was argued for his widow that she took the whole of the bonds because English law applied. It was argued for his residuary legatees that the question was one of succession, that the transaction was, in any event, with the United Kingdom or Imperial Government not the Bank of England, and that,

“It would be absurd, in these circumstances, to hold that a Glasgow dairyman transacting with the Imperial Government, should, in a question with his widow, intend the law of England to regulate the rights of parties.”³

The court held that *Connell's Trs* could be distinguished because of the United Kingdom or Imperial nature of the bonds in this case and that Scots law applied. Lord Hunter observed that *Connell's Trs* could not be overruled without convening a larger court but that the question at issue in it was “a difficult question that may have to be considered in some other case.”⁴

10.8 In memorandum 71 we posed the questions whether, in a case where non-Scottish moveable property formed part of the estate of a person dying domiciled in Scotland, Scottish rules of construction should apply to any bequest or title to such property in the absence of any contrary intention in the will or otherwise, and whether the converse should apply in the case of Scottish moveables owned by a person domiciled elsewhere.⁵ Wills would now be covered by the draft Hague Convention and we are therefore concerned here only with the terms of the titles to moveable property—that is, with the *Connell's Trs* type of case. There was general support on consultation for the proposition, although the question was raised whether the law of the domicile at the date of death or at the date of the will or other document should apply. In the case of documents like share certificates there are arguments both ways on this. If the title is deliberately taken in joint names, in the knowledge that the law of the domicile at that time will apply and that it will produce a certain result, and on the assumption that changes in domicile will have no effect on the result, then clearly there is something to be said for applying the law of the domicile at that time. This is a fairly demanding set of assumptions, however, and it must be doubtful whether, in practice, people would act on such a basis. In favour of applying the law of the domicile at the date of death it can be said that this will be more convenient. That is the law which governs moveable succession generally and it will usually be easier to determine what the deceased's domicile was at the date of his death than what it was at some time in the past, perhaps many years before his death. Moreover, there is nothing unacceptable or surprising in the proposition that the law governing the succession to moveable property changes with changes in domicile. Within the limited area of our present concern we think that the balance comes down in favour of the law of the domicile at the time of death. We therefore recommend that:

68. The question whether the terms of the title to moveable property belonging to a deceased person operate to pass that property to anyone else on his death should be determined by the law of the deceased's domicile at the time of his death.

(Clause 32(2))

10.9 We make no similar recommendation for the titles to heritable property. Under the present law the effect of a destination in the title to immovable property is

1. At p 238.

2. 1924 SC 581.

3. At p585.

4. At p589. In the earlier case of *Drysdale's Trs v Drysdale* 1922 SC 741, which concerned National War Bonds in joint names, the same result was reached as in *Cunningham's Trs* but counsel had not argued that English law applied. Again in *Colenso's Ex v Davidson* 1930 SLT 359, which concerned Portsmouth Corporation Stock, the parties were content to let Scots law apply.

5. Para 6.22.

governed by the law of the country where the property is.¹ It may be that this rule would fall to be reconsidered if, as a result of the draft Hague Convention or otherwise, succession to immovables generally were to be governed by the law of the domicile. Until then we think it safer to leave the law as it is.

The Crown's right as *ultimus haeres*

10.10 It may happen that a person dies without any known, or traceable, heirs and that his estate is therefore unclaimed. In these circumstances the estate passes to the Crown who is said to succeed as *ultimus haeres* or "ultimate heir".² This, however, is a misleading description. The Crown does not succeed as an heir. Rather its right is based on the general rule that ownerless property (*bona vacantia*) passes to the Crown. The right is, therefore, regarded as applying to property located in Scotland, no matter where the deceased may have been domiciled. The position is similar in England and Wales.³ The official who takes charge, on behalf of the Crown, of any property of a deceased person which is unclaimed by heirs is called the Queen's and Lord Treasurer's Remembrancer. In memorandum 71 we suggested for consideration that, where the Crown takes property of a deceased person in default of other heirs, it should be regarded as doing so under the law of succession rather than under the law relating to *bona vacantia*.⁴ The result would be that the Crown could claim moveable property abroad belonging to a person who died domiciled in Scotland without any other heirs. There was a mixed response to this on consultation. Most consultees favoured a change, but a few were strongly opposed. The Regional Sheriff Clerks pointed out that, if the Crown were to take as an heir under the ordinary law of succession, the legislation would have to be carefully drafted to ensure that confirmation was not required. The Queen's and Lord Treasurer's Remembrancer saw no need for any change and thought that it would be a retrograde step to create a difference in this area between the law of Scotland and the law of the rest of the United Kingdom. We are persuaded that there is at present no compelling reason to alter the basis on which the Crown takes and that it could be awkward to have the Crown taking on one footing in Scotland and on another in the rest of the United Kingdom. We note that the right of the State where assets are situated is preserved by the draft Hague Convention.⁵ We therefore make no recommendation for change in the substance of the law on this point. We think, however, that it would be undesirable to describe the Crown's right in a new statute by the phrase *ultimus haeres*, which is misleading in that it suggests that the Crown takes as an heir. The draft Bill therefore simply refers to the right of the Crown to any estate unclaimed by heirs.⁶

1. Anton, p533.

2. The Crown's right as *ultimus haeres* is preserved by section 7 of the Succession (Scotland) Act 1964.

3. *In re Barnett's Trusts* [1902] 1 Ch 847; *Re Musurus* [1936] 2 All ER 1666; *In the Estate of Maldonado, Decd* [1954] P 223.

4. Para 6.13.

5. Art 16.

6. Clause 4.

Part XI Consequential Amendments

11.1 Various consequential amendments and repeals will be necessary if the recommendations in this report are implemented. They are set out in the schedules to the attached draft Bill. In most cases they result from matters already discussed. In other cases they are explained in the notes on the clauses or are self-explanatory. The only general point we wish to make here relates to the way in which the draft Bill deals with the Succession (Scotland) Act 1964. We think it would be desirable to repeal Parts I and II of the 1964 Act (intestate succession and legal rights) entirely so that the substantive law on intestate succession and legal shares will all be in the new statute. However, Part III of the 1964 Act on “administration and winding up of estates” should remain for the time being with certain minor alterations. We are planning to issue a discussion paper on executors and that would be the appropriate place in which to examine the whole range of statutory provisions on the administration of estates. Part IV of the 1964 Act (on the effects of adoption in relation to property and succession) would, as we have noted above,¹ be decanted into the adoption legislation where it properly belongs. Part V of the Act (financial provision on divorce) was repealed in 1976 and replaced by provisions in other legislation.² Part VI of the 1964 Act (on miscellaneous and supplemental matters) will remain, although a few provisions in it will be repealed and replaced.³

1. Para 9.2.

2. See now the Family Law (Scotland) Act 1985 ss8 to 18.

3. In particular, s30 (evacuation of special destinations); s31 (presumption of survivorship); s33(1) (references to legal rights in existing deeds).

Part XII Summary of Recommendations

1. Where a person dies intestate survived by a spouse but no issue the spouse should inherit the whole intestate estate.

(Paragraph 2.3; clause 1(2))

2. Where a person dies intestate survived by issue but not by a spouse, the issue should (as under the existing law) inherit the whole intestate estate.

(Paragraph 2.4; clauses 1 and 2)

3.(a) Where a person dies intestate survived by a spouse and issue, the spouse should have a right to £100,000 or the whole intestate estate if less. Any excess over £100,000 should be divided equally, half to the spouse and half to the issue.

(b) The Secretary of State should be given power to alter the figure of £100,000 from time to time by statutory instrument.

(Paragraph 2.7; clause 1)

4. Collaterals of the half-blood should inherit equally on intestacy with collaterals of the full-blood.

(Paragraphs 2.21 to 2.23; clause 1(4))

5. The surviving spouse should continue, as of right, to be entitled to a fixed share of the deceased spouse's estate.

(Paragraphs 3.1 to 3.7; clause 5)

6. The issue of a deceased person should continue, as of right, to be entitled to a fixed share of the deceased's estate.

(Paragraphs 3.8 to 3.12; clause 5)

7. In relation to the legal shares of spouse and issue there should be no distinction between heritable and moveable property.

(Paragraphs 3.15 to 3.16; clauses 5 and 7)

8.(a) The surviving spouse's legal share should be

30% of the first £200,000 of the net estate

10% of any excess of such estate over £200,000.

(b) Where there is no surviving spouse, the issue's legal share should be

30% of the first £200,000 of the net estate

10% of any excess of such estate over £200,000.

(c) Where there is a surviving spouse, the issue's legal share should be

15% of the first £200,000 of the net estate

5% of any excess of such estate over £200,000

but the estate subject to the issue's legal share should not include the first £100,000 of any net estate to the fee of which the surviving spouse succeeds (otherwise than by virtue of a claim for legal share).

(d) Interest should be payable on legal share, where it is claimed, from the date of the deceased's death until payment, at the annual rate of 7% or such other rate as may be prescribed.

(e) The Secretary of State should be given power to alter the above figures of £200,000 or £100,000 from time to time by statutory instrument.

(Paragraphs 3.18 to 3.29; clauses 5(3) and 7)

- 9.(a) Legal share should be due only if claimed by the surviving spouse or issue (or, in cases of incapacity, by anyone entitled to act for him in the management of his affairs) within two years from the date of the deceased's death.
- (b) The court granting a decree of presumed death under the Presumption of Death (Scotland) Act 1977 should have power to extend or alter this time limit so as to allow a claim to be made within such period, not exceeding 6 months from the date of the decree, as the court considers appropriate.
- (c) Where a potential claimant dies within the normal or extended period for making a claim, without having made or renounced a claim, his or her executor should be entitled to make a claim within that period or within the period of 6 months commencing with the potential claimant's death, whichever period ends later.
- (Paragraph 3.30; clauses 5(1) and 6)
- 10.(a) It should be competent to renounce (either during the deceased's lifetime or after his death) the right to claim legal share.
- (b) A renunciation (whether before or after the deceased's death) or a failure to claim legal share within the time limit should not enlarge the legal share of any other potential claimant.
- (Paragraphs 3.31 to 3.33; clauses 5(5) and 7(5))
11. There should be no requirement to collate advances and other benefits as a condition of claiming legal share.
- (Paragraphs 3.34 to 3.37; clause 5(6))
- 12.(a) The amount due by way of legal share should be taken out of the estate in the following order unless the testator provides to the contrary:
- (i) intestate estate
 - (ii) residue
 - (iii) general legacies
 - (iv) special legacies, nominated property and property passing under a special destination.
- (b) This recommendation is subject to the proviso that the estate subject to the issue's legal share should not include the first £100,000 of any property to the fee of which the surviving spouse succeeds (otherwise than by virtue of a claim for legal share).
- (c) Within each of the above categories different items should bear a rateable proportion of legal share according to net value.
- (Paragraph 3.38; clauses 5(3) and 9)
13. Provision should be made, on the lines set out in paragraph 3.42, to enable legal share out of agricultural property to be paid in instalments over a period of not more than ten years.
- (Paragraphs 3.39 to 3.42; clause 11)
14. Subject to any contrary directions by the testator the effect of a claim for legal rights should be as follows.
- (a) A person claiming legal share should forfeit all rights in the deceased's estate under the law of intestate succession and all testamentary provisions from the deceased and all provisions of a quasi-testamentary nature (eg by nomination or survivorship destination).
 - (b) For the purposes of succession to the deceased's estate (otherwise than by way of legal share) the forfeiting claimant should be treated as having predeceased the deceased.
 - (c) A claimant's deemed predecease should not have the effect of enabling anyone to take the forfeited provisions in his place by virtue of representation on

intestacy, or as a conditional institute under the deceased's will, or as a deemed conditional institute.

(Paragraphs 3.45 to 3.48; clause 8)

- 15.(a) The court should be given power to declare to be formally valid a writing which purports to be a will, an alteration to a will, or a revocation of a will, notwithstanding failure to comply with the normal requirements for formal validity, if the court is satisfied (extrinsic evidence being admissible for this purpose) that the testator intended it to take effect as his will, or as an alteration to or revocation of his will.
- (b) Where the court is so satisfied it should make an order to that effect, and the writing would then have effect as if it were formally valid and duly attested.
- (c) The court making an order should have power to make a finding as to the date when, period within which, or place where, the writing was executed or made.
- (d) An application should be competent either as a separate proceeding in the Court of Session or a sheriff court or as an incidental application in other proceedings, including proceedings for the confirmation of an executor.
- (e) Rules of Court should provide for an application to be intimated to persons not already parties but having an interest, including any person who would succeed to any part of the deceased's estate if the application were unsuccessful.
- (f) Provision should be made for the order of the court to be registrable in the Books of Council and Session or sheriff court books if the writing is already registered there or if it is being registered there at the same time.

(Paragraphs 4.1 to 4.20; clause 12)

- 16.(a) Provision should be made for the judicial rectification of a will prepared by someone other than the testator where the court is satisfied that the will is so expressed that it fails to give effect to the testator's instructions.
- (b) The power to rectify should be exercisable by the Court of Session or by the sheriff court.
- (c) An application for rectification should be possible only within 6 months from the date of confirmation of an executor, but the court should have power, on cause shown, to allow a later application.
- (d) A court dealing with an application for rectification should be expressly empowered to consider extrinsic evidence.
- (e) A trustee or executor should not be personally liable for distributing any property in good faith in accordance with a will which is later rectified.
- (f) Provision should be made for a court order rectifying a will to be registrable in the Books of Council and Session or sheriff court books if the will is already registered there or if it is being registered there at the same time.

(Paragraphs 4.21 to 4.28; clause 13)

- 17.(a) Divorce or annulment of marriage should have the effect of revoking
 - (i) any testamentary provision made by one of the spouses in favour of the other (including a provision conferring a power of appointment on the other)
 - (ii) any testamentary appointment by one spouse of the other spouse as a trustee, executor, curator, tutor or donee of a power of appointment
 - (iii) any statutory nomination by one spouse of the other as the person entitled to receive property (such as savings certificates) on his death
 - (iv) any special destination whereby on the death of one spouse the other would succeed to any of that spouse's propertyexcept in so far as the will, nomination or destination indicates that the surviving spouse is to benefit notwithstanding the termination of the marriage by divorce or annulment.

- (b) The effect of a revocation by divorce or annulment should be that the former spouse is deemed, for the purposes of the will or nomination or the succession to the deceased spouse's property or part of the property under the special destination, to have failed to survive the deceased spouse.
- (c) These rules should apply to British divorces or annulments and to foreign divorces or annulments recognised in Scotland.
- (d) The revocation of a special destination by divorce or annulment should not prejudice any person who acquires property, or an interest in it, in good faith and for value, from a person who, so far as the title discloses, has succeeded to that property or interest by virtue of the special destination.
- (e) The Keeper of the Registers of Scotland should not be liable to indemnify any person who suffers loss as a result of the protection afforded by the preceding paragraph.

(Paragraphs 4.34 to 4.45; clause 14)

18. The rule known as the *conditio si testator sine liberis decesserit* (whereby a will may in certain circumstances be held to be revoked by the subsequent birth of a child to the testator) should be abolished.

(Paragraphs 4.46 to 4.49; clause 15)

- 19.(a) There should continue to be a rule whereby, if a legatee within a certain class dies after the date of the will but before the date of vesting, his or her issue take the legacy unless the will expressly, or by clear implication, provides otherwise.
- (b) The rule should be confined to bequests to direct descendants of the testator.
 - (c) The will should be regarded as providing otherwise if the bequest contains an express survivorship clause or destination-over.
 - (d) Where the rule applies, the issue of the predeceasing beneficiary should take the share that the beneficiary would have taken if he (and any other predeceasing beneficiary whose issue take by virtue of the rule) had survived the date of vesting.

(Paragraphs 4.50 to 4.65; clause 17)

20. A will which has been expressly revoked should not revive unless the testator re-executes it or executes another document which expressly revives it.

(Paragraphs 4.67 to 4.76; clause 16)

21. A person who fails to survive for at least five days from the beginning of the day on which a deceased person died should be treated as having failed to survive the deceased person,

- (a) for the purposes of intestate succession to the deceased's estate,
- (b) for the purposes of the legal shares of spouse or children in the deceased's estate,
- (c) unless the will specifies some other period, for the purposes of testate succession to the deceased's estate, and
- (d) for the purposes of succession to the deceased's interest in property which is subject to a special destination.

(Paragraphs 5.1 to 5.4; clause 28)

22. Where two persons die in such circumstances that it cannot be established whether either survived the other by five days or, for purposes of testate succession, by such other period as may be specified in the will, the estate of each should be distributed as if the other had failed to survive him or her for the required period.

(Paragraph 5.5; clause 28(4))

23. Where property is to be transferred to one of two or more persons, depending on the order of their deaths, and does not form part of the estate of either or any

of those persons before his death then if those persons have died simultaneously or in such circumstances that it cannot be established which of them survived the other or others the property or its value should, unless the obligation to transfer contains any provision to the contrary, be divided equally between or among the estates of those persons.

(Paragraph 5.6; clause 28(5))

24. The new rules on survivorship should apply in relation to deaths occurring after the commencement of the new legislation.

(Paragraph 5.7; clause 34(1))

25.(a) A special destination in a future title to property (other than a survivorship destination) should be ineffective in so far as it provides for the succession of persons other than the original grantee or, in the case of a destination containing a survivorship destination, the original grantees and the survivor of them.

(b) This rule should not apply:

(i) to destinations to one person in liferent and another in fee,

(ii) to destinations to a person as a trustee or holder of an office or position and his or her successors as such, or

(iii) to destinations implementing a provision in a will executed before commencement.

(Paragraphs 6.1 to 6.6; clauses 29(1), (2) and 34(4))

26. Where a will, other testamentary document, or trust deed is executed after commencement containing a destination to a beneficiary whom failing another person or persons, that part of the destination relating to the other person or persons should become ineffective as soon as the property in question has vested in the beneficiary.

(Paragraphs 6.8 to 6.9; clause 29(5))

27. A special destination in a deed should be a destination by which the property in question is to devolve upon a named or identified person (or persons) or upon a class of persons (other than "heirs").

(Paragraphs 6.10 to 6.12; clause 36(1) and Schedule 1, paragraph 13)

28. Property subject to a special destination should be excluded from the deceased's estate for the purposes of administration under the Succession (Scotland) Act 1964 (unless a transfer by the executor is necessary) only if, in the circumstances that occur, the property passes by virtue of the special destination.

(Paragraphs 6.13 to 6.14; Schedule 1, paragraphs 12 and 14)

29. A person who succeeds to property by virtue of a special destination should be personally liable for the debts of the previous owner unless he or she renounces the succession. This liability should be limited to the value of the property at the date of the previous owner's death.

(Paragraphs 6.15 to 6.16; clause 29(6))

30.(a) The owner of property subject to a special destination should have power to dispose of it whether for value or gratuitously, either during life or on death, whether or not the destination is contractual in nature, and regardless of who paid for the property.

(b) The above recommendation should apply only to destinations contained in documents executed after the date of commencement of implementing legislation.

(Paragraph 6.18 to 6.22; clauses 29(3) and 34(4))

31. Recommendation 25 should apply to future leases where assignation is permitted without the landlord's consent and to assignments of such leases, but not to other leases or assignments of leases.

(Paragraphs 6.23 to 6.26; clauses 29(1) and (4) and 34(4))

32. Recommendation 30 should apply to future leases where assignation is permitted without the landlord's consent, and to assignments of such leases, but not to other leases or assignments of leases.

(Paragraph 6.27; clauses 29(3) and (4) and 34(4))

33. A destination in an assignment of a lease where assignation is permitted without the consent of the landlord should, as far as the rights of creditors of the assignees are concerned, have the same effect as the same destination in a disposition of feudal property.

(Paragraphs 6.28 to 6.29; clause 29(7))

34.(a) New statutory provisions should be enacted providing that a person who is convicted of the murder, culpable homicide or manslaughter of the deceased by a criminal court in the British Islands or a court-martial should automatically forfeit his or her rights of succession to the deceased's estate and rights to property held in trust devolving on the deceased's death. Where the conviction was that of a foreign court, forfeiture should result if the crime committed would have amounted to murder or culpable homicide had it been committed in Scotland.

(b) The common law principle that an unlawful killer should not receive any benefit from the crime should be retained for cases where there is no conviction or where rights other than rights of succession to the deceased victim's estate or rights to property held in trust are concerned.

(c) No crimes other than murder, culpable homicide or manslaughter, or analogous crimes committed abroad should give rise to forfeiture or otherwise affect Scottish succession rights.

(d) The Parricide Act 1594 should be repealed.

(Paragraphs 7.1 to 7.14; clause 19 and Schedule 2)

35. An unlawful killer who incurs forfeiture should be treated for the purposes of succession to the deceased's estate and any destination of trust property as having predeceased the deceased. Any descendants of the unlawful killer should be entitled to make the same claims on the killer's presumed predecease by virtue of forfeiture as they could have made had the killer actually predeceased without having incurred the penalty of forfeiture.

(Paragraphs 7.15 to 7.18; clause 19(2))

36. There should be a new statutory provision empowering the Court of Session or a sheriff court to authorise a clerk of court to sign any document required to give effect to forfeiture on behalf of a person who refuses or fails to sign.

(Paragraph 7.19; clause 19(6))

37.(a) A person who has, in good faith and for value, acquired title to property or any interest in property from a person who has forfeited or subsequently forfeits that property or interest should have his or her title protected from challenge.

(b) Where the estate of the deceased or a trust suffers loss as a result of such protection the Keeper of the Registers of Scotland should not be required to indemnify it under the Land Registration (Scotland) Act 1979.

(Paragraphs 7.19 to 7.20; clause 19(3) and (4))

38.(a) The Scottish civil courts should continue to have power in appropriate cases to grant relief from forfeiture, but where a person is convicted of murder by a court in the British Islands or a British court-martial an application for relief should be incompetent.

- (b) An application for relief from forfeiture, in a case where the killer has been convicted, should be required to be made within 6 months from the date of the conviction giving rise to forfeiture. Any period during which the conviction may be appealed or is under appeal should not count towards the 6 month period.
 - (c) In granting an application for relief the court should have power to make any necessary ancillary or consequential orders.
(Paragraphs 7.21 to 7.27; clause 20)
- 39.(a) Separation (whether or not a decree of judicial separation has been obtained) should by itself have no effect on the succession rights of spouses in each other's estates.
- (b) Section 6 of the Conjugal Rights (Scotland) Amendment Act 1861 should accordingly be repealed, but without prejudice to the effect of existing decrees.
(Paragraphs 7.28 to 7.33; Schedule 2)
- 40.(a) A surviving spouse who is entitled to a share of intestate estate which includes the deceased's interest in the matrimonial home and furnishings should be given an option to acquire the deceased's interest in them, in satisfaction or part satisfaction of his or her entitlement. Where the value of the interest exceeds the value of the spouse's entitlement on intestacy, the spouse should still be entitled to acquire on paying the excess to the estate.
- (b) A similar option should be given to a surviving spouse where the home or furnishings are part of the residue of the estate of which the spouse is a beneficiary.
 - (c) There should be no option to acquire where the home is part of property tenanted by the deceased, or where the home is part of a larger business property whose value would be substantially diminished by splitting off the home.
 - (d) Where the estate includes an interest in more than one matrimonial home and furnishings, the surviving spouse's option to acquire should be limited to one home and one set of furnishings. The spouse should be entitled to elect which home and furnishings (not necessarily in the home sought to be acquired) he or she wishes to acquire.
 - (e) The surviving spouse should have no option to acquire heirlooms of the deceased's family.
(Paragraphs 8.1 to 8.8; clause 23)
- 41.(a) The surviving spouse should be entitled to acquire the home and furnishings only if he or she intimates an intention to acquire not later than six months after confirmation.
- (b) Intimation of the intention to acquire should be given by the surviving spouse to the executors, or if the surviving spouse is the sole executor, to all those beneficiaries whose interests in the estate would be financially affected by the value at which the spouse acquired the assets and who can be identified and traced after reasonable inquiries have been made.
 - (c) The acquisition value should be either agreed by the surviving spouse, the executors, and the interested beneficiaries or set by an arbiter. The arbiter should be appointed by agreement or failing agreement by the sheriff principal of the sheriffdom in which the deceased died domiciled. Where the sheriffdom is uncertain or the deceased died domiciled furth of Scotland, the arbiter should be appointed by the sheriff principal of the Lothians and Borders.
 - (d) The arbiter should value the items sought to be acquired at their open market value at the date when the spouse intimated the intention to acquire them.
 - (e) An acquisition of the home or furnishings under the above procedures by a surviving spouse who is an executor or the sole executor, should not be voidable as a transaction *in rem suam*.
(Paragraphs 8.9 to 8.14; clause 23)

42. A trustee or executor in making a distribution from the estate vested in him or her should not be personally liable for any error in distribution based on ignorance of the existence or non-existence of persons or their relationship or lack of relationship with a relevant person (including relationships by adoption or marriage) provided that he or she acted in good faith and made such enquiries as a reasonable and prudent trustee or executor would make in such circumstances.

(Paragraphs 8.15 to 8.18; Schedule 1, paragraph 7)

43. Without prejudice to section 23 of the Sale of Goods Act 1979 (protection of good faith purchasers of goods for value against seller's voidable title), section 17 of the Succession (Scotland) Act 1964 should be extended so as to protect persons acquiring (whether by purchase or otherwise) from the executor, or a third party deriving title from the executor, any executry assets in good faith and for value.

(Paragraphs 8.19 to 8.20; Schedule 1, paragraph 11)

44. It should continue to be competent for an executor or trustee to use the deceased's will as a link or warrant for deducing or completing title to the deceased's heritage. This facility should be extended to legatees or general disponees under the will.

(Paragraphs 8.21 to 8.22; Schedule 1, paragraph 4)

45.(a) It should cease to be competent to appoint a person as executor-dative to the estate of a deceased person merely on the ground of being within the archaic and restrictive common law definition of "next-of-kin" to the deceased.

(b) Any relative of a deceased person should be entitled to apply for appointment as executor-dative to the deceased.

(c) For this purpose, a "relative" should mean any person entitled to succeed to the deceased on intestacy or, if no such person is to apply, any blood relative.

(d) If more than one relative applies, the sheriff should, unless there is good reason not to do so, appoint the one most closely related to the deceased. Where the applicants are equally closely related the sheriff may appoint one, some or all of them.

(Paragraphs 8.23 to 8.25; Schedule 1, paragraph 2)

46. Section 1 of the Confirmation of Executors (Scotland) Act 1823, having been superseded by later enactments and practice, should be repealed.

(Paragraphs 8.26 to 8.27; Schedule 2)

47. Jurisdiction should be conferred on Scottish courts to grant confirmation to executors of a person who died domiciled in Scotland, even where there is no estate situated in Scotland.

(Paragraph 8.28; clause 21 and Schedule 2)

48. Unless the court allows a restriction of caution, the sum for which a bond of caution should be granted should be the full gross value of the estate to be administered by the executor.

(Paragraph 8.36; Schedule 1, paragraph 1)

49. A surviving spouse appointed as executor-dative should, as at present, not be required to find caution before confirmation where the deceased died intestate and the spouse is entitled to the whole estate.

(Paragraph 8.38; Schedule 1, paragraph 1)

50.(a) Where an interest of a deceased tenant under a lease is to be transferred under section 16 of the Succession (Scotland) Act 1964 the executor should determine the value of the interest and intimate it to the proposed transferee and those whose share of the estate would be financially affected by the value placed on the interest, provided that they can be identified and traced after reasonable enquiries have been made. In the event of the executor, the proposed transferee, and the others financially interested failing to agree on

the executor's value (or any other value) the value should be determined by the Scottish Land Court (where the lease was of an agricultural holding or a croft) or the Lands Tribunal for Scotland (for other cases).

- (b) An executor should be entitled to transfer the interest to himself or herself as an individual, provided the above procedure is used.

(Paragraphs 8.40 to 8.46; clause 22)

51. Where an executor transfers the deceased's interest in a lease under section 16 of the Succession (Scotland) Act 1964 to a person and the value of the interest (as determined by the Land Court or the Lands Tribunal for Scotland in default of agreement) exceeds the value of that person's entitlement or claim to a share of the estate, that person should be under an express statutory obligation to pay to the estate a sum being the value of the interest less the value of the entitlement or claim.

(Paragraph 8.47; clause 22)

52. To avoid any possibility of a doubt as to the extent to which an adopted child is regarded as included in his adoptive family for the purposes of section 23(2) of the Succession (Scotland) Act 1964,

- (a) the words "or issue" should be inserted after the word "children" in paragraphs (a) and (b) of that subsection, and

- (b) the words "or way" should be added after the word "degree" in both places where it appears in paragraph (c) of that subsection.

(Paragraph 9.1; Schedule 1, paragraph 20)

53.(a) The statutory provisions on the effect of adoption on succession and the disposal of property under *inter vivos* deeds should be grouped together and placed in the appropriate part of the Adoption (Scotland) Act 1978.

- (b) Section 24(1A) of the Succession (Scotland) Act 1964 (relative seniority of adopted child to depend on date of adoption rather than actual age) should, however, be repealed and not re-enacted.

(Paragraph 9.2; Schedule 1, paragraphs 19 and 20)

54. The rule of law entitling the family of a deceased person to an allowance from his estate for mournings should be abolished.

(Paragraph 9.3; clause 25)

55. Aliment *ex jure representationis* should be abolished. Accordingly it should no longer be possible for a person entitled to aliment from another person to claim, after that person's death, aliment from that person's executor or from anyone enriched by the succession to that person's estate.

(Paragraphs 9.4 to 9.5; clause 27)

56. The right of certain relatives to claim temporary aliment out of a deceased's estate should be abolished.

(Paragraphs 9.6 to 9.10; clause 26)

57. It should be made clear that the abolition of challenges and reductions on the ground of deathbed extends to all transactions, whether or not effected in writing.

(Paragraph 9.11; clause 31)

58.(a) Donations *mortis causa* should not be deemed to be part of the donor's estate for the purpose of the legal share of spouse or issue. Accordingly legal share should not be claimable out of them and they should not be forfeited by a person making a claim.

- (b) Donations *mortis causa* should be returnable not only (as under the present law) if the donee fails to survive the donor but also if

- (i) the donee incurs forfeiture as a result of having unlawfully killed the donor, or

- (ii) the donee fails to survive the donor by five days.
(Paragraphs 9.12 to 9.16; clauses 19(1), 28(8) and 36(1))

59. Where property has been left to one person in life and another person in fee, and the life tenant is forfeited or renounced by the life tenant, or otherwise terminates before the life tenant's death, then the fee should, unless the document creating the life tenancy expressly provides otherwise, vest in the fee owner at the time when it would have vested if the life tenant had died on the date of the forfeiture, renunciation or termination.

(Paragraph 9.17; clause 18)

60. A renunciation of the right to claim, or a failure to claim, legal share should not be a transfer of value for the purposes of the Inheritance Tax Act 1984.

(Paragraphs 9.18 to 9.19; Schedule 1, paragraph 24)

61. Section 42 of the Inheritance Tax Act (treatment of legal rights for purposes of allocation of exemptions) should be amended to include a reference to legal share under the new legislation.

(Paragraph 9.20; Schedule 1, paragraph 25)

62. A provision should be added to the Inheritance Tax Act 1984 to the effect that where legal share is claimed within the permitted period after the deceased's death the Act should apply as if the amount taken by way of legal share had been bequeathed by the deceased to the claimant.

(Paragraph 9.21; Schedule 1, paragraph 26)

63.(a) For the purposes of the new rules on intestate succession and legal share the "net estate" forming the basis of division should be the estate belonging to the deceased at the date of his death less

- (i) the debts for which his estate is liable as at the date of his death; and
- (ii) any funeral expenses.

(b) Inheritance tax and expenses of administration should not be deducted before the division is made but this should not carry any implication that the estate is not liable for inheritance tax and expenses of administration or that the amounts due to beneficiaries in accordance with the rules of division applying to the net estate will not ultimately have to bear a share of that tax or those expenses.

(c) For the purposes of allocating expenses of administration to different parts of the estate any amount payable by way of legal share should be treated as if it had been a legacy of the same amount.

(Paragraphs 9.23 to 9.25; clauses 10 and 36)

64. The rule that, where items of a deceased's estate which are not capable of accurate valuation at the date of death are realised in the ordinary course of administration without undue delay after his death, the realised value is substituted for the estimated value as at the date of death should be enacted in statutory form.

(Paragraph 9.27; clause 24)

65.(a) In general the new rules of succession law recommended in this report should apply only in relation to deaths occurring after the commencement of implementing legislation ("commencement").

(b) Where it is uncertain whether a person died before or after commencement he or she should be deemed to have died after commencement.

(c) Where a person dies after commencement, leaving an imperfectly executed will, or alteration to a will, it should be possible to have the will or alteration validated under clause 12 of the draft Bill even if it was made before commencement.

(d) Where a person dies after commencement leaving a will which fails to carry out his instructions it should be possible to rectify the will under clause 13 of the draft Bill even if it was made before commencement.

- (e) The recommended new rules on what happens to a bequest to a descendant if he or she predeceases the testator leaving issue, and the recommended new rules on special destinations should not affect documents executed before commencement. This should not apply, however, to the rules designed simply to make it clear that a deceased's property is available for payment of his debts, notwithstanding that it is subject to a special destination.
(Paragraphs 9.28 to 9.31; clause 34)

66. In relation to the estate of a person who dies after the commencement of implementing legislation any reference in any document executed before commencement to legal rights (in the succession law sense) should be construed as a reference to the right to claim legal shares under the new legislation.
(Paragraph 9.32; clause 33)

67. Capacity to make or revoke a will should, in the case of a will or revocation executed after commencement of the new legislation, be determined (whether the will disposes of moveables or immoveables or both) by the law of the domicile of the testator at the time of making or revoking the will.
(Paragraph 10.4; clauses 32 and 34(5))

68. The question whether the terms of the title to moveable property belonging to a deceased person operate to pass that property to anyone else on his death should be determined by the law of the deceased's domicile at the time of his death.
(Paragraphs 10.5 to 10.8; clause 32(2))

Matters Which We Have Consulted Upon And Where We Recommend No Change

1. A surviving spouse should continue to have the same rights on intestacy whether or not he or she is the parent of all the deceased's children.
(Paragraphs 2.10 to 2.17)
2. There should be no change in the existing rules of division of an intestate estate where the deceased leaves neither spouse nor issue but is survived by one or both parents and one or more brothers or sisters (or their issue). Accordingly the surviving parent or parents should continue to be entitled to one half of the estate and the surviving brothers or sisters (or their issue) to the other half.
(Paragraphs 2.18 to 2.20)
3. There should be no change in the existing system whereby when ascendants or collaterals of ascendants succeed to the deceased's intestate estate they take equally without regard to whether they are from the mother's or father's side of the family.
(Paragraph 2.25)
4. New rules should not be introduced for the division of intestate estate among issue of the deceased or issue who represent a predeceasing relative.
(Paragraph 2.27)
5. As under the present law, relatives however remote should be entitled to succeed to the deceased's intestate estate in the absence of nearer heirs.
(Paragraph 2.28)
6. The courts should not be empowered to order provision to be made out of the

estate of a deceased person to applicants who are left inadequately provided for under the deceased's will or the rules of intestacy.

(Paragraphs 3.13 to 3.14)

7. Measures to counteract lifetime transactions designed to avoid or lessen claims to legal share should not be introduced.

(Paragraphs 3.49 to 3.54)

8. There should be no change in the present law whereby a will is not revoked by the testator's subsequent marriage.

(Paragraph 4.33)

9. In view of our recommendation that a court should have power to validate unauthenticated alterations to a will, there should be no change in the law of conditional revocation (deletion of words may be conditional upon substituted words taking effect).

(Paragraph 4.77)

10. Neither the courts nor curators bonis should be empowered to make a will for a person who lacks testamentary capacity.

(Paragraphs 4.78 to 4.80)

11. A new statutory provision should not be introduced setting out the meaning of "heirs" in private documents.

(Paragraphs 4.81 to 4.83)

12. When Scottish rules of construction apply to a title to property held in the name of two or more persons there should not be a deemed destination to the survivor or survivors.

(Paragraph 6.7)

13. Partial confirmation should not be introduced. Accordingly executors should continue to be required to submit a full inventory of the deceased's estate when applying for confirmation.

(Paragraphs 8.29 to 8.31)

14. Executors-dative (other than a surviving spouse who succeeds to the deceased's whole intestate estate) should continue to be required to find caution before being confirmed.

(Paragraphs 8.32 to 8.34)

15. Executors-nominate should continue to be exempt (save in exceptional circumstances) from a requirement to find caution before being confirmed.

(Paragraph 8.35)

16. New procedures for restricting or dispensing with caution should not be introduced.

(Paragraph 8.37)

17. There should be no change in the Crown's right to estate in Scotland which is not claimed by any heirs of the deceased.

(Paragraph 10.10)

SUCCESSION (SCOTLAND) BILL

ARRANGEMENT OF CLAUSES

PART I

INTESTATE SUCCESSION

Clause

1. General rules.
2. Representation.
3. Division of net intestate estate among several claimants.
4. Saving of right of Crown to unclaimed estate.

PART II

LEGAL SHARE OF SPOUSE AND ISSUE IN DECEASED'S ESTATE

5. General rules.
6. Making of claims.
7. Amount payable to spouse or issue.
8. Effect of claim on other rights of succession.
9. Incidence of spouse's and children's legal shares.
10. Liability of claimant for administration expenses.
11. Payment by instalments out of agricultural property.

PART III

TESTAMENTARY DOCUMENTS

12. Validation of documents not executed or imperfectly executed.
13. Rectification of wills.
14. Effect of divorce or annulment of marriage on wills and special destinations.
15. Abolition of rule that subsequent birth of child may revoke will.
16. Revival of revoked wills.
17. Beneficiary predeceasing leaving issue.
18. Vesting of fee on termination of liferent.

PART IV

FORFEITURE OF KILLER'S RIGHTS OF SUCCESSION

19. Forfeiture and effect of forfeiture.
20. Relief from forfeiture except in case of murder conviction.

PART V

ADMINISTRATION OF ESTATES

21. Confirmation to be competent where no estate in Scotland.
22. Provisions relating to leases.
23. Surviving spouse's right to acquire matrimonial home and contents.

24. Valuation of estate.
25. Abolition of mournings.
26. Abolition of rule enabling payment of temporary aliment out of deceased's estate.
27. Aliment payable by deceased not to be payable by executor or successor.

**PART VI
SURVIVORSHIP**

28. Survivorship.

**PART VII
DESTINATIONS**

29. Destinations.

**PART VIII
MISCELLANEOUS AND GENERAL**

30. Right of tenant to bequeath interest under lease.
31. Challenge of acts on deathbed.
32. Private international law.
33. Construction of existing documents.
34. Transitional provisions.
35. Regulations.
36. Interpretation and exclusion from operation of Act.
37. Amendments and repeals.
38. Short title, commencement and extent.

SCHEDULES:

- | | |
|------------|------------------------------------|
| Schedule 1 | Minor and Consequential Amendments |
| Schedule 2 | Enactments Repealed |

DRAFT
OF A
BILL
TO

A.D. 1990.

Amend the law of Scotland with respect to the succession to, and the administration of, the estates of deceased persons and with respect to the validation and rectification of wills; to amend the law relating to the rights arising from a trust which takes effect during the lifetime of the truster and relating to the devolution of property under a destination; to re-enact with amendments certain provisions relating to adopted persons; and for connected purposes.

BEIT ENACTED by the Queen's most Excellent Majesty, by and with the advice and consent of the Lords Spiritual and Temporal, and Commons, in this present Parliament assembled, and by the authority of the same, as follows:—

PART I

INTESTATE SUCCESSION

General rules.

1.—(1) The net intestate estate of a deceased person shall be divided in accordance with the provisions of this Part of this Act.

(2) Where the deceased is survived by a spouse, then—

(a) if—

- (i) the deceased is not also survived by issue; or
- (ii) the net intestate estate is not more than £100,000 or such other sum as may be prescribed,

the surviving spouse shall be entitled to the whole of the net intestate estate;

(b) subject to the following provisions of this Part of this Act, if the deceased is also survived by children and the net intestate estate exceeds £100,000 or such other sum as may be prescribed—

- (i) the surviving spouse shall be entitled to the first £100,000 or such other sum as may be prescribed, and one half of the net intestate estate in so far as it exceeds that sum; and
- (ii) the children shall be entitled to the other half of that excess.

EXPLANATORY NOTES

Clause 1

General

This clause sets out the new rules of intestate succession. "Net intestate estate" is defined in Clause 36(1) by reference to the whole estate of whatever kind belonging to the deceased at the date of death. Heritable and moveable estate within the scope of the Bill (see Clause 32(3) saving the existing rules of private international law) are aggregated together and the combined total devolves in accordance with the new rules.

"Spouse" includes a spouse separated under a decree of judicial separation except where the decree was granted before the date of the commencement of the Bill's provisions (see Schedule 2, repeal of the Conjugal Rights (Scotland) Amendment Act 1861). Where the decree was granted before commencement a husband has no rights of succession to his wife's intestate estate which she acquired after the decree.

Subsection (2)

Paragraph (a) implements Recommendations 1 and 3(a). The surviving spouse will inherit the entire intestate estate where the deceased leaves no children or remoter descendants or, even if children or remoter descendants survive, where the estate does not exceed £100,000 or such other sum as may be prescribed by the Secretary of State.

Paragraph (b) implements the remainder of Recommendation 3(a). Where the deceased leaves a spouse and issue the issue inherit only one half of any excess over £100,000 or other prescribed sum, the spouse taking the remainder. Although the paragraph refers to survival by children, it also covers the situation where all the children have predeceased leaving remoter descendants who survive the deceased because of the effect of representation in Clause 2.

- (3) Subject to the following provisions of this Part of this Act, where the deceased is not survived by a spouse, then—
- (a) if the deceased is survived by children, they shall be entitled to the whole of the net intestate estate;
 - (b) if the deceased is survived by either of, or both, his parents, and is also survived by brothers or sisters, but is not survived by any prior relative, the surviving parent or parents shall be entitled to one half of the net intestate estate and the surviving brothers and sisters to the other half thereof;
 - (c) if the deceased is survived by brothers or sisters, but is not survived by any prior relative, the surviving brothers and sisters shall be entitled to the whole of the net intestate estate;
 - (d) if the deceased is survived by either of, or both, his parents, but is not survived by any prior relative, the surviving parent or parents shall be entitled to the whole of the net intestate estate;
 - (e) if the deceased is survived by uncles or aunts (being brothers or sisters of either parent of the deceased), but is not survived by any prior relative, the surviving uncles and aunts shall be entitled to the whole of the net intestate estate;
 - (f) if the deceased is survived by a grandparent or grandparents (being a parent or parents of either parent of the deceased), but is not survived by any prior relative, the surviving grandparent or grandparents shall be entitled to the whole of the net intestate estate;
 - (g) if the deceased is survived by brothers or sisters of any of his grandparents (being a parent or parents of either parent of the deceased), but is not survived by any prior relative, those surviving brothers and sisters shall be entitled to the whole of the net intestate estate;
 - (h) if the deceased is not survived by any prior relative, the ancestors of the deceased (being remoter than grandparents) generation by generation successively shall be entitled to the whole of the net intestate estate; so however that, failing ancestors of any generation, the brothers and sisters of any of those ancestors shall be entitled thereto before ancestors of the next more remote generation.
- (4) In subsection (3) above—
- (a) references to brothers or sisters include respectively brothers and sisters of the half blood as well as of the full blood; and
 - (b) “prior relative”, in relation to any class of person mentioned in any paragraph of that subsection, means a person of any other class who, if he had survived the deceased, would have been entitled to the net intestate estate or any of it by virtue of any earlier paragraph of that subsection or by virtue of any such paragraph and section 2 of this Act.
- (5) For the purposes of this Part of this Act, where a person has renounced a right to any net intestate estate, the person so renouncing shall be regarded as having failed to survive the deceased in relation to the right so renounced.

Representation.

2.—(1) This section applies where a person (“the predeceasing person”) has failed to survive a deceased person who has died leaving net intestate estate and the predeceasing person would by virtue of section 1 of this Act have been entitled to the whole or any part of the net intestate estate if he had survived the deceased person.

(2) Where this section applies and the predeceasing person has left issue who survive the deceased person, the issue shall have the same right in the net intestate estate as the predeceasing person would have had if he had survived the deceased person.

EXPLANATORY NOTES

Subsection (3)

This subsection deals with the order of succession where the deceased does not leave a spouse. The order is the same as in the Succession (Scotland) Act 1964.

Paragraph (a) refers to children, but Clause 2 provides that surviving issue of a predeceasing child take the share that would have fallen to the predeceasing child had he or she survived the deceased. It implements Recommendation 2.

Paragraphs (b),(c) and (d) continue the existing law whereby if the deceased is survived by a parent or parents and siblings (or surviving issue representing predeceasing siblings) the estate is split equally between these two groups. Further division within each group is governed by Clauses 2 and 3.

Paragraphs (e) to (g) follow the existing rules in terms of which the order of succession is uncles and aunts (or their issue), grandparents, great uncles and great aunts (or their issue).

Paragraph (h) retains the principle of an infinite search for heirs. Relatives however distant remain entitled to succeed in the absence of nearer relatives.

Subsection (4)

Paragraph (a) implements Recommendation 4 giving collaterals of the half blood the same rights as collaterals of the full blood.

Subsection (5)

This subsection states expressly the effect of a renunciation (in whole or in part) by any intestate successor. Under the 1964 Act the effect had been open to doubt.

Clause 2

General

This clause provides for representation of relatives who predecease the deceased leaving issue who survive the deceased. It reproduces the existing law (Succession (Scotland) Act 1964, section 5(1)).

- (3) In this section “the predeceasing person” does not include a direct ascendant or spouse of the deceased person.
- (4) The foregoing provisions of this section are subject to section 3 of this Act.

Division of net
intestate estate
among several
claimants.

3.—(1) If, by virtue of section 1(2)(b)(ii), 1(3) or 2 of this Act, there are two or more persons entitled among them to the whole or to a part of a net intestate estate, then the said estate, or, as the case may be, that part thereof, shall—

- (a) if all of those persons are in the same degree of relationship to the deceased, be divided among them equally; and
- (b) in any other case, be divided equally into a number of portions equal to the aggregate number of—
- (i) the nearest surviving relatives, that is to say those persons who are nearest in degree of relationship to the deceased; and
- (ii) the nearest predeceasing relatives, that is to say any other persons who were related to the deceased in that degree, but who have failed to survive him leaving issue who survive him;

and of those portions, one shall be taken by each of the nearest surviving relatives, and one shall be taken in accordance with subsection (2) below by the surviving issue of each of the nearest predeceasing relatives.

(2) Where the issue of a nearest predeceasing relative consist of two or more persons, the portion to which they are entitled shall be shared between or among them as follows—

- (a) the portion shall be divided equally into a number of parts equal to the aggregate number of—
- (i) any children of that relative who survive the deceased; and
- (ii) any children of that relative who have failed to survive the deceased leaving issue who survive him;

and of those parts, one shall be taken by each of the surviving children (if any), and one shall be taken in accordance with paragraph (b) below by the surviving issue of each predeceasing child (if any);

- (b) if the surviving issue of a predeceasing child referred to in paragraph (a) above consist of two or more persons, paragraph (a) above shall, subject to any necessary modification, have effect for the purpose of determining the amount of the part to be taken by each of those persons; and
- (c) the amount of the deceased’s net intestate estate to be taken by surviving issue of descendants of the deceased of remoter generations who predecease the deceased shall be determined in like manner.

Saving of right of
Crown to
unclaimed estate.

4. Nothing in this Part of this Act shall be held to affect the right of the Crown to any estate unclaimed by heirs.

EXPLANATORY NOTES

Subsection (3)

There is no representation for a predeceasing spouse because such representatives are either the deceased's own issue (who have independent rights of succession under Clause 1) or step-relatives (who have no rights of succession on intestacy). The position of representatives of direct ancestors is similar.

Clause 3

This clause sets out how the estate or part of it is to be divided where there are two or more people entitled to share it. Where the deceased is survived by a spouse and issue and the estate is large enough for issue to be entitled to part of it this clause deals with the division of the issue's part amongst them. It does not deal with the division between spouse and issue as that division is dealt with in Clause 1(2)(b).

Clause 3 restates the existing law contained in section 6 of the Succession (Scotland) Act 1964 but in a slightly different form (see paragraphs 2.24 to 2.27 of the report). The rules of division amongst the issue of predeceasing relatives are set out in full instead of by referring to division "*per stirpes*" as in the 1964 Act.

Clause 4

This clause restates the existing law. It provides for the disposal of intestate estate which is not claimed by any heirs entitled to it under Clauses 1 to 3. The Crown ingathers the unclaimed estate and holds it subject to the claims of emergent creditors and heirs. The right of an heir to come forward and claim is cut off by the long negative prescription (20 years), under section 7 of the Prescription and Limitation (Scotland) Act 1973.

PART II

LEGAL SHARE OF SPOUSE AND ISSUE IN DECEASED'S ESTATE

General rules.

5.—(1) Subject to the provisions of this Part of this Act, a surviving spouse or surviving issue of a deceased person shall be entitled to a share in his net estate, but only if the spouse or issue (as the case may be) claims the share.

(2) Any share referred to in subsection (1) above shall be known as “the spouse’s legal share” or “the children’s legal share”, as the case may be.

(3) Where there is a surviving spouse, then, for the purpose of calculating the amount of any claim by surviving issue under section 7 of this Act or of ascertaining the incidence thereof under section 9 of this Act, the net estate of the deceased shall not include the first £100,000 or such other sum as may be prescribed of any of the net estate to the fee of which the spouse succeeds otherwise than by virtue of a claim by the spouse under this Part of this Act.

(4) Where a surviving spouse succeeds to estate falling into more than one of the following categories—

- (a) special legacies;
- (b) general legacies;
- (c) residue;
- (d) net intestate estate;

the sum referred to in subsection (3) above shall be ascribed to those categories in the order in which they are mentioned.

(5) It shall be competent—

- (a) during the lifetime of the deceased; or
- (b) after his death,

for a person to renounce any entitlement he may have to make a claim to the spouse’s legal share or the children’s legal share out of the deceased’s net estate.

(6) *Jus relictii*, *jus relictæ* and *legitim*, and any ancillary rules of law relating thereto, are hereby abolished.

EXPLANATORY NOTES

Clause 5

General

This clause, together with the rest of Part II, replaces the common law system of legal rights (*jus relictæ*, *jus relictî* and *legitim*) by new statutory rights of protection against disinheritance called legal share. It implements Recommendations 5 to 11. Legal share is claimable by the surviving spouse and descendants of the deceased out of his or her estate.

Subsections (1) and (2)

These subsections implement Recommendations 5 and 6. Like legal rights the new legal shares are calculated according to fixed rules based on the value of the net estate, and are available only to the deceased's surviving spouse and issue. A surviving spouse includes a separated spouse, whether decree was granted before or after commencement, but not one whose marriage to the deceased was annulled or terminated by divorce.

Unlike legal rights, which are due out of moveable estate only, legal share is calculated by reference to the whole net estate, heritable and moveable (see Clause 36(1) for the definition of net estate). Another major difference is that the legal share does not vest in the spouse and issue on survivance of the deceased. It has to be claimed.

In spite of its name, children's legal share may be claimed by the issue of predeceasing children who survive the deceased.

Subsection (3)

Issue are not entitled to claim legal share from the first £100,000 of the net estate to the fee of which the surviving spouse succeeds, other than by way of legal share. Ways in which the surviving spouse succeeds include, by virtue of provisions in the deceased's will, under the rules of intestacy, or by way of special destination or nomination. This implements Recommendation 8(c) in part. The figure of £100,000 or such other sum as may be prescribed (the same as the spouse's preferential claim on intestacy under Clause 1(2)) is chosen so as to ensure that a surviving spouse is never worse off under a will leaving him or her the entire estate than on intestacy.

A liferent to the surviving spouse does not prevent issue claiming legal share out of the fee. The issue may claim legal share out of the whole estate if the spouse forfeits his or her rights in the estate by claiming legal share (see Clause 8(1)).

Subsection (4)

Where the surviving spouse succeeds to more than one category of estate then for the purposes of calculating which part(s) of the estate will bear children's legal share (see Clause 9) it is necessary to decide how to allocate the spouse's £100,000 (or other amount) of estate exempt from children's legal share under subsection (3) between the categories of estate to which he or she succeeds.

Subsection (5)

This implements Recommendation 10(a). A lifetime renunciation may be part of an estate planning exercise or may be sought by the deceased in return for a substantial gift. A renunciation after death allows the executors to distribute the estate without waiting for the period for making a claim to expire.

Subsection (6)

This subsection abolishes the right to claim *jus relictæ*, *jus relictî* or *legitim* from the estate of a person dying after the coming into force of any legislation implementing the Bill's provisions.

One of the ancillary rules abolished is collation. If two or more children claim *legitim* each has to add back to the estate from which *legitim* is due particular types of advances made to them by the deceased during his or her lifetime and offset such advances against the value of their claims. A spouse is not required to collate on claiming legal rights. Abolition of collation implements Recommendation 11 and ensures that such rules do not apply to the new children's legal share.

Other ancillary rules abolished are those which regulate which part of the estate legal rights are payable out of and the liability of persons taking legal rights for administration expenses. Clauses 9 and 10 respectively contain new provisions for these matters in connection with legal share.

Making of claims.
1977 c.27.

6.—(1) Subject to section 2(2A) of the Presumption of Death (Scotland) Act 1977 and subsection (4) below, a claim to the spouse's legal share or the children's legal share shall be ineffective unless it is made within a period of 2 years commencing with the date of the deceased's death.

(2) Where a person is under legal disability by reason of nonage or otherwise, such a claim as aforesaid or a renunciation under section 5(5) of this Act may be made on that person's behalf by a person entitled to act for him in the management of his affairs.

(3) A judicial factor shall be entitled to make such a claim without having to obtain special powers from the court to enable him to do so.

(4) Subject to the said section 2(2A), if the spouse or issue has died, without such a claim being made or without the renunciation of an entitlement to make such a claim, within the said period of 2 years or, as the case may be, the period specified as appropriate by the court under the said section 2(2A), the executor of the spouse or issue shall be entitled to make such a claim within—

(a) the said period of 2 years; or

(b) the period of 6 months commencing with the date of death of the spouse or issue (as the case may be),

whichever period finishes later.

(5) Any reference in this Part of this Act to a claimant is a reference to the person making a claim on his own behalf under this Part of this Act or (as the case may be) the person on whose behalf such a claim is made.

(6) In section 2 of the Presumption of Death (Scotland) Act 1977, after subsection (2) there shall be inserted the following subsection—

“(2A) The court, in granting decree under subsection (1) above, shall have power, if—

(a) the period of 2 years specified in section 6(1) of the Succession (Scotland) Act 1990 within which a claim may be made under Part II of that Act out of the deceased's net estate has expired; or

(b) less than 6 months of that period remains unexpired, to authorise such a claim to be made within such period, not exceeding 6 months commencing with the date of the decree, as the court thinks appropriate.”.

EXPLANATORY NOTES

Clause 6

Subsection (1)

Unlike existing legal rights, which vest in the spouse and issue on the deceased's death, legal share will have to be claimed within a certain period of the deceased's death.

Subsection (2)

This subsection implements Recommendation 9(a). A claim for legal share, or a renunciation of the right to claim legal share out of the deceased's estate (either made during the deceased's lifetime or after the deceased's death), may be made by a parent on behalf of a pupil child, a curator bonis on behalf of a mentally incapacitated adult, an executor on behalf of a deceased claimant, or a non-Scottish financial guardian or manager on behalf of the person whose estate is under management.

Subsection (3)

This subsection entitles the curator bonis of a mentally incapacitated claimant or other judicial factor to claim legal share without having to apply to the court for authority to do so. The normal powers of a curator bonis do not include power to choose between legal rights and testamentary provisions.

Subsection (4)

Where a potential claimant for legal share dies within the 2 year period, or the period in subsection (6), without having claimed, his or her executor might have insufficient time to make a claim. This subsection ensures that the executor has at least 6 months in which to decide whether or not to claim. It implements Recommendation 9(c).

Subsection (6) This subsection provides another exception to the general rule in subsection (1) that a claim for legal share must be made within 2 years of the deceased's death. It implements Recommendation 9(b). Without the extension provided, a spouse or issue would be unable to claim legal share where the court in a decree under the Presumption of Death (Scotland) Act 1977 declared the deceased to have died more than 2 years previously.

Amount payable
to spouse or issue.

7.—(1) The amount payable by way of the spouse's legal share out of the net estate of the deceased shall be (whether or not the deceased is survived by issue)—

- (a) 30% of the first £200,000 or such other sum as may be prescribed;
- (b) 10% of that estate in so far as it exceeds that sum.

(2) Subject to subsections (3) and (4) below, the amount payable by way of the children's legal share to a claimant out of the net estate of the deceased shall be—

- (a) if the deceased is not survived by a spouse—
 - (i) 30% of the first £200,000 or such other sum as may be prescribed; and
 - (ii) 10% of that estate in so far as it exceeds that sum.
- (b) subject to section 5(3) of this Act, if the deceased is survived by a spouse—
 - (i) 15% of the first £200,000 or such other sum as may be prescribed; and
 - (ii) 5% of that estate in so far as it exceeds that sum.

(3) Where two or more persons are entitled to make a claim to the children's legal share and all of those so entitled have made such a claim, the amount payable by way of the children's legal share to each of them shall be ascertained—

- (a) if all the claimants are in the same degree of relationship to the deceased, by dividing the amount referred to in subsection (2) above among them equally; and
- (b) in any other case, by dividing the amount so referred to equally into a number of portions equal to the aggregate number of—
 - (i) the nearest surviving relatives, that is to say those persons who are nearest in degree of relationship to the deceased; and
 - (ii) the nearest predeceasing relatives, that is to say any other persons who were related to the deceased in that degree and who (if they had survived him) would have had a right to the children's legal share;and, of those portions, one shall be taken by each of the nearest surviving relatives, and one shall be taken in accordance with subsection (4) below by the surviving issue of each of the nearest predeceasing relatives, being issue who have a right as aforesaid.

(4) Where the issue of a nearest predeceasing relative consist of two or more persons, the portion to which they are entitled shall be shared between or among them as follows—

- (a) the portion shall be divided equally into a number of parts equal to the aggregate number of—
 - (i) any children of that relative who survive the deceased; and
 - (ii) any children of that relative who have failed to survive the deceased leaving issue who survive him;and of those parts, one shall be taken by each of the surviving children (if any), and one shall be taken in accordance with paragraph (b) below by the surviving issue of each predeceasing child (if any);
- (b) if the surviving issue of a predeceasing child referred to in paragraph (a) above consist of two or more persons, paragraph (a) above shall, subject to any necessary modification, have effect for the purpose of determining the amount of the part to be taken by each of those persons; and
- (c) the amount to be taken by way of the children's legal share out of the deceased's net estate by surviving issue of descendants of the deceased of remoter generations who predecease the deceased shall be determined in like manner.

EXPLANATORY NOTES

Clause 7

Subsection (1)

This subsection, implementing Recommendation 8(a), sets out the method for calculating the amount of a spouse's legal share. Unlike legal rights, the amount of legal share claimable by a surviving spouse is the same whether or not the deceased is also survived by issue.

Subsection (2)

This subsection sets out the method for calculating the amount of the children's legal share. Clause 5(3) provides that the issue have no claim out of the first £100,000 (or such other sum as may be prescribed) of estate to which the spouse succeeds as fiar. It implements Recommendation 8(b) and (c).

Subsections (3) & (4)

These subsections apportion the total sum representing the children's legal share amongst the deceased's children (or surviving issue representing predeceasing children) who claim. It follows the existing law on representation in legitim (Succession (Scotland) Act 1964, section 11(2)), but the rules of division are set out rather than by reference to division "*per stirpes*".

(5) Where two or more persons are entitled to make a claim to the children's legal share but any of them—

- (a) has renounced his entitlement to make a claim;
- (b) has failed to make a claim; or
- (c) having made a claim has withdrawn it,

the amount payable to any other claimant shall be unaffected thereby.

(6) Subject to section 11 of this Act, the amount payable by way of the spouse's legal share or the children's legal share to a claimant shall include interest thereon as from the date of the deceased's death until payment at the annual rate of 7% or such other rate as may be prescribed.

Effect of claim on other rights of succession.

8.—(1) Subject to subsection (2) below, a claimant shall, unless he withdraws his claim before payment, be deemed, for the purposes of any rights of succession to the deceased's estate of the claimant or any other person, to have failed to survive the deceased; and accordingly the claimant shall forfeit all rights of succession to the deceased's estate.

(2) Notwithstanding that a claimant has been deemed to have failed to survive the deceased under subsection (1) above, no property of the deceased shall, by virtue of that deemed failure, vest in—

- (a) issue of that claimant under—
 - (i) section 2(2) of this Act;
 - (ii) section 17 of this Act;
- (b) any person (including issue of that claimant) under a provision in the deceased's will in favour of that person which is conditional on the claimant failing to survive the deceased.

(3) Where, but for subsection (2) above, property of the deceased would have vested in issue of a claimant under section 2(2) of this Act, that issue shall be deemed, for the purposes of any rights of any other person to succeed to that property on intestacy, to have failed to survive the deceased.

(4) The foregoing provisions of this section are without prejudice to any provision made by the deceased which is inconsistent herewith.

(5) The effect of withdrawal of a claim before payment shall be to make the rights of succession of the claimant or any other person to the deceased's estate the same as they would have been if the claim had not been made.

(6) In this section "rights of succession" does not include rights arising on a claim being made under this Part of this Act.

EXPLANATORY NOTES

Subsection (5)

This subsection provides that the amount of legal share due by one of many potential claimants is unaffected by any renunciation or failure to claim by the others. It implements Recommendation 10(b). Under the existing law a renunciation of legal rights while the person from whose estate they will be claimable is still alive enlarges the share due to others. A post-death renunciation has no such effect.

For the purposes of this subsection a person is treated as entitled to make a claim even though his or her right to claim has been renounced.

Subsection (6)

Under the existing law, the rate of interest on legal rights is not fixed, but depends on what the estate as a whole earns. This subsection implements Recommendation 8(d) by providing for a statutory rate of roughly half the legal rate due on decrees for payment of money. The statutory rate may be varied by the Secretary of State.

Clause 8

Subsection (1)

This subsection sets out the effect of a claim for legal share; the claimant is deemed to have failed to survive the deceased. It implements Recommendations 14(a), (b) and (d). The deemed failure applies for the purposes of rights of succession to the deceased's estate of the claimant and all other beneficiaries. Rights of succession are defined in Clause 36(3) but a claim for legal share is excluded by Clause 8(5). Where the deceased and the claimant owned property which in terms of the title would have passed to the survivor of them, the deemed failure of the claimant to survive means that he or she does not inherit the deceased's share. But the deemed failure does not mean that the claimant's own share passes to the deceased's estate because the claimant is not deemed to have failed to survive for the purposes of succession to his or her own share of the property.

Subsection (2)

The purpose of this subsection is to prevent a person claiming legal share and passing on the forfeited rights of succession to his or her own family. It implements Recommendation 14(c).

Paragraph (a)(i) deals with intestacy. If the forfeited rights fall into intestacy or were part of the intestate estate the claimant's issue cannot claim them on the basis that the claimant failed to survive the deceased. The relatives next in line succeed (see subsection (3)).

Paragraph (a)(ii) prevents the surviving issue of a beneficiary who fails to survive the deceased from taking by virtue of Clause 17 the testamentary provision the beneficiary would have taken had he or she survived the deceased.

Paragraph (b) prevents a person who would, in terms of the deceased's will, take a testamentary provision in place of the claimant if the latter failed to survive the deceased from taking by virtue of the claimant's deemed failure to survive.

Subsection (3)

This subsection ensures that the deceased's next nearest relatives succeed to any intestate estate forfeited by a legal share claimant under subsection (1), and from which the claimant's issue are disqualified under subsection (2)(a)(i).

Subsection (5)

Because of the time limits in Clause 6 a claim for legal share may have to be submitted without full knowledge of the extent of the deceased's estate. This subsection allows a claimant to withdraw his or her claim for legal share without penalty.

Subsection (6)

Rights of succession which are forfeited under subsection (1) exclude legal share. Otherwise a legal share claimant could never make a valid claim as he or she would be deemed to have failed to survive the deceased.

Incidence of spouse's and children's legal shares.

9.—(1) The amount due by way of the spouse's legal share and the children's legal share shall be deducted from the following categories of the net estate of the deceased in the order in which they are mentioned—

- (a) net intestate estate;
- (b) residue;
- (c) general legacies;
- (d) special legacies.

(2) Where—

- (a) the net estate of the deceased falling within any category referred to in paragraphs (a) to (d) of subsection (1) above is more than sufficient to satisfy the claims to the spouse's legal share and the children's legal share so far as not already satisfied; and
- (b) there is more than one person entitled to property comprised in that category otherwise than by virtue of such a claim,

the amount payable by way of the spouse's legal share and the children's legal share out of that property shall be in proportion to the value of the property.

(3) Subsection (1) above is without prejudice to any provision made by the deceased which is inconsistent therewith.

Liability of claimant for administration expenses.

10.—(1) The rules as to the liability of a claimant to meet the expenses of administration of the deceased's estate shall be as follows—

- (a) if there is sufficient net intestate estate and residue to meet the expenses, the claimant shall be exempt therefrom;
- (b) if—
 - (i) the net estate includes neither net intestate estate nor residue; or
 - (ii) the net intestate estate and residue are insufficient to meet all the expenses,

the claimant shall be liable along with any general legatees, proportionately according to the value of the claim and any general legacies, for the expenses or the part of the expenses which cannot be met out of net intestate estate and residue.

(2) In this section references to net intestate estate, residue or general legacies shall be construed respectively as references to net intestate estate, residue or general legacies after taking account of—

- (a) any forfeiture of rights of succession under section 8(1) of this Act; and
- (b) any deduction made therefrom under section 9(1) of this Act.

EXPLANATORY NOTES

Clause 9

Subsections (1) & (3)

These subsections lay down (in the absence of any contrary directions by the testator) the order in which a claim for legal share is met from the various parts of the estate. They, together with Clause 5(3), implement Recommendations 12(a),(b) and (d).

Special legacies include property passing under a special destination or in terms of a statutory nomination (Clause 36(1)).

Subsection (2)

This subsection implements Recommendation 12(c). Within each category each beneficiary bears a part of the legal share claim proportional to the net value of his or her interest.

Clause 10

At present legal rights are calculated on the net estate after deduction of the expenses of administration of the deceased's estate up to and including obtaining confirmation, so that a claimant bears a proportionate share of such expenses. Clause 7, however, bases the amount due to a legal share claimant on the net estate. Net estate is defined in Clause 36(1) as the estate less debts and funeral expenses. This clause, implementing Recommendation 63(c), provides that as far as a legal share claimant is concerned the whole expenses of administration should first be taken out of any intestate estate or residue. General legatees together with the claimant become liable next, each bearing a share in proportion to the value of their legacies or claim.

Payment by instalments out of agricultural property.

11.—(1) This section applies where—

- (a) a claim has been made under this Part of this Act to the spouse's legal share or the children's legal share out of the deceased's estate and that estate includes agricultural property; and
- (b) any amount of the claim falls to be paid out of the agricultural property by virtue of section 9(1) of this Act.

(2) Subject to subsection (5) below, where this section applies the deceased's executor may pay the amount of the claim payable out of the agricultural property by not more than ten equal annual instalments.

(3) Interest at the relevant rate shall be payable on each such instalment as from the date when the instalment becomes due until the instalment is paid.

(4) For the purposes of subsection (3) above, the first such instalment shall be treated as becoming due on the date of the deceased's death and each subsequent instalment on the anniversary of the date when the immediately preceding instalment became due.

(5) If at any time there is a sale of—

- (a) the agricultural property and there is an unpaid balance of the amount of the claim payable out of that property; or
- (b) part or parts of that property and the sum realised from the sale or sales is at least as large as any such unpaid balance as at the date of sale or, if there is more than one sale, the date of the last sale,

that balance and interest at the relevant rate shall become payable by the deceased's executor to the claimant forthwith.

(6) In subsection (5) above "interest" means interest which has accrued on any unpaid instalment together with any interest on the unpaid balance as from the date when the balance becomes payable until the date of payment.

(7) In this section—

- (a) "agricultural property" means agricultural land or pasture and includes—
 - (i) woodland and any building used in connection with the intensive rearing of livestock or fish if the woodland or building is occupied with agricultural land or pasture and the occupation is ancillary to that of the agricultural land or pasture;
 - (ii) land used for the breeding and rearing of horses, and for the grazing of horses in connection with their breeding and rearing; and
 - (iii) such cottages, farm buildings (including buildings used in connection with the breeding and rearing of horses) and farmhouses, together with the land occupied by them, as are of a character appropriate to the property;
- (b) "the relevant rate" means 7% per annum or such other rate as may be prescribed.

EXPLANATORY NOTES

Clause 11

General

The purpose of this clause is to enable a claim for legal share to be met by the executors of a deceased farmer or landed estate owner without the farm or estate having to be sold or split up. It implements Recommendation 13.

Subsections (1) & (2)

The executors may elect to pay the proportion of the amount of legal share due out of the deceased's agricultural property (calculated according to Clause 9) by instalments over a period not exceeding 10 years. The remaining portion due out of other property is payable in a lump sum.

The entitlement to pay by instalments applies only where the deceased directly owned the agricultural property. If the deceased was a partner in a partnership or a shareholder in a company which owned the property the legal share is due in a lump sum.

Subsection (3)

Interest is due on each instalment only from the date on which it becomes payable to the date when it is paid. Where non-agricultural property is involved the legal share bears interest at 7% from the date of death until payment, see Clause 7(6).

Subsection (5)

The outstanding balance of the legal share payable out of the agricultural property becomes payable in a lump sum once the amount received by a sale or part sales equals the balance due at the date of the sale or last sale.

PART III

TESTAMENTARY DOCUMENTS

Validation of documents not executed or imperfectly executed.

12.—(1) Where a document has not been executed or has been imperfectly executed but the court, on an application being made to it, is satisfied that the document was intended by a person (since deceased) to take effect as his will or as a revocation, in whole or in part, of his will, it shall make an order declaring that the document was intended by that person to take effect as aforesaid.

(2) The effect of an order under subsection (1) above shall be that the document shall have effect as if it were formally valid and properly attested.

(3) If—

- (a) a document in respect of which the court is making an order under subsection (1) above is undated; or
- (b) there is uncertainty as to the place where such a document was executed or made,

but the court, on an application being made to it, is satisfied as to the date when or as to the period within which it was executed or made or as to that place, it shall in that order declare that date, period or place.

(4) Where an alteration to a document has not been executed or has been imperfectly executed but the court, on an application being made to it, is satisfied that the alteration was intended by a person (since deceased) to take effect as an alteration to his will or to a revocation, in whole or in part, of his will, it shall make an order declaring that the alteration was intended to take effect as aforesaid.

(5) Subsections (2) and (3) above shall apply to an alteration to a document as they apply to a document except that for any reference to a document or to an order under subsection (1) above there shall be substituted respectively a reference to an alteration to a document or to an order under subsection (4) above.

(6) An application under this section may be made either as separate proceedings or as incidental to and in the course of other proceedings; and for the purposes of this section the court shall be entitled to have regard to evidence (whether written or oral) extrinsic to the document.

(7) It shall be competent to register an order under subsection (1) or (4) above in the Books of Council and Session or in sheriff court books if the document to which the order relates—

- (a) is already so registered; or
- (b) where not already so registered, is so registered at the same time as the order;

but the order and the document shall be so registrable only in the same register.

EXPLANATORY NOTES

Clause 12

General

This clause empowers the court to declare an imperfectly authenticated testamentary document or even an unauthenticated document (or unauthenticated alterations) to be effective. It implements Recommendation 15.

Subsection (1)

In order for a declaratory order to be made the court must be satisfied (on the civil standard of proof) that the document is a document of the deceased, and that he or she intended it to take effect as a will or a revocation of a prior will. This subsection implements Recommendation 15(a) in part.

Will includes a testamentary trust disposition and settlement, a codicil, a statutory nomination or any other document of a testamentary nature. (Clause 36(1)).

Subsection (2)

This subsection implements Recommendation 15(b). A declaratory order enables the document to be registered in the Books of Council and Session or used for confirmation of the executors named in the document without further procedure. The order would also be effective in other countries if the formal validity of the document is, according to the rules of private international law, determinable by Scots law.

Subsection (3)

This subsection implements Recommendation 15(c). It empowers the court, in the same proceedings, to date a document validated under subsection (1) or to state where it was made.

Subsection (4)

This subsection extends the power of the court under subsection (1) to improperly authenticated or unauthenticated alterations. It implements Recommendation 15(a) in part.

Subsection (6)

This subsection implements Recommendation 15(d) and the remainder of Recommendation 15(a). Other proceedings include proceedings in the sheriff court for confirmation of an executor.

Subsection (7)

This subsection implements Recommendation 15(f).

- (8) In this section “the court” means in the case of an application made—
- (a) as separate proceedings—
 - (i) the Court of Session; or
 - (ii) the sheriff in whose jurisdiction the deceased was domiciled when he died or, if the deceased was domiciled in Scotland when he died but not in a particular part of it or it is unknown in which part he was so domiciled, the sheriff at Edinburgh;
 - (b) in the course of other proceedings, the court before which those proceedings are pending.

Rectification of wills.

13.—(1) Where a court is satisfied, on an application being made to it after the death of the testator, that a will prepared by a person other than the testator is so expressed that it fails to carry out his instructions, it may order the will to be rectified in any manner that it may specify in order to give effect to those instructions.

(2) An application under this section shall not, unless the court on cause shown allows it, be made after the end of the period of 6 months beginning with the date on which confirmation is granted in respect of the estate.

(3) For the purposes of subsection (1) above, the court shall be entitled to have regard to evidence (whether written or oral) extrinsic to the will.

1964 c.41.

(4) Subject to subsection (5) below and section 17 of the Succession (Scotland) Act 1964, a will ordered to be rectified under this section shall have effect as if it had always been so rectified.

(5) Where a will is rectified under this section, a trustee or executor shall not be personally liable for distributing in good faith any estate vested in him in accordance with the will as unrectified.

(6) Subsection (7) of section 12 of this Act shall apply for the purposes of this section as it applies for the purposes of that section.

- (7) In this section “the court” means—
- (a) the Court of Session; or
 - (b) the sheriff—
 - (i) in whose jurisdiction the testator was domiciled when he died; or
 - (ii) if the testator was domiciled in Scotland when he died but not in a particular part of it or it is unknown in which part he was so domiciled, the sheriff at Edinburgh.

EXPLANATORY NOTES

Clause 13

General

This clause extends the remedy of rectification, introduced for documents other than testamentary writings by sections 8 and 9 of the Law Reform (Miscellaneous Provisions) (Scotland) Act 1980, to testamentary writings. It implements Recommendation 16.

Subsection (1)

Judicial rectification is available only for a will prepared by a solicitor or other person for the testator. In order for rectification to be possible instructions must exist which it can be shown that the person preparing the will failed to implement.

Subsection (4)

Rectification is retrospective. Beneficiaries under the unrectified will who do not benefit under the will as rectified become under a legal obligation to restore the subject matter of their bequests (or their value) to the executors. Where a beneficiary has sold property conveyed to him or her by the deceased's executor under the provisions of the unrectified will subsequent rectification will not prejudice the title of a good faith purchaser. Section 17 of the Succession (Scotland) Act 1964 as amended by paragraph 11 of Schedule 1 to the Bill, protects such a purchaser.

Subsection (6)

This subsection extends the rules relating to the registration of documents and validating court orders in the Books of Council and Session or sheriff court books (see Clause 12(7)) to the registration of wills and rectification orders.

Effect of divorce or annulment of marriage on wills and special destinations.

14.—(1) Where a person by a will—

- (a) confers a benefit or power of appointment on his spouse; or
- (b) appoints his spouse as a trustee, executor, curator or tutor,

and the marriage is subsequently terminated by divorce or annulment, then, for the purposes of the operation of that will, that former spouse shall, unless the will indicates that the former spouse is to benefit or to be appointed as aforesaid under the will notwithstanding divorce or annulment, be deemed to have failed to survive that person.

(2) Subsection (1) above applies to a person who at the time of the execution of the will is not the spouse of the testator but who subsequently marries the testator as it applies to the testator's spouse, and references in that subsection to former spouse shall be construed accordingly.

(3) Where property is held in the name of—

- (a) spouses to a marriage and the survivor of them;
- (b) spouses to a marriage and another person and the survivor or survivors of them;
- (c) one spouse with a special destination, on that spouse's death, in favour of the other spouse,

and the marriage is subsequently terminated by divorce or annulment, then, on the death of one of the former spouses or (in a case to which paragraph (c) above applies) of the spouse in whose name the property is held, unless the destination indicates that the surviving former spouse is to take thereunder notwithstanding divorce or annulment, the surviving former spouse shall, in relation to the succession to the deceased's property or part thereof under the destination, be deemed to have failed to survive the deceased.

(4) Where any person has in good faith and for value, whether by purchase or otherwise, acquired title to property or to any interest in property, the title so acquired shall not be challengeable on the ground that the property falls to the estate of a deceased former spouse by virtue of subsection (2) above.

1979 c.33.

(5) At the end of section 12(3) of the Land Registration (Scotland) Act 1979 (exclusion of indemnity) there shall be added the following paragraph—

“(q) the loss is suffered by the estate of a deceased former spouse in respect of property falling to it where the title to the property or to any interest in the property has been acquired by another person and is unchallengeable by virtue of section 14(4) of the Succession (Scotland) Act 1990.”

(6) In this section “divorce or annulment” means divorce or annulment which is—

- (a) granted by a court of civil jurisdiction in any part of the British Islands; or
- (b) obtained in a country outwith the British Islands and recognised in Scotland under Part II of the Family Law Act 1986.

1986 c.55.

EXPLANATORY NOTES

Clause 14

Subsection (1)

This subsection partially implements Recommendations 17(a) and (b). The effect on a will of the testator's subsequent divorce (or annulment of the marriage) is that provisions in favour of the former spouse are revoked, unless the will indicates that the former spouse is to remain a beneficiary notwithstanding the divorce or annulment. Examples of types of provisions revoked are legacies, or benefits under a testamentary trust. The ex-spouse's appointment as an executor or trustee or as a curator or tutor to the children of the marriage, is also terminated as is a power of appointment in respect of a particular fund. The revocation is implemented by deeming the surviving former spouse to have failed to survive the deceased testator. This deemed failure to survive is effective not only for the provisions in favour of the former spouse, but also for all other provisions of the will, such as a gift to a charity in the event of the spouse's failure to survive.

Will includes a statutory nomination (see Clause 36(1)). Special destinations are dealt with in subsection (3).

Subsection (2)

This subsection makes it clear that a provision in favour of someone, such as a cohabitee or fiancé(e), whom the testator subsequently marries is also revoked by a later divorce or annulment.

Subsection (3)

This subsection implements the remainder of Recommendations 17(a) and (b).

Paragraphs (a) and (b) concern property subject to a survivorship destination involving the former spouses. The effect of the deemed failure of the former spouse to survive the deceased is that the deceased's share of the property becomes part of the deceased's estate, rather than passing to the former spouse. The deemed failure to survive applies only for the purposes of the succession to the deceased's share, so that the former spouse who actually survives the deceased retains his or her own share of the property.

Paragraph (c) deals with destinations of the type "to one spouse (A) whom failing the other (B)." They are much less common than survivorship destinations. The effect of a subsequent divorce or annulment is that if A dies first the property becomes part of A's estate and does not pass to B. If B dies first the destination flies off and A thereafter possesses the property on an absolute title.

Subsection (4)

This subsection protects a person who acquires for value in good faith from the surviving former spouse property which the spouses held on a destination. It implements Recommendation 17(d). In the case of a survivorship destination, an acquirer without knowledge of the divorce will believe that he or she has acquired the full property. In fact only the surviving former spouse's share has been acquired, since the other former spouse's estate owns the other share. "Interest in property" includes the interest of heritable creditors and extends the protection to them.

Subsection (5)

This subsection implements Recommendation 17(e). Where a good faith acquirer's title to the whole property has been registered in the Land Register the Keeper is prevented under section 9 of the Land Registration (Scotland) Act 1979 from rectifying the register to show that only part of the property was acquired. But for this subsection, the Keeper would be obliged to indemnify the deceased former spouse's estate in respect of the share belonging to the estate which the surviving former spouse has sold. The loss falls in the first place on the estate, but the estate will generally have a right of recovery at common law against the surviving former spouse.

Subsection (6)

This subsection implements Recommendation 17(c).

Abolition of rule that subsequent birth of child may revoke will.

15. The rule of law known as the *conditio si testator sine liberis decesserit* (in accordance with which a will may in certain circumstances be held to be revoked by the birth of a child to the testator after the execution of the will) shall cease to have effect.

Revival of revoked wills.

16.—(1) Where a will has been expressly revoked in whole or in part, the will or the revoked part thereof shall not be revived unless—

- (a) the will is subsequently re-executed; or
 - (b) another document which expressly revives the will or the revoked part is executed or validated by an order under section 12(1) of this Act.
- (2) Any rule of law which is inconsistent with this section shall cease to have effect.

Beneficiary predeceasing leaving issue.

17.—(1) Where a person named in a will as a beneficiary (“the beneficiary”) is a direct descendant of the testator and does not survive the date of vesting of the bequest, the bequest shall, unless the will clearly intends otherwise, be taken by any issue of the beneficiary who survive the date of vesting.

(2) For the purposes of subsection (1) above, the will shall in particular be regarded as having clearly intended otherwise if the will provides (expressly or by implication) that the bequest is made to—

- (a) the beneficiary and another person or persons, and the survivor or survivors of them; or
- (b) the beneficiary whom failing another person or persons.

(3) Where under a will a bequest is to be shared by more than one direct descendant, the share of the bequest which issue of a beneficiary take by virtue of subsection (1) above shall be the share which the beneficiary would have taken if he had survived the date of vesting of the bequest, having regard to whether or not any other direct descendant, or issue of such a descendant, has survived that date.

(4) Where under this section two or more persons, as issue of a beneficiary, are entitled among them to the bequest, or to a part thereof, the bequest or, as the case may be, that part, shall—

- (a) if all those persons are in the same degree of relationship to the beneficiary, be divided among them equally; and
- (b) in any other case, be divided equally into a number of portions equal to the aggregate number of—
 - (i) the nearest surviving relatives, that is to say those persons who are nearest in degree of relationship to the beneficiary; and
 - (ii) the nearest predeceasing relatives, that is to say any other persons who were related to the beneficiary in that degree, but who have died before the date of vesting of the bequest leaving issue who survive until that date;

and of those portions, one shall be taken by each of the nearest surviving relatives, and one shall be taken in accordance with subsection (5) below by the surviving issue of each of the nearest predeceasing relatives.

EXPLANATORY NOTES

Clause 15

This clause implements Recommendation 18. The *conditio* is seldom invoked in current practice. It is usually more advantageous for a child born after the date of a parent's will which makes no provision for the child to let the will stand and claim legal rights, rather than have the will revoked and the parent very probably die intestate. A child not provided for under the deceased's will would be entitled under Clauses 5 to 11 to claim legal share.

Clause 16

This clause implements Recommendation 20. Express revocation occurs by a clause to that effect in a subsequent document. Implied revocation by a subsequent will with different provisions is not within the scope of this clause.

The rule of law referred to in subsection (2) provides that the revocation of a will which in turn contains a clause revoking a prior will results in certain circumstances in the revival of the prior will.

Clause 17

General

This clause restates with considerable modification the common law rule *conditio si institutus sine liberis decesserit*. This entitles issue of a predeceasing beneficiary in certain circumstances to take the legacy the beneficiary would have taken had he or she survived the testator (or the date of vesting). It implements Recommendation 19.

Subsection (1)

This subsection implements Recommendations 19(a) and (b). The *conditio* can apply to nephews and nieces, but the new statutory provision is limited to bequests to direct descendants of the testator. The subsection applies to bequests in wills and other testamentary writings, but not to benefits conferred by *inter vivos* documents.

The will may exclude the operation of this subsection by words showing a clear intention to do so.

The date of vesting will normally be the date of the testator's death, but may be later if vesting is postponed.

Subsection (2)

Reversing the present law, this subsection provides that a survivorship or whom failing clause will exclude the issue of a predeceasing beneficiary. It implements Recommendation 19(c).

Subsection (3)

This subsection implements Recommendation 19(d). Under the present law the issue of a predeceasing beneficiary take only the share the beneficiary would have taken had he or she survived the testator (or the date of vesting) and all other beneficiaries had so survived. Subsection (3) allows the issue to benefit from any accretion due to the failure of other beneficiaries to survive without leaving any issue.

Subsections (4) and (5)

These subsections restate the existing law and set out how the bequest due to the issue of a predeceasing beneficiary is to be divided amongst them.

(5) Where the issue of a nearest predeceasing relative consist of two or more persons, the portion to which they are entitled shall be shared between or among them as follows—

- (a) the portion shall be divided equally into a number of parts equal to the aggregate number of—
 - (i) any children of that relative who survive the beneficiary; and
 - (ii) any children of that relative who have failed to survive the beneficiary leaving issue who survive him;and of those parts, one shall be taken by each of the surviving children (if any), and one shall be taken in accordance with paragraph (b) below by the surviving issue of each predeceasing child (if any);
- (b) if the surviving issue of a predeceasing child referred to in paragraph (a) above consist of two or more persons, paragraph (a) above shall, subject to any necessary modification, have effect for the purpose of determining the amount of the part to be taken by each of those persons; and
- (c) the amount of the bequest to be taken by surviving issue of descendants of the deceased of remoter generations who predecease the deceased shall be determined in like manner.

(6) This section shall not apply if the beneficiary under the will died before the date of execution of the will.

(7) The rule of law known as the *conditio si institutus sine liberis decesserit* (in accordance with which certain relatives of a deceased person may in certain circumstances become entitled to the rights under a deed to which the deceased person would have become entitled if he had not died) shall cease to have effect.

Vesting of fee on termination of liferent.

18.—(1) Where—

- (a) a liferent of any property has been granted to a person and the fee of that property to another person; and
- (b) the liferenter forfeits, renounces or ceases to be entitled to the liferent otherwise than by virtue of his death,

then the fee shall, unless the document expressly provides otherwise, vest in the fiar on the date on which it would have vested in him if the liferenter had died on the date when he forfeited, renounced or ceased to be entitled to the liferent.

EXPLANATORY NOTES

Subsection (6)

This subsection continues the present law.

Subsection (7)

Because of the number and substantial nature of the reforms recommended, the *conditio* is expressly abolished and the new rules stated in statutory form, rather than having many statutory amendments to the common law rule.

Clause 18 This clause implements Recommendation 59.

A liferent may terminate (for example, as a result of a renunciation) earlier than the death of the liferenter, but the fee may not vest then due to the failure of the document creating the liferent and fee to deal with the unexpected termination. In addition the Bill provides for forfeiture of a liferent in three new situations; Clause 8 (liferenter claiming legal share), Clause 14 (liferenter's marriage to testator dissolved by divorce or annulment after date of will) and Clause 19 (liferenter having unlawfully killed testator or truster).

In order to prevent the problems which arise with unvested fees this clause provides that so far as the vesting of the fee is concerned the liferenter is deemed to have died on the date of the termination or forfeiture, unless the document expressly provides otherwise.

The clause applies to liferents created by *inter vivos* or testamentary documents.

PART IV

FORFEITURE OF KILLER'S RIGHTS OF SUCCESSION

Forfeiture and effect of forfeiture.

19.—(1) Where a person has been convicted—

(a) by a court in the British Islands or a court-martial of murder, culpable homicide or manslaughter; or

(b) by a court outwith the British Islands of a crime which if it had been committed in Scotland would have amounted to murder or culpable homicide,

and the conviction is no longer appealable nor subject to an appeal, he shall, subject to section 20 of this Act, forfeit—

(i) any rights of succession to the estate of the person whom he has killed (“the victim”);

(ii) any beneficial interest in property which (but for this subsection) he would have acquired in consequence of the death of the victim, being property which, before the death, was held in trust for any person;

(iii) any property acquired by him by virtue of a donation *mortis causa* made by the victim.

(2) A person who has incurred forfeiture under subsection (1) above or under the forfeiture rule shall be deemed to have failed to survive the victim—

(a) for the purposes of any rights of succession to the estate of the victim, or

(b) in relation to any beneficial interest or property mentioned in subsection (1)(ii) or (iii) above.

(3) Where any person has in good faith and for value, whether by purchase or otherwise, acquired title to property or to any interest in property, the title so acquired shall not be challengeable on the ground that it was acquired directly or indirectly from a person who in relation to that property has incurred forfeiture under subsection (1) above or under the forfeiture rule.

1979 c.33.

(4) At the end of section 12(3) of the Land Registration (Scotland) Act 1979 (exclusion of indemnity) there shall be added the following paragraph—

“(r) the loss arises by reason of forfeiture of—

(i) rights of succession in respect of property, or

(ii) a beneficial interest in property,

under subsection (1) of section 19 of the Succession (Scotland) Act 1990 or under the forfeiture rule (as defined in that section) and the title to the property is unchallengeable by virtue of subsection (3) of that section.”.

(5) For the purposes of the distribution of the victim's estate or any trust property, the executor, trustee or any other person shall be entitled to rely on a duly authenticated extract or copy of any conviction referred to in subsection (1) above.

(6) If the court, on an application being made to it, is satisfied that a person has failed to execute any document which may be necessary to give effect to a forfeiture under subsection (1) above or under the forfeiture rule, it may authorise a clerk of court to do so; and the execution of a document by a clerk of court under this subsection shall have the like force and effect in all respects as if the document had been executed by that person.

EXPLANATORY NOTES

Clause 19

General

This clause sets out new statutory provisions on unlawful killing in the context of succession. The new provisions continue to follow the approach of the existing common law in general, but areas of uncertainty and doubt are clarified.

Subsection (1)

This subsection implements Recommendation 34(a). Forfeiture is an automatic result of a final conviction for the crimes specified in paragraphs (a) or (b). The killer may however apply for relief under Clause 20.

British Islands means the United Kingdom, the Channel Islands and the Isle of Man, Interpretation Act 1978, Schedule 1.

Rights of succession mentioned in paragraph (i) are defined in Clause 36(3). They comprise rights under the deceased's will, on intestacy, to property passing by virtue of a special destination, and to claim legal share out of the deceased's estate.

Paragraph (ii) deals with an interest in property held in a trust created by the victim during his or her lifetime or by another person which would pass to the unlawful killer on the death of the victim.

Subsection (2)

This subsection makes it clear what is to happen to the rights of succession and other rights mentioned in subsection (1) forfeited by the killer. The reference to the forfeiture rule makes it clear that a conviction is not essential for forfeiture. It implements Recommendations 34(b) (in part) and 35.

The deemed predecease of the killer is only for the purposes of succession to the deceased victim's estate. Where the victim and the killer held property on a title containing a survivorship destination the killer retains his or her own share of the property, but the deceased victim's share remains in the victim's estate.

Subsection (3)

This subsection protects the title of a good faith acquirer whose title would otherwise be affected by the killer's forfeiture. It implements Recommendation 37(a). "Interest in property" includes the interest of a heritable creditor.

Subsection (4)

This subsection implements Recommendation 37(b). Where a good faith acquirer's title to property (acquired directly or indirectly from the killer) has been registered in the Land Register for Scotland the Keeper is prevented under section 9 of the Land Registration (Scotland) Act 1979 from rectifying the register to give effect to the killer's subsequent forfeiture. But for this subsection, the Keeper would be obliged to indemnify the deceased's estate (or trustees) because of their failure to recover the property from the acquirer. The loss falls on the estate (or the trust) but the executors (or trustees) will generally have a right of recovery at common law against the killer.

Subsection (6)

When forfeiture occurs after property from the deceased's estate has been distributed those in possession of the property (other than good faith acquirers who are protected under subsection (3)) will be under a duty to hand it back if they are no longer entitled to it. This subsection provides for the situation where a person under that duty refuses to sign the necessary documents. It implements Recommendation 36. The application may be made to the Court of Session or the sheriff court.

Succession (Scotland) Bill

(7) In this section and section 20 of this Act—

“the court” means—

- (a) the Court of Session; or
- (b) the sheriff of the sheriffdom in which the victim was domiciled at the date of his death or, if that domicile is uncertain or at that date the victim was domiciled outwith Scotland, the sheriff at Edinburgh;

“court-martial” has the same meaning as in section 57(1) of the Courts-Martial (Appeals) Act 1968;

“the forfeiture rule” means the rule of law which in certain circumstances precludes a person who has unlawfully killed another from acquiring a benefit in consequence of the killing.

1968 c.20.

Relief from forfeiture except in case of murder conviction.

20.—(1) Subject to the provisions of this section, where a person has forfeited—

- (a) under section 19(1) of this Act; or
- (b) under the forfeiture rule,

rights of succession, any beneficial interest in property or property acquired by virtue of a donation *mortis causa*, the court, on an application being made to it, may, if it seems reasonable to do so having regard to all the circumstances of the case, make an order revoking the forfeiture in whole or in part, and may make any other order that the court may consider necessary or proper for giving full effect to the revocation.

(2) An application under subsection (1) above in respect of a forfeiture under section 19(1) of this Act shall be required to be made within 6 months after the conviction concerned ceases to be appealable or subject to appeal.

(3) It shall be incompetent to make an order under subsection (1) above, if the forfeiture concerned arose by virtue of a conviction of murder by a court in the British Islands or a court-martial.

EXPLANATORY NOTES

Clause 20

General

This clause continues the policy of the Forfeiture Act 1982 (Section 2 of which is repealed for Scotland, see Schedule 2 to the Bill) by empowering the court, on application, to grant relief against forfeiture arising out of an unlawful killing.

Subsection (1)

This subsection implements Recommendations 38(a) (in part) and (c). The power to grant relief is discretionary in cases of culpable homicide or analogous crimes. Relief may be total or partial depending on the circumstances. The application may be made to the Court of Session or the sheriff court.

Subsection (2)

This subsection extends the period within which an application may be made for relief from forfeiture resulting from a conviction from 3 months to 6 months after the conviction becomes final. It implements Recommendation 38(b). There is no time limit in the absence of a conviction.

Subsection (3)

This subsection implements Recommendation 38(a) in part. As under the present law, relief is not available where the forfeiture arises out of a conviction for murder by a court in the British Islands or a court-martial. British Islands means the United Kingdom, Channel Islands or Isle of Man. (Interpretation Act 1978, Schedule 1.)

Relief may be available where the murder conviction was by a foreign court. It would be up to the Scottish civil court hearing the application for relief to decide in the knowledge of what the crime consisted of and the procedure employed to obtain the conviction, whether relief should be granted, bearing in mind that a conviction for murder by a court in the British Islands would bar relief.

PART V

ADMINISTRATION OF ESTATES

Confirmation to be competent where no estate in Scotland.
1964 c.41.

21. After section 14 of the Succession (Scotland) Act 1964 there shall be inserted the following section—

“Confirmation to be competent where no estate in Scotland”.

14A. It shall be competent for an executor to be confirmed in respect of the estate of a person who was domiciled in Scotland when he died, notwithstanding that none of that estate is situated in Scotland.”.

Provisions relating to leases.
1964 c.41.

22. Section 16 of the Succession (Scotland) Act 1964 shall have effect subject to the following modifications—

(a) in subsection (2) for the words from “to any one” to “the estate” there shall be substituted the word “at the value settled under subsection (2C) below to any one of the persons who is entitled to succeed to the deceased’s net intestate estate or who has made a claim under Part II of the Succession (Scotland) Act 1990 to the spouse’s legal share or the children’s legal share out of his net estate”;

(b) after subsection (2) there shall be inserted the following subsections—

“(2A) Notwithstanding any rule of law, the persons to whom the executor shall be entitled to transfer the interest under subsection (2) above shall include himself as an individual.

(2B) An executor who is intending to transfer the interest to any person under subsection (2) above shall—

(a) determine the value for which he intends to transfer the interest; and

(b) intimate that intention and the value so determined to any other person (reasonably discoverable by the executor) who is entitled to succeed to the deceased’s net intestate estate or who has made a claim under Part II of the said Act of 1990 to the spouse’s legal share or the children’s legal share out of his net estate.

(2C) For the purposes of subsection (2) above, the value of the interest shall be the value determined by the executor under paragraph (a) of subsection (2B) above:

Provided that if the transferee or any of the persons to whom intimation has been made under paragraph (b) of that subsection does not agree with the value so determined, the value of the interest shall be such value as may be agreed between the transferee and all those persons or, failing such agreement, such value (as at the date of first intimation under the said paragraph (b)) as may be determined—

(a) in the case of an interest under an agricultural lease, by the Land Court; or

(b) in any other case, by the Lands Tribunal for Scotland.

(2D) Where the value (as settled under subsection (2C) above) of the interest transferred in pursuance of subsection (2) above is greater than the value of the transferee’s share of the deceased’s estate so far as not already satisfied, the transferee shall be liable to the estate for a sum representing the difference between those values.”.

EXPLANATORY NOTES

Clause 21

At present confirmation is incompetent if none of the deceased's estate is situated in Scotland. This clause implements Recommendation 47. It empowers the Scottish courts to confirm an executor where the deceased died domiciled in Scotland, but left no estate there.

Clause 22

General

Section 16 of the Succession (Scotland) Act 1964 empowers the executor of a tenant to dispose of the deceased's interest under a lease notwithstanding any prohibition of bequests or assignments contained in the lease. This clause makes several changes to the procedure.

Paragraph (a)

Unless the deceased tenant's interest in the lease has been validly bequeathed (in which case no transfer order under section 16 is necessary), the interest is intestate estate. The executor may, at present, transfer the interest to any person entitled to prior rights, legal rights or a share of the free estate. This paragraph makes modifications consequential on the abolition of prior rights and the replacement of legal rights by legal share in Parts I and II of the Bill respectively.

Paragraph (b)

An executor is prohibited under the common law from transferring the interest in the lease to himself or herself as an individual. This rule was held to apply to transfers under section 16 of the Succession (Scotland) Act 1964 (*Inglis v Inglis* 1983 SLT 437). Subsection (2A), implementing Recommendation 50(b), disappplies the prohibition from such transfers.

Subsections (2B) and (2C) provide a procedure for determining the value of the interest to be transferred. They implement Recommendation 50(a). If the executor, transferee and all those whose shares in the estate would be affected by the value are unable to agree a value it is to be determined by the Scottish Land Court (in the case of agricultural leases) or by the Lands Tribunal for Scotland (for other leases). Section 16(9) of the Succession (Scotland) Act 1964 defines an agricultural lease as including a lease of a smallholding or croft.

Subsection (2D) removes a doubt in the present law. It implements Recommendation 51 and provides that if the value of the interest transferred exceeds the value of the transferee's share of the estate, he or she must pay the difference to the estate.

Surviving spouse's
right to acquire
matrimonial
home and
contents.

23.—(1) Subject to the following provisions of this section, where a person dies leaving a spouse, the surviving spouse shall have a right to acquire the interest of the deceased in the matrimonial home and (whether or not that right is exercised) its contents in satisfaction in whole or in part of the spouse's rights of succession to the deceased's estate.

(2) The surviving spouse shall have a right under subsection (1) above only if the home or (as the case may be) its contents are—

(a) intestate estate to the whole or part of which the surviving spouse is entitled;
or

(b) the residue or part of the residue of the deceased's estate and the surviving spouse is the residuary beneficiary or one of the residuary beneficiaries.

(3) Where the value of the interest sought to be acquired by a surviving spouse under this section exceeds the value of the spouse's rights of succession so far as not already satisfied, the spouse shall have a right to acquire that interest by paying to the deceased's estate a sum equal to the difference between those values.

(4) Where the deceased had an interest in more than one matrimonial home, the surviving spouse shall have a right to acquire the interest under this section only in relation to such one of them as the surviving spouse may elect:

Provided that this subsection shall not prevent the spouse from acquiring the deceased's interest in one matrimonial home (but not the contents) and his interest in the contents of another matrimonial home.

(5) A surviving spouse shall not be precluded from acquiring an interest of the deceased under this section by reason that the spouse is an executor of the deceased.

(6) A surviving spouse shall not have a right to acquire an interest under this section unless, not later than 6 months after confirmation of an executor in respect of the deceased's estate, the spouse gives written intimation of an intention to acquire the interest—

(a) to the executor or, if the spouse is one of the executors, to the other executors;
or

(b) if the spouse is the sole executor, to any residuary legatee (reasonably discoverable by the spouse), any person who has made a claim under Part II of this Act to the children's legal share out of the deceased's net estate and, if the matrimonial home or contents were intestate estate, to any other person (reasonably discoverable by the spouse) who is entitled to succeed to the deceased's net intestate estate.

(7) A surviving spouse shall not have a right to acquire an interest under this section unless the matrimonial home concerned or (as the case may be) its contents remain part of the deceased's estate at the date when the spouse gives intimation under subsection (6) above.

EXPLANATORY NOTES

Clause 23

General

This clause gives the surviving spouse an entitlement to acquire from the estate the deceased's interest in the matrimonial home and furnishings in satisfaction of his or her share in the estate. The option arises where the deceased died intestate or where the interest in the matrimonial home is part of the residue of the estate to which the spouse is entitled, either alone or with others. It implements Recommendations 40 and 41.

Subsection (1)

This subsection implements Recommendation 40(a) in part. The right to acquire contents is independent of any right to acquire a matrimonial home. "Matrimonial home" and "contents" are defined in subsections (9) and (10) respectively and "rights of succession" in subsection (11).

Subsection (2)

This subsection sets out the two situations where the spouse's entitlement to acquire arises.

Subsection (3)

This subsection implements the remainder of Recommendation 40(a). It makes it clear that where the value of the deceased's interest in the matrimonial home or contents exceeds the value of the spouse's share of the estate, the spouse may still acquire but must pay the difference to the estate.

Subsection (4)

This subsection deals with the unusual case where the deceased possessed two or more matrimonial homes. It implements Recommendation 40(d). The spouse has the right to choose which (if any) he or she wishes to acquire. The right to acquire contents is exercisable independently of the right to acquire the home. Thus the spouse could acquire house A and the contents of house B.

Subsection (5)

This subsection prevents the acquisition being reducible on the ground that the spouse was both an executor and the acquirer. It implements Recommendation 41(e).

Subsection (6)

This subsection lays down a time limit within which the spouse must intimate the intention to acquire and specifies the persons to whom intimation is to be given. It implements Recommendations 41(a) and (b). The notice will probably also state the value at which the spouse proposes to acquire the items. Where the spouse is not an executor or the sole executor the spouse intimates to the executor or other executor. The executor will in turn intimate the spouse's intention to acquire to the persons mentioned in paragraph (b) because they have to agree the value of the items sought to be acquired. Where the spouse is the sole executor he or she notifies the persons directly.

Subsection (7)

This subsection makes it clear that the spouse may only acquire items which have not already been disposed of by the executors. It would be prudent for executors not to dispose of items which the spouse is entitled to acquire without ascertaining his or her intentions.

(8) For the purpose of the acquisition of an interest by a surviving spouse under this section and the calculation of the value of the rights of succession of the spouse or any other person to the deceased's estate, the value of that interest shall be—

- (a) such value as may be agreed by the spouse, the executor and all of the persons referred to in subsection (6)(b) above; or
- (b) failing such agreement, its open market value (at the time when the spouse intimated under subsection (6) above an intention to acquire it) as determined by an arbiter—
 - (i) appointed by the parties; or
 - (ii) failing agreement by the parties, appointed by the sheriff principal of the sheriffdom in which the deceased was domiciled at the date of his death or, if that domicile is uncertain or at that date the deceased was domiciled outwith Scotland, by the sheriff principal of the Lothians and Borders.

1981 c.59.

(9) In this section "matrimonial home" has the same meaning as in the Matrimonial Homes (Family Protection)(Scotland) Act 1981 but it does not include a home—

- (a) which forms part only of the subjects of a lease under which the deceased was the tenant; or
- (b) which was used by the deceased for carrying on a trade, profession or occupation, if the value of the estate as a whole would be likely to be substantially diminished if the home were disposed of otherwise than with the assets of the trade, profession or occupation.

(10) In this section the "contents" of a matrimonial home mean furniture, articles of household use, ornaments, consumable stores, garden effects and domestic animals but do not include any article used by the deceased for business purposes, money, any motor vehicle or caravan or any heirloom; and for the purposes of this definition "heirloom", in relation to the deceased's estate, means any article which has associations with the deceased's family of such nature and extent that it ought to pass to some member of that family other than the surviving spouse of the deceased.

(11) In this section any reference to the rights of succession of any person to the deceased's estate shall be construed as a reference to rights of that person to property of the deceased arising—

- (a) under the deceased's will otherwise than by virtue of a nomination in accordance with the provisions of any enactment;
- (b) on the deceased's intestacy; or
- (c) on a claim being made to the children's legal share under Part II of this Act.

Valuation of estate.

24. For the purposes of this Act, the value of the net estate or net intestate estate of a deceased person shall, subject to section 23(8) of this Act, be its value at the date of his death, but the value—

- (a) of any such estate which is realised in ordinary course and without undue delay after the death of the person, except in so far as such estate is capable of an accurate valuation as at the date of that death, shall be determined by reference to the value as realised; and
- (b) of an interest transferred under subsection (2) of section 16 of the Succession (Scotland) Act 1964 shall be determined in accordance with subsection (2C) of that section.

1964 c.41.

EXPLANATORY NOTES

Subsection (8)

This subsection implements Recommendations 41(c) and (d). The value has to be agreed by all those involved, failing which it is fixed by arbitration. On arbitration the value will be the open market value of the deceased's interest in the item at the date of the spouse's intimation of intention to acquire. The value fixed will affect not only the spouse's share of the estate but also the share of other beneficiaries or legal share claimants.

Subsection (9)

Paragraphs (a) and (b) implement Recommendation 40(c) and continue the present exceptions from the surviving spouse's prior rights to the home under section 8(2) of the Succession (Scotland) Act 1964.

Subsection (10)

The spouse is not entitled to acquire heirlooms (see Recommendation 40(e)). Heirlooms are currently excluded from the spouse's prior rights under section 8 of the Succession (Scotland) Act 1964.

Clause 24

This clause by and large restates the existing law as developed in modern cases. It implements Recommendation 64. The acquisition of the home or contents by the surviving spouse (Clause 23(8)), and the transfer of the deceased's interest as tenant under a lease (section 16 of the Succession (Scotland) Act 1964 referred to in paragraph (b)), have their own rules relating to valuation.

Succession (Scotland) Bill

Abolition of
mournings.

25. Any rule of law which entitles the widow and family of a deceased person to an allowance out of his estate to meet the expense of mournings shall cease to have effect; and any reference to funeral expenses in any enactment shall be construed as excluding the expense of mournings.

Abolition of rule
enabling payment
of temporary
aliment out of
deceased's estate.

26. Any rule of law relating to the payment of temporary aliment out of a deceased's estate shall cease to have effect.

Aliment payable
by deceased not
to be payable by
executor or
successor.

27. Any rule of law whereby a person who is owed an obligation of aliment may claim aliment from the executor of a deceased person or from any person enriched by the succession to the estate of a deceased person shall cease to have effect.

EXPLANATORY NOTES

Clause 25

This clause abolishes the entitlement of the widow and family to special mourning clothes at the expense of the estate. It implements Recommendation 54.

Clause 26

Temporary aliment is the entitlement of a surviving spouse and issue of the deceased to be maintained out of the estate for up to six months after the death. This clause abolishes temporary aliment, so implementing Recommendation 56. Executors could make payments to account of the payee's share of the estate in cases of hardship.

Clause 27

This clause abolishes the obsolescent remedy of aliment *ex jure representationis* claimable by a surviving spouse or children from the deceased's estate. It implements Recommendation 55. The remedy of a spouse or child left without provision is to claim legal share under Clauses 5 to 11 of the Bill.

PART VI
SURVIVORSHIP

Survivorship.

28.—(1) Subject to subsection (2) below, rights of succession of a person to the estate of a deceased shall not vest in him unless he survives the deceased for a period of at least 5 days commencing with the beginning of the day on which the deceased died.

(2) It shall be competent for a testator to state (either expressly or by clear implication) that a provision under the will in favour of a person—

(a) shall vest in that person if he survives for such shorter period; or

(b) shall not vest in him unless he survives for such longer period,

than the period mentioned in subsection (1) above as the testator shall specify in that or any other will.

(3) Where a person has failed to survive the deceased for the period required by subsection (1) or (as the case may be) subsection (2) above for him to be entitled to any property of the deceased, he shall be regarded, in relation to any rights of succession of any other person to that property, as having predeceased the deceased.

(4) Where two or more persons have died in circumstances rendering it uncertain which (if any) survived the other or others for any period which is relevant for the disposition of any estate of either or any of them, then, unless the contrary intention appears in the document regulating the disposition, that estate shall be disposed of as if the other or others had failed to survive him for that period.

(5) Where property is to be transferred to one of two or more persons according to their order of death and does not form part of the estate of either or any of those persons before his death, then, if there is uncertainty as to the order of death of those persons, the property or its value shall, unless the contrary intention appears in the document regulating the obligation to transfer, be divided equally between or among their estates.

(6) Any reference in a will to a person—

(a) surviving or failing to survive shall be construed in accordance with subsection (1) or (2) above;

(b) predeceasing shall be construed as a reference to a person failing to survive within the meaning of subsection (1) or (2) above.

(7) Any reference in a special destination to a person—

(a) surviving or failing to survive shall be construed in accordance with subsection (1) above;

(b) predeceasing shall be construed as a reference to a person failing to survive within the meaning of subsection (1) above.

(8) For the purposes of a donation *mortis causa*, the donee shall be regarded as having failed to survive the donor unless he survives him for a period of at least 5 days commencing with the beginning of the day on which the donor died.

EXPLANATORY NOTES

Clause 28

Subsection (1)

This subsection lays down the general rule that a person has to survive the deceased for at least 5 days in order to succeed. It implements Recommendations 21(a), (b), and (d). At present mere survivance is sufficient unless the will provides otherwise. Rights of succession are defined in Clause 36(3) as rights to testamentary provisions, on intestacy, by way of legal share or under a special destination or nomination.

Subsection (2)

This subsection enables a testator to provide for either a longer or shorter period of survivance than the statutory 5 day period in subsection (1). It implements Recommendation 21(c). The vesting of a testamentary provision is postponed until the period of survivance required has elapsed.

Subsection (3)

The effect of a beneficiary failing to survive for the required period is that he or she is deemed to have predeceased the deceased, so implementing the rest of Recommendation 21. This deemed predecease applies for all purposes of succession to the deceased's estate. Thus for example, a legacy to A whom failing B will be taken by B if A fails to survive for the required period. However, the deemed predecease will not affect the survivor's own share of property held with the deceased on a survivorship destination. This is because the devolution of the survivor's own share is not a matter of succession to the deceased's estate.

Subsection (4)

This subsection deals with the situation where it is not possible to decide whether the beneficiary survived the deceased testator for the required period and the will or other document does not provide for the situation. It replaces the rules contained in section 31 of the Succession (Scotland) Act 1964 (repealed by Schedule 2 to the Bill) and implements Recommendation 22.

The onus is on a beneficiary or his or her estate to establish that he or she survived for the required period. In the absence of satisfactory evidence of survival the provisions in favour of the beneficiary will go to those who would succeed had the beneficiary failed to survive the deceased.

Subsection (5)

This subsection implements Recommendation 23. If it is impossible to establish the order of death of two or more persons property destined according to the order of death to one of them is divided equally among their estates. Examples of property to which the subsection might apply include a life interest to two people with the fee to the survivor of them, or a life assurance policy on the joint lives of a married couple payable to the estate of the first person to die. The document regulating the devolution of the property may of course provide for a different rule of division and this will override the statutory equal division rule.

Subsection (6)

The new rules on survivance in subsections (1) to (5) apply to all post-commencement deaths in terms of Recommendation 24. This subsection defines the terms "surviving", "failing to survive" or "predeceasing" in the wills of persons dying after commencement, whatever the date of the will, (see Clause 34).

Subsection (7)

It is not possible to alter the period required to survive in a special destination. Survivor therefore means a person who survives for at least 5 days under subsection (1), and cognate terms are construed similarly.

Subsection (8)

This subsection implements Recommendation 58(b). If the donee fails to survive the donor for at least 5 days he or she is deemed to have predeceased. Under the existing common law the predecease of the donee results in the donation lapsing. This will apply to a deemed predecease.

PART VII
DESTINATIONS

Destinations.

29.—(1) A special destination in a title to property contained in a document in favour of two or more persons and the survivor or survivors of them shall continue to be effective but, subject as aforesaid, any such destination (however expressed) in favour of—

- (a) a person whom failing another person; or
- (b) two or more persons and the survivor or survivors of them and, on the death of the survivor or survivors, another person,

shall be ineffective in so far as it is in favour of the other person referred to in paragraph (a) or (b) above.

(2) Nothing in subsection (1) above shall affect the operation of—

- (a) section 26 of the Titles to Land Consolidation (Scotland) Act 1868 or section 45 of the Conveyancing (Scotland) Act 1874; or
- (b) a destination of property in favour of a person whom failing another person, if under the destination each of those persons is to hold the property as a trustee.

(3) Where property is held in the name of two or more persons, and the survivor or survivors of them, each of those persons may, notwithstanding any agreement or undertaking to the contrary and whether or not both, or more than one of them, have contributed to the acquisition of the property, dispose (whether or not for value) of his share in the property during his lifetime or by will:

Provided that this subsection is without prejudice to any claim for damages for breach of any such agreement or undertaking as aforesaid.

(4) In subsections (1), (2) and (3) above “property” does not include the interest of a tenant under a lease or an assignation of a lease if the interest cannot be assigned without the consent of the landlord.

(5) Where in a will, or in a trust taking effect during the lifetime of the truster, there is a destination (however expressed) of property, whether heritable or moveable, in favour of one person, whom failing another person, then, if and as soon as the property vests in the first person mentioned above, the other person shall lose all right to that property; and any rule of law which is inconsistent with this subsection shall cease to have effect.

(6) A person who succeeds to property by virtue of a special destination on the death of the deceased shall be liable for any debts of the deceased to the extent that they do not exceed the value of that property as at the date of the deceased’s death:

Provided that, where such a person has paid any debts which do not fall to be paid out of the property passing under the special destination, he shall be entitled to reimbursement therefor out of the deceased’s estate.

(7) Where a lease or an assignation of a lease (in a case where the interest of the tenant is assignable without the consent of the landlord) contains a special destination in favour of two or more persons and the survivor or survivors of them, then, on the sequestration of the estate of any of those persons or on the interest of any of them being adjudged, the destination in favour of the survivor or survivors, in so far as it relates to the interest in the lease of the person whose estate has been sequestrated or whose interest has been adjudged, shall cease to have effect.

(8) A will executed on or after 10th September 1964 shall not have effect so as to evacuate a special destination (being a destination which could competently be evacuated by the will) unless it contains a specific reference to the destination and a declared intention on the part of the testator to evacuate it.

1868 c.101.
1874 c.94.

EXPLANATORY NOTES

Clause 29

Subsection (1)

This subsection, implementing Recommendations 25(a) and 25(b) in part, renders ineffective all special destinations except survivorship destinations in documents. Where the destination is ineffective the property devolves on the death of the original owner according to his or her will or the rules of intestacy rather than in terms of the destination.

A destination to one person in liferent and another in fee is not struck at by subsection (1) because each person has from the outset a separate interest in the property and the liferenter's interest does not devolve on his or her death to the fiar.

Subsection (2)

This subsection makes it clear that destinations to office holders, owners of estates etc, and their successors or to nominated individuals in succession as trustees remain competent. It implements Recommendation 25(b) in part.

Subsection (3)

This subsection implements Recommendation 30(a). In survivorship destinations each co-owner will have the capacity in all circumstances to evacuate the destination so far as his or her own share is concerned. Subsection (8) lays down what form of words in a will is required for an effective evacuation.

Subsection (4)

In non-freely assignable leases special destinations and express or implied prohibitions on evacuation are to remain competent, because of the continuing interest of the third party landlord. This subsection implements Recommendations 31 and 32. Most leases prohibit assignation either absolutely or without prior consent of the landlord.

Subsection (5)

This subsection implements Recommendation 26. At present the effect of a provision "to A whom failing B" depends on the nature of the property involved. If the provision involves heritable property B succeeds on A's death unless A disposed of the property in another way. If the provision involves moveable property or a mixture of heritable and moveable property B has no rights once A succeeds. The effect of the subsection is that once A succeeds, B will have no rights under such a provision whatever the nature of the property involved.

Subsection (6)

This subsection implements Recommendation 29. It removes the doubt created by the decision in *Barclays Bank Ltd v McGreish* 1983 SLT 344. Under this subsection the successor becomes personally liable for the deceased's debts up to the value of the property received. This liability can be enforced by diligence against any assets of the successor once it has been constituted by a court decree. Liability can be avoided by renouncing the succession. Although the liability extends to the whole of the deceased's debts (up to the value of the property received), the successor may have a right of relief against the executors if under the rules of incidence of debts, part or all of the debts are due to be borne by other parts of the deceased's estate.

Subsection (7)

This subsection applies the rule for destinations in non-leasehold property to similar destinations in leasehold property where the interest of the tenant is freely assignable. It implements Recommendation 33. Where the landlord is required to consent to any assignation any destination in the lease or assignation will continue to be effective against the tenant's trustee in sequestration or an adjudger of the tenant's interest.

Subsection (8)

This subsection re-enacts section 30 of the Succession (Scotland) Act 1964 (repealed by Schedule 2 to the Bill) in order to have all the provisions relating to special destinations in one enactment.

PART VIII

MISCELLANEOUS AND GENERAL

Right of tenant to bequeath interest under lease.

1886 c.29.
1949 c.75.
1955 c.21.

Challenge of acts on deathbed.

Private international law.

Construction of existing documents.

30.—(1) A bequest by a tenant of his interest under a tenancy or lease to any one of the persons who, if the tenant had died intestate, would be, or would in any circumstances have been, entitled to succeed to his net intestate estate by virtue of Part I of this Act shall not be treated as invalid by reason only that there is among the conditions of the tenancy or lease an implied condition prohibiting assignation.

(2) This section shall not prejudice the operation of section 16 of the Crofters Holdings (Scotland) Act 1886 or section 20 of the Agricultural Holdings (Scotland) Act 1949 (which relate to bequests in the case of agricultural leases) or of section 10 of the Crofters (Scotland) Act 1955 (which makes similar provision in relation to crofts).

31. Nothing done by a person shall be liable to challenge or reduction on the ground that it was done on his deathbed.

32.—(1) The capacity of a person to make or revoke a will (whether in relation to heritable or moveable property) shall be determined in accordance with the domestic law of the country where the person was domiciled at the time when he made or, as the case may be, revoked the will.

(2) The construction of a document (other than a will) in so far as it regulates the beneficial interest in moveable property forming part of a deceased's estate shall, unless the document provides otherwise, be determined in accordance with the domestic law of the country where the deceased was domiciled immediately before his death.

(3) Subject to the foregoing provisions of this section, nothing in this Act shall be construed as affecting the operation of any rule of law applicable immediately before the commencement of this Act to the choice of the system of law governing the administration, winding up or distribution of the estate, or any part of the estate, of any deceased person.

33. In relation to the estate of a deceased person, any reference in any provision of a document executed before the commencement of this Act to legal rights (however expressed) in relation to the law of succession, shall be construed as a reference to an entitlement to make a claim to the spouse's legal share or the children's legal share (as the case may be) out of the deceased person's net estate under Part II of this Act.

EXPLANATORY NOTES

Clause 30

This clause re-enacts section 29 of the Succession (Scotland) Act 1964 (repealed by Schedule 2 to the Bill) in order to leave in that Act only the provisions relating to administration of estates. Section 29 is of limited practical use because most formal leases expressly exclude an assignation or bequest.

The enactments mentioned in subsection (2) contain provisions for bequests by tenants of their interests under agricultural or crofting leases, objections to the bequest by landlords and the judicial resolution of such objections.

Clause 31

This clause makes it clear that it is not competent to challenge a transaction by a deceased person which was not effected by a document on the ground that it was done during the deceased's last illness. It implements Recommendation 57.

Clause 32

Subsection (1)

This subsection applies the Scottish rules of capacity to make or revoke a will involving moveable property to wills involving heritable property. It implements Recommendation 67.

Subsection (2)

This subsection overrules *Connell's Trs v Connell's Trs* (1886) 13R 1175 in which it was held that the destination in a title to shares in English companies acquired by a domiciled Scot were to be construed according to English law. It implements Recommendation 68. Scottish rules of construction are to be applied to the title where the property is moveable and the deceased owner is domiciled in Scotland at death. Where two co-owners have different domiciles each of their shares will devolve according to the law of their respective domiciles. For heritable property the document of title will continue to be construed according to the law of the country in which the property is situated.

Subsection (3)

All the other rules of private international law relating to succession and administration of estates are preserved. Changes may occur if the United Kingdom ratifies the Hague Convention on the Law Applicable to Succession to the Estates of Deceased Persons signed at the Hague in October 1988.

Clause 33

This clause replaces any reference to legal rights (*jus relictæ*, *jus relictî*, legitim, terce and courtesy) in documents executed before the coming into force of legislation implementing the recommendations in the report by a reference to the legal share claimable by the deceased's spouse or issue under Clauses 5 to 11 of the Bill, where the deceased dies after the coming into force. It implements Recommendation 66.

Transitional provisions.

34.—(1) The provisions of this Act (except this subsection) shall not apply in relation to the estate of a person who has died before the commencement of this Act.

(2) For the purposes of this Act, if it is uncertain whether a person died before or after the commencement of this Act, he shall be deemed to have died after such commencement.

(3) Section 17 of this Act shall not apply in relation to a document executed before the commencement of this Act.

(4) Section 29(1) to (5) of this Act shall not apply in relation to—

(a) a document executed before the commencement of this Act, or

(b) a special destination in a title to property contained in a document implementing a provision in such a document as is mentioned in paragraph (a) above.

(5) Section 32(1) of this Act shall not apply in relation to a will, or to a document revoking a will, executed before the commencement of this Act.

Regulations.

35.—(1) Any power to make regulations conferred on the Secretary of State by any provision of this Act shall be exercisable by statutory instrument.

(2) Regulations under this Act shall be subject to annulment in pursuance of a resolution of either House of Parliament.

EXPLANATORY NOTES

Clause 34

Subsection (1)

This subsection implements Recommendation 65(a). It provides that the changes made by the Bill will only affect the distribution of estates of people who die after the date of the coming into force of legislation implementing the recommendations in the report (“commencement”).

Subsection (2)

This subsection implements Recommendation 65(b).

Subsections (3) to (5)

General

These subsections set out the exceptions to the general rule that the Bill’s provisions apply to wills and other documents whether executed before or after commencement.

Subsection (3)

This subsection implements Recommendation 65(e). Clause 17 makes new provision for the issue of a predeceasing beneficiary to take his or her bequest in certain circumstances, and replaces existing common law rules. Pre-commencement wills will have been prepared against the background of a very different set of rules.

Subsection (4)

This subsection implements Recommendations 25(b), 26, 30(b), 31, 32 and 65(e). Clause 29(1)-(5) renders ineffective certain special destinations in titles to property and destinations—over of the type “to A whom failing B” in wills, and confers on the owners of property subject to destinations freedom to evacuate them. Rights under existing documents would be adversely affected by applying these changes retrospectively.

Subsection (5)

This subsection implements in part Recommendation 67. Clause 32(1) provides that capacity to make or revoke a will relating to heritable property will depend on the law of the testator’s domicile, instead of the law of the country where the property is situated. Confining this change to post-commencement wills avoids retrospectively annulling or validating existing wills.

Clause 35

This clause sets out how the Secretary of State’s power to make regulations is to be exercised. Regulations under the Bill are concerned with:—

Clause 1(2)—prescribing sum other than £100,000 to which surviving spouse entitled on intestacy.

Clause 5(3)—prescribing sum other than £100,000 to which spouse succeeds out of which issue cannot claim legal share.

Clause 7(1) and (2)—prescribing sum other than £200,000 for purposes of higher rate band for legal share claim.

Clause 7(5)—prescribing rate of interest due on legal share claim.

Clause 11(7)—prescribing rate of interest due on unpaid instalments of legal share payable out of agricultural property.

Interpretation and
exclusion from
operation of Act.

36. (1) In this Act—

“enactment” includes an enactment contained in a subordinate instrument;

“estate” means, subject to section 32(3) of this Act, the whole estate of whatever kind belonging to the deceased at the time of his death;

“lease” and “tenancy” include sub-lease and sub-tenancy, and tenant shall be construed accordingly;

“net estate”, in relation to a deceased person, means his estate less—

(a) the debts (other than inheritance tax) for which his estate is liable as at the date of death; and

(b) any funeral expenses;

“net intestate estate” means any net estate which is not disposed of by will or under a special destination;

“prescribed” means prescribed by regulations made by the Secretary of State;

“special destination” means a provision in a title to particular property (whether heritable or moveable) which directs the devolution of the property on a person’s death to a person who is named or otherwise specified or to a class of person, but does not include a provision which directs the devolution of property to heirs of the deceased who are neither named nor otherwise specified;

“special legacies” includes property passing under a special destination on the death of the deceased or by virtue of a nomination of the deceased in accordance with the provisions of any enactment;

“surviving spouse” does not include a person whose marriage to the deceased was terminated by divorce or annulment—

(a) granted by a court of civil jurisdiction in any part of the British Islands; or

(b) obtained in a country outwith the British Islands and recognised in Scotland under Part II of the Family Law Act 1986;

“will” includes a testamentary trust disposition and settlement, a codicil, a nomination of a deceased in accordance with the provisions of any enactment, or any other document of a testamentary nature.

(2) Except in section 28 of this Act, any reference in this Act to a person surviving, or failing to survive, another person shall be construed in accordance with subsection (1) or (as the case may be) subsection (2) of that section.

(3) Subject to sections 8(6) and 23(11) of this Act, any reference in this Act to the rights of succession to the estate of a deceased person shall be construed as a reference to rights to property arising—

(a) under the deceased’s will;

(b) on the deceased’s intestacy;

(c) on a claim being made under Part II of this Act; or

(d) under a special destination.

(4) Nothing in this Act shall apply to any title, coat of arms, honour or dignity transmissible on the death of the holder thereof or affect the succession thereto or the devolution thereof.

(5) Nothing in the definition of net estate in subsection (1) above shall affect the operation of the Inheritance Tax Act 1984.

1986 c.55.

1984 c.51.

EXPLANATORY NOTES

Clause 36

Subsection (1)

This subsection defines certain terms used in the Bill.

- “estate” means both heritable and moveable estate but, because Clause 32(3) preserves the existing rules of private international law, immovable property situated in a country other than Scotland will not generally be included in estate governed by the Bill.
A donation *mortis causa*, like any other lifetime gift subject to revocation before death, does not form part of the deceased's estate.
- “net estate” This definition sets out the deductions that are made in order to arrive at net estate for the purposes of the Bill, including the division of the net intestate estate between spouse and issue (Clause 1(2)), and the calculation of spouse's and children's legal share (Clause 7). After these amounts have been calculated inheritance tax may be chargeable (see subsection (5)), and the expenses of administering the deceased's estate allocated. Clause 10 deals with the liability of a legal share claimant for administration expenses.

- “will” A special destination has testamentary effect but it is not a document of a testamentary nature.

Subsection (4)

These excluded items have their own special rules of devolution.

Subsection (5)

See note on “net estate” in subsection (1) above.

Succession (Scotland) Bill

Amendments and
repeals.

37.—(1) The enactments mentioned in Schedule 1 to this Act shall have effect subject to the amendments respectively specified in that Schedule, being minor amendments and amendments consequential on the provisions of this Act.

(2) The enactments set out in Schedule 2 to this Act are hereby repealed to the extent specified in the third column of that Schedule.

Short title,
commencement
and extent.

38.—(1) This Act may be cited as the Succession (Scotland) Act 1990.

(2) This Act shall come into force on such day as the Secretary of State may by order made by statutory instrument appoint.

(3) This Act extends to Scotland only.

EXPLANATORY NOTES

SCHEDULES

SCHEDULE 1

MINOR AND CONSEQUENTIAL AMENDMENTS

Section 37(1).

The Confirmation of Executors (Scotland) Act 1823 (c.98)

1. For section 2 there shall be substituted the following section—
- “Caution 2. Caution shall not be required to be found by—
- (a) an executor-nominate; or
 - (b) an intestate’s spouse who shall be an executor-dative and has right, by virtue of sections 8 and 9(2) of the Succession (Scotland) Act 1964 or Part I of the Succession (Scotland) Act 1990, to the whole estate,
- but in all other cases the person to whom confirmation is granted shall be required to find caution, the amount of which shall be a sum equal to the gross value of the estate to be administered by him.”.

The Confirmation of Executors (Scotland) Act 1858 (c.56)

2. For section 2 there shall be substituted the following section—
- “Appointment of executor dative. 2.—(1) A relative, donee or creditor of a deceased person shall be entitled to present a petition for appointment as executor-dative of the deceased.
- (2) Subject to subsection (3) below, for the purposes of this section, a relative of a deceased person is a person who would be entitled, by virtue of Part I of the Succession (Scotland) Act 1990, to succeed to any net intestate estate of the deceased or, if the sheriff is satisfied that no such person is to present a petition under this section, any relative of the deceased other than by virtue of marriage.
- (3) Where more than one relative has presented a petition in accordance with subsection (2) above, the sheriff shall, unless there is good reason not to do so, appoint as executor-dative one or more of those most nearly related to the deceased.”.

The Intestates Widows and Children (Scotland) Act 1875 (c.41)

3. In section 3 for the words “according to the practice of the commissary court” there shall be substituted the words “in accordance with section 2 of the Confirmation of Executors (Scotland) Act 1823”.

The Titles to Land Consolidation (Scotland) Act 1868 (c.101)

4. In section 20 after the words “and the executor of the grantor” there shall be inserted the words “, or the grantee or legatee of the lands,”.

The Judicial Factors (Scotland) Act 1889 (c.39)

5. At the end of section 11A there shall be added the following subsection—
- “(3) In subsection (1) above the persons having an interest in the succession of parties deceased include a person making a claim to the spouse’s legal share or the children’s legal share under Part II of the Succession (Scotland) Act 1990.”.

The Sheriff Courts (Scotland) Act 1907 (c.51)

6. In section 40 after the word “agents” there shall be inserted the words “(including the fees of agents in connection with proceedings in the commissary court)”.

EXPLANATORY NOTES

Schedule 1

General

This schedule contains minor amendments to various statutes and gives effect to the relocation of statutory provisions recommended in the report. It also makes amendments consequential on changes in the earlier parts of the Bill.

Paragraph 1

This paragraph continues the existing law whereby an executor-nominate or a spouse who succeeds to the deceased's whole intestate estate (by virtue of the Succession (Scotland) Act 1964 or Clause 1 of the Bill) is not required to find caution. This implements Recommendation 49.

Caution is to be found for the full gross value of the estate administered by the executor instead of the estate confirmed to, so implementing Recommendation 48.

Paragraph 2

This provision re-enacts section 2 with the modifications required to implement Recommendation 45. Donees—residuary beneficiaries—are usually confirmed as executors nominate under the Executors (Scotland) Act 1900, but a dative appointment has advantages in exceptional cases. Confirmation of creditors as executors-dative is a method of enforcing debts and is seldom used. In the vast majority of cases the person seeking appointment as executor dative will be a relative of a deceased intestate.

Normally the executor-dative will be the nearest relative of the deceased and will be entitled to at least a share of the intestate estate. The sheriff is empowered, however, to appoint non-beneficiary blood relatives if the beneficiaries do not apply for appointment. For example, they may not wish to act, may lack legal capacity or cannot be found.

Paragraph 3

This paragraph extends the changes made to the legislation for ordinary estates by Paragraph 2 to the legislation for small intestate estates.

Paragraph 4

This paragraph permits a legatee or general donee of heritable property to use the deceased's will as a link or warrant when deducing or completing title to the property. It implements Recommendation 44. This procedure will be an alternative to the use by an executor of a docket endorsed on the confirmation in terms of section 15 of the Succession (Scotland) Act 1964.

Paragraph 5

This paragraph makes it clear that a legal share claimant may apply to the court for a judicial factor to be appointed to administer the deceased's estate and deal with the claim if no executor is acting.

Paragraph 6

This provision is a consequence of repealing (by Schedule 2 to the Bill) section 22 of the Succession (Scotland) Act 1964 (which gives the Court of Session power to prescribe forms for appointment of executors) and re-enacting it minus the power to regulate fees in the Sheriff Courts (Scotland) Act 1971 (see Paragraph 17). The power to regulate fees is added to the existing power in the 1907 Act.

The Trusts (Scotland) Act 1921 (c.58)

7. After section 29 there shall be inserted the following section—

“Protection of trustees from liability for error in property distribution.

29A.—(1) Subject to subsection (2) below, a trustee shall not be personally liable for any error in the distribution of any property, or the income of any property, vested in him as trustee, if the error was caused by not knowing of the existence or non-existence of any person or his relationship or lack of relationship to another person.

(2) A trustee shall be exempt from personal liability under subsection (1) above only if—

(a) he has acted in good faith and has made such enquiries as a reasonable and prudent trustee would have made in the circumstances of the case; or

(b) he has made the distribution in accordance with an order of the court.

(3) Without prejudice to section 17 of the Succession (Scotland) Act 1964, nothing in the foregoing provisions of this section shall affect any right of any person entitled to the property concerned to recover the property, or any property representing it, from any person who may have received it.”

8. After section 33 there shall be inserted the following section—

“Executor dative to have powers of trustee.

33A. An executor dative appointed to administer the estate of a deceased person shall have in his administration of such estate the whole powers, privileges and immunities, and be subject to the same obligations, limitations and restrictions, which gratuitous trustees have, or are subject to, under any enactment or rule of law; and this Act and the Trusts (Scotland) Act 1961 shall have effect as if any reference therein to a trustee included a reference to such an executor dative:

Provided that nothing in this section shall exempt an executor dative from finding caution for his intromissions or confer upon him any power to resign or to assume new trustees.”

The Crofters (Scotland) Act 1955 (c.21)

9. In section 11—

(a) in subsection (1) for the words “that Act” there shall be substituted the words “the Succession (Scotland) Act 1964”;

(b) in subsection (4) at the end of paragraph (b) there shall be inserted the words “or

(c) to claim children’s legal share under Part II of the Succession (Scotland) Act 1990 out of that estate,”;

(c) in subsection (4A) after the word “spouse” there shall be inserted the words “or children’s legal share under Part II of the Succession (Scotland) Act 1990”.

The Succession (Scotland) Act 1964 (c.41)

10. In section 15(2) after paragraph (b) there shall be inserted the following paragraph—

“(bb) to any person entitled to a share in the estate by virtue of Part I or Part II of the Succession (Scotland) Act 1990; or”.

11. In section 17—

(a) for the words from “acquired title” to “as aforesaid” there shall be substituted the words “, whether by purchase or otherwise, acquired title to property or to any interest in property, which has vested in an executor on confirmation thereto,”;

EXPLANATORY NOTES

Paragraph 7

This paragraph generalises scattered enactments dealing with protecting trustees from lack of knowledge of relationship by blood or adoption of potential beneficiaries to the deceased. It implements Recommendation 42.

Paragraph 8

This paragraph relocates section 20 of the Succession (Scotland) Act 1964 (repealed by Schedule 2 to the Bill) dealing with the powers and duties of executors-dative. Section 20 is re-enacted in the Trusts (Scotland) Act 1921 which regulates the functions of trustees and executors.

Paragraph 11

This paragraph implements Recommendation 43. The amendments to section 17 extend the protection of persons deriving title to executry assets from the confirmed executor. First, moveable property is included, and secondly persons acquiring for value otherwise than by purchase are protected.

Succession (Scotland) Bill

(b) at the end there shall be added the following subsection—

“(2) In this section “property” means property of whatever kind.”.

Sch. 1

12. In section 18(2) for the words from “being” to “otherwise” there shall be substituted the words “where the circumstances are such at the date of that death that the destination takes effect”.

13. In section 36(1) after the definition of “owner” there shall be inserted the following definition—

“special destination” means a provision in a title to particular property (whether heritable or moveable) which directs the devolution of the property on a person’s death to a person who is named or otherwise specified or to a class of person, but does not include a provision which directs the devolution of property to heirs of the deceased who are neither named nor otherwise specified;”.

14. In section 36(2) for proviso (a) there shall be substituted the following proviso—

“(a) where—

(i) any heritable property belonging to a deceased person at the date of his death is subject to a special destination in favour of any person; and

(ii) the circumstances are such at that date that the destination takes effect,

that property shall not be treated for the purposes of this Act as part of the estate of the deceased; and”.

15. In Schedule 1 after paragraph (c) there shall be inserted the following paragraph—

“(cc) in [part] satisfaction of any share which he has in the said estate by virtue of Part I or Part II of the Succession (Scotland) Act 1990;”.

16. In Schedule 2, in paragraphs 1 and 2(a) for the words “this Act” there shall be substituted the words “the Succession (Scotland) Act 1990”.

The Sheriff Courts (Scotland) Act 1971 (c.58)

17. In section 32, after subsection (1) there shall be inserted the following subsection—

“(1A) The Court of Session may by act of sederunt regulate the procedure to be followed, and prescribe the form and content of any petition or other document to be used, in connection with the confirmation of executors; and such an act of sederunt shall include provision for the inclusion in the confirmation of an executor, by reference to an appended inventory or otherwise, of a description, in such form as may be so provided, of any heritable property forming part of the estate.”.

The Prescription and Limitation (Scotland) Act 1973 (c.52)

18. In Schedule 1, at the end of paragraph 2(f) there shall be added the words “or to the spouse’s legal share or the children’s legal share under Part II of the Succession (Scotland) Act 1990;”.

EXPLANATORY NOTES

Paragraphs 12 to 14

The changes in relation to special destinations are explained in paragraphs 6.10 to 6.14 of the report.

Paragraph 17

See notes on paragraph 6.

Paragraph 18

This paragraph extends the existing rules on prescription of legal rights to legal share which replace them.

The Adoption (Scotland) Act 1978 (c.28)

19. For section 39(5) there shall be substituted the following subsection—

“(5) This section is subject to section 39A of this Act.”.

20. After section 39 there shall be inserted the following section—

“Adopted person to be treated for purposes of succession etc as child of adopter.

39A.—(1) For all purposes relating to—

- (a) the succession to a deceased person (whether testate or intestate), and
- (b) the disposal of property by virtue of any *inter vivos* document,

an adopted person shall be treated as the child of the adopter and not as the child of any other person.

(2) In this section any reference to succession to a deceased person shall be construed as including a reference to the distribution of any property in consequence of the death of the deceased person and any claim to the spouse's legal share or the children's legal share out of his estate under Part II of the Succession (Scotland) Act 1990.

(3) Notwithstanding subsection (1) above, where—

- (a) the adopter of an adopted person has died; or
- (b) in relation to a person adopted jointly by spouses, both spouses have died,

before 10th September 1964, the adopted person shall be treated for the purposes of succession to the estate of a natural parent as the child of that parent.

(4) In any document whereby property is conveyed or under which a succession arises, being a document executed after the making of an adoption order, unless the contrary intention appears, any reference (whether express or implied)—

- (a) to the child or children, or issue, of the adopter shall be construed as, or as including, a reference to the adopted person;
- (b) to the child or children, or issue, of the adopted person's natural parents or either of them shall be construed as not being, or as not including, a reference to the adopted person; and
- (c) to a person related to the adopted person in any particular degree or way shall be construed as a reference to the person who would be related to him in that degree or way if he were the child of the adopter and were not the child of any other person:

Provided that for the purposes of this subsection a document containing a provision taking effect on the death of any person shall be deemed for the purposes of that provision to have been executed on the date of death of that person.

(5) Where the terms of any document provide that any property or interest in property shall devolve along with a title, honour or dignity, nothing in this section shall prevent that property or interest from so devolving.

(6) For the purposes of the law regulating the succession to any property and for the purposes of the construction of any such document as aforesaid, an adopted person shall be deemed to be related to any other person, being the child or the adopted child of the adopter or (in the case of a joint adoption) of either of the adopters—

EXPLANATORY NOTES

Paragraphs 19 and 20

These paragraphs re-enact with minor modifications the provisions relating to succession rights of adopted persons contained in sections 23 and 24 of the Succession (Scotland) Act 1964 and section 5 of the Law Reform (Miscellaneous Provisions) (Scotland) Act 1966 (all repealed by Schedule 2 to the Bill) and relocate them in the Adoption (Scotland) Act 1978. They implement Recommendations 52 and 53.

(a) where he or she was adopted by two spouses jointly and that other person is the child or adopted child of both of them, as a brother or sister of the whole blood;

(b) in any other case, as a brother or sister of the half blood.

(7) Nothing in the foregoing provisions of this section shall affect any document executed, or the devolution of any property on, or in consequence of, the death of a person who died, before the commencement of the Succession (Scotland) Act 1990.

(8) Where an adoption order is made in respect of a person who has been previously adopted, the previous adoption shall be disregarded for the purposes of this section in relation to the devolution of any property on the death of any person dying after the date of the subsequent adoption order, and in relation to any document executed after that date whereby property is conveyed or under which a succession arises.

(9) Nothing in this section shall apply to any title, coat of arms, honour or dignity transmissible on the death of the holder thereof or affect the succession thereto or the devolution thereof.”

The Capital Gains Tax Act 1979 (c.14)

21. In section 47—

(a) in subsection (2) after the words “partial intestacy” there shall be inserted the words “, or by virtue of a claim to the spouse’s legal share or the children’s legal share out of a deceased’s estate under Part II of the Succession (Scotland) Act 1990”;

(b) in subsection (3)—

(i) after the words “partial intestacy” there shall be inserted the words “or by virtue of such a claim as aforesaid”; and

(ii) at the end there shall be added the words “or in or towards satisfaction of the claim.”.

The Forfeiture Act 1982 (c.34)

22. In section 3—

(a) in subsection (1) after the word “rule” there shall be inserted the words “and forfeiture under section 19(1) of the Succession (Scotland) Act 1990”;

(b) in subsection (2)(b) for the words from “1976” to the end there shall be substituted the words “1976 and sections 13(4) and 16(1) of the Family Law (Scotland) Act 1985 (variation etc of periodical allowances and agreements relating thereto).”.

23. At the end of section 4 there shall be added the following subsection—

“(6) In this section any reference to the forfeiture rule shall include a reference to forfeiture under section 19(1) of the Succession (Scotland) Act 1990.”.

The Inheritance Tax Act 1984 (c.51)

24. At the end of section 17 there shall be added the following paragraph—

“(e) the renunciation of an entitlement, or the failure, to make a claim to the spouse’s legal share or the children’s legal share under Part II of the Succession (Scotland) Act 1990.”.

25. At the end of section 42 there shall be added the following subsection—

“(5) Where on the death of a person a claim is made under Part II of the Succession (Scotland) Act 1990 to the spouse’s legal share or the children’s legal share in the deceased’s estate by a person entitled to make such a claim, the amount payable by way of the legal share shall be treated for the purposes of this Chapter as a specific

EXPLANATORY NOTES

Paragraph 21

This paragraph makes it clear that an executor may transfer executry assets in satisfaction of a claim for legal share without liability for capital gains tax.

Paragraphs 22 and 23

These amendments are consequential upon the changes made to the law on forfeiture by Clauses 19 and 20.

Paragraph 24

A renunciation of the right to claim legal share or the failure to claim legal share is not to be regarded as a transfer of value. This paragraph implements Recommendation 60.

Paragraph 25

This paragraph extends the rules on legal rights to the new legal shares. It implements Recommendation 61. Legal share is to be calculated on the net estate before tax and the amount of the children's legal share will be treated, for the purposes stated, as a specific gift bearing its own tax.

Succession (Scotland) Bill

Sch. 1

gift which bears its own tax (if any); and, in determining that amount, any tax payable on the estate of the deceased shall be left out of account.”.

26. After section 147 there shall be inserted the following section—

“Scotland:
spouse’s and
children’s legal
share.

147A. Where on the death of a person a claim is made under Part II of the Succession (Scotland) Act 1990 to the spouse’s legal share or the children’s legal share in the deceased’s estate by a person entitled to make such a claim, this Act shall have effect as if the amount payable by way of the legal share had been left by the deceased to the claimant, and the amount to which any other person is entitled out of the deceased’s estate had been altered accordingly.”.

The Finance Act 1985 (c.54)

27. In section 84(7)—

- (a) after the word “satisfaction” there shall be inserted “(a)”;
- (b) after the word “legitim” there shall be inserted the words “or
(b) of a claim by a surviving spouse to the spouse’s legal share or by surviving issue to the children’s legal share under Part II of the Succession (Scotland) Act 1990,”.

EXPLANATORY NOTES

Paragraph 26

This paragraph implements Recommendation 62. The effect of a claim for legal share is that for inheritance tax purposes the estate is assessed as if the claimant had been left a legacy of the same amount as the claim with consequential readjustment in terms of Clauses 8 and 9 of the Bill to the amounts receivable by other beneficiaries.

Paragraph 27

This paragraph extends the existing exemption from stamp duty for an instrument apportioning executry assets to a legal rights claimant to a person claiming the new legal share.

ENACTMENTS REPEALED

| <i>Chapter</i> | <i>Short title</i> | <i>Extent of Repeals</i> |
|-------------------------|---|--|
| 1594 c.30 | The Parricide Act 1594 | The whole Act. |
| 4 Geo. 4 c.98 | The Confirmation of Executors (Scotland) Act 1823 | Section 1. |
| 21 & 22 Vict. c.56 | The Confirmation of Executors (Scotland) Act 1858 | In section 2 the words "next of kin". Section 18. |
| 24 & 25 Vict. c.86 | The Conjugal Rights (Scotland) Amendment Act 1861 | The whole Act except in relation to decrees of separation granted before the commencement of this Act. |
| 31 & 32 Vict. c.101 | The Titles to Land Consolidation (Scotland) Act 1868 | In section 117 the words from "provided that all" to the end. |
| 44 & 45 Vict. c.21 | The Married Women's Property (Scotland) Act 1881 | The whole Act. |
| 49 & 50 Vict. c.29 | The Crofters Holdings (Scotland) Act 1886 | In section 16 the words "by virtue of the Succession (Scotland) Act 1964" and "in accordance with Part I of the Succession (Scotland) Act 1964". |
| 63 & 64 Vict. c.55 | The Executors (Scotland) Act 1900 | In section 6 the words "in Scotland" where they first occur. |
| 1 & 2 Geo. 5 c.49 | The Small Landholders (Scotland) Act 1911 | In section 21 the words "by virtue of the Succession (Scotland) Act 1964". |
| 17 & 18 Geo. 5 c.35 | The Sheriff Courts and Legal Officers (Scotland) Act 1927 | Section 16. |
| 12, 13 & 14 Geo. 6 c.75 | The Agricultural Holdings (Scotland) Act 1949 | In section 20, in subsection (1) the words "by virtue of the Succession (Scotland) Act 1964" and in subsection (7) the words from "in accordance" to the end. |
| 3 & 4 Eliz.2 c.21 | The Crofters (Scotland) Act 1955 | In section 10, in subsection (5) the words "in accordance with Part I of the Succession (Scotland) Act 1964" and in subsection (7) the words "by virtue of the Succession (Scotland) Act 1964". In section 11(1) the words "in accordance with Part I of the Succession (Scotland) Act 1964". |
| 1964 c.41 | The Succession (Scotland) Act 1964 | Parts I and II. Section 14(2). Section 18(3). Sections 20 and 22. Part IV. Sections 30 and 31. Section 33(1). In section 37(1), the words from "or (as respects" to "Act 1978" and paragraph (e). |
| 1966 c.19 | The Law Reform (Miscellaneous Provisions) (Scotland) Act 1966 | Section 5. |

EXPLANATORY NOTES

Schedule 2

Parricide Act 1594

This repeal implements Recommendation 34(d). New statutory provisions relating to forfeiture for unlawful killing are in Clause 19.

Confirmation of Executors (Scotland) Act 1823

This section has been superseded by later legislation and practice. The repeal implements Recommendation 46.

Confirmation of Executors (Scotland) Act 1858

Section 18 empowers the Court of Session to regulate provision by Act of Sederunt. This power is now contained in the provisions of the Sheriff Courts (Scotland) Act 1971, as amended by paragraph 17 of Schedule 1 to the Bill.

Conjugal Rights (Scotland) Amendment Act 1861

The repeal of section 6 dealing with the effect of judicial separation on succession rights allows the whole Act to be repealed as it is the only operative section left. This repeal (with saving for pre-commencement decrees) implements Recommendation 39.

Titles to Land Consolidation (Scotland) Act 1868

This repeal follows from the abolition of legal rights and the fact that the new legal shares are calculated by reference to the deceased's whole net estate.

The Married Women's Property (Scotland) Act 1881

The only operative sections of this Act which remain in force deal with *jus relictii*. *Jus relictii* is abolished by Clause 5(6) of the Bill.

The Executors (Scotland) Act 1900

This repeal, together with Clause 21 of the Bill, implements Recommendation 47 and allows a Scottish court to confirm the executors of a Scottish domiciled person even though there is no estate situated in Scotland.

Sheriff Courts and Legal Officers (Scotland) Act 1927

Section 16 empowers the Court of Session to regulate procedure in the sheriff court and in the confirmation of executors. It has been superseded by the powers in the Sheriff Courts (Scotland) Act 1971 as amended by Paragraph 17 of Schedule 1 to the Bill.

Succession (Scotland) Act 1964

The repealed portions of the Act have either been replaced by new statutory provisions in the Bill or have been re-enacted.

Law Reform (Miscellaneous Provisions) (Scotland) Act 1966

See notes on Paragraphs 19 and 20 of Schedule 1.

Succession (Scotland) Bill

Sch. 2

| <i>Chapter</i> | <i>Short title</i> | <i>Extent of Repeals</i> |
|----------------|---|---|
| 1968 c.70 | The Law Reform (Miscellaneous Provisions) (Scotland) Act 1968 | Section 7. |
| 1973 c.25 | The Succession (Scotland) Act 1973 | The whole Act. |
| 1976 c.21 | The Crofting Reform (Scotland) Act 1976 | In section 21(3) the words "by virtue of the Succession (Scotland) Act 1964". |
| 1978 c.28 | The Adoption (Scotland) Act 1978 | Section 44. |
| 1980 c.55 | The Law Reform (Miscellaneous Provisions) (Scotland) Act 1980 | Section 5. |
| 1982 c.34 | The Forfeiture Act 1982 | Section 2. In section 5 the words "made under section 2 or". |
| 1985 c.37 | The Family Law (Scotland) Act 1985 | In section 1(4) the words from "nor any" to the end. |

EXPLANATORY NOTES

Law Reform (Miscellaneous Provisions) (Scotland) Act 1968

This provision has been replaced by a more general provision, see notes on Paragraph 7 of Schedule 1.

Succession (Scotland) Act 1973

This Act empowers the Secretary of State to alter the prescribed sums in relation to prior rights. The repeal is consequential upon the abolition of prior rights.

Adoption (Scotland) Act 1978

Section 44 provides that nothing in section 39 (status conferred by adoption) affects succession rights. Section 44 is repealed following relocation of the succession provisions from the Succession (Scotland) Act 1964 to the 1978 Act, see Paragraphs 19 and 20 of Schedule 1 to the Bill.

Law Reform (Miscellaneous Provisions) (Scotland) Act 1980

Section 5 provides that a surviving spouse who takes the whole intestate estate by virtue of prior rights need not find caution on being appointed executor-dative. This is incorporated in the new provision set out in Paragraph 1 of Schedule 1 to the Bill.

The Forfeiture Act 1982

Section 2 providing relief from forfeiture has been replaced by Clause 20 of the Bill.

Family Law (Scotland) Act 1985

The words in section 1(4) preserved aliment *ex jure representationis*. This is abolished by Clause 27 of the Bill.

Appendix B

List of those who submitted written comments on the memoranda or assisted with comments in the course of preparation of the report.

Building Societies Association
Capital Taxes Office
HM Commissary Office
Committee of Scottish Clearing Bankers
Mr Bruce Craig, Law Student, Aberdeen University
Dr Elizabeth Crawford, Glasgow University
Faculty of Advocates
*Federation of Business and Professional Women (Scottish Division)
Forensic Science Society
Professor W M Gordon, Glasgow University
Mr George Gretton, Edinburgh University
The Very Reverend Dr Andrew Herron
Law Society of Scotland
Dr Robert Leslie, Edinburgh University
Mr Hugh Macdonald, Advocate
Professor M C Meston, Aberdeen University
*Mothers' Union
The Rt Hon Lord Murray PC
National Farmers' Union of Scotland
Queen's and Lord Treasurer's Remembrancer
Regional Sheriff Clerks
Registers of Scotland
Mr Colin Reid, Aberdeen University
Mr P F Roper, Solicitor, Galashiels
Royal Faculty of Procurators in Glasgow
Ms Eilidh Scobbie, Aberdeen University
Scottish Landowners' Federation
Scottish Law Agents Society
Scottish Society for the Mentally Handicapped
Scottish Record Office
Mr David Sheldon, Law Student, Aberdeen University
Sheriffs' Association
The Sheriffs Principal
Society of Writers to HM Signet
Professor D M Walker, Glasgow University

*Comments submitted on pamphlet.